



Original instructions

TRANSPORT PLATFORM / MATERIAL HOIST

**BETA MAX**

**MC1600TP/M V**

**BY:**



**USE AND MAINTENANCE  
INSTRUCTION MANUAL**

Rev. 2.1 - 2025

SERIAL NUMBER: \_\_\_\_\_

PO Box 2750  
Melbourne, FL 32902  
PH: 800.233.5112 --- Fax 321.768.9517  
[www.betamaxhoist.com](http://www.betamaxhoist.com)





**BEFORE OPERATING, INSTALLATION, OR  
CARRYING OUT MAINTENANCE ON THE UNIT, IT IS  
IMPORTANT TO READ AND UNDERSTAND THE  
INFORMATION IN THIS MANUAL.**

**ATTENTION:**

The machine must not be used when the instruction manual is missing or not readily available for consultation. A copy of this manual must always be at hand and available to the operators. Improper use of the machine may cause great danger to people or damage other people's property.

**This manual is to be used only if the serial or model shown in the manual corresponds with the identification information shown on the machine. If they do not correspond, contact your BETA MAX retailer or agent.**



Owner: \_\_\_\_\_

Company name: \_\_\_\_\_

Address: \_\_\_\_\_

# USE AND MAINTENANCE INSTRUCTION MANUAL

Brand - Manufacturer: BETA MAX  
Type: MAX CLIMBER  
Model: MC1600TP/M V

		<u>Date</u>	<u>Signature</u>
Written By:	Beta Max	09-01-25	
Approval By:	Beta Max	11-13-25	

Descriptions and photos are only to be considered as pure illustrations. They may or may not be exact representation due to updated and revised changes made to the product.

According to continuous technological innovations, Beta Max, Inc. reserves the right to make any modifications with the intention of improving the product without notice.

All rights reserved.

**Copyright © 2025 BETA MAX, Inc.**

**Reproduction of this document by any means, in whole or in part, is prohibited without the authorization of BETA MAX, Inc.**



---

---

## TABLE OF CONTENTS:

TABLE OF CONTENTS:	i
<b>1 INTRODUCTION</b>	1-2
1.1 USE AND MAINTENANCE INSTRUCTION MANUAL	1-2
1.1.1 The importance of the manual	1-2
1.1.2 Conserving the manual	1-2
1.1.3 Consulting the manual	1-2
1.2 PURPOSE OF THE USE AND MAINTENANCE INSTRUCTION MANUAL	1-4
1.3 UPDATES OF THE MANUAL	1-6
1.4 DEFINITIONS	1-6
1.5 PREREQUISITES FOR THE MACHINE USER	1-7
1.5.1 Use and maintenance training	1-7
1.5.2 The user's responsibility	1-7
1.5.3 Training on the model of machine	1-7
1.6 PREREQUISITES FOR THE ASSIGNED OPERATOR	1-8
1.6.1 Preparatory information	1-8
1.6.2 The operator's training	1-8
<b>2 GENERAL INFORMATION</b>	2-1
2.1 IDENTIFICATION DATA OF THE MANUFACTURER AND THE MACHINE	2-1
2.2 MACHINE IDENTIFICATION PLATE	2-1
2.3 IDENTIFICATION SIGN	2-2
<b>3 MACHINE INFORMATION</b>	3-1
3.1 PREFACE	3-1
3.2 GENERAL DESCRIPTION	3-1
3.3 MACHINE LAYOUT	3-3
3.4 DESCRIPTION OF THE MACHINE	3-4
3.4.1 Base unit	3-6
3.4.2 Base enclosure unit	3-7
3.4.3 Vertical mast unit	3-8



---

3.4.4	Loading unit .....	3-9
3.4.5	Lifting unit .....	3-10
3.4.6	Floor landing unit .....	3-11
3.4.7	Electric cable guide unit .....	3-12
3.4.8	Electrical equipment.....	3-13
3.4.9	Electrical settings .....	3-13
3.4.10	Control Keyboard .....	3-16
3.4.11	Centrifugal Safety Brake Unit.....	3-17
3.4.12	Wall anchors unit .....	3-19
3.4.13	Platform for anchors mounting unit (erection platform).....	3-20
3.4.14	Accessories.....	3-21
3.5	TECHNICAL SPECIFICATIONS OF THE MACHINE .....	3-23
3.5.1	General data .....	3-23
3.5.2	Electrical specifications of the machine .....	3-23
3.5.3	Electrical Specifications of the Machine .....	3-23
3.5.4	Manufacturing Characteristics of the Electric Motors.....	3-23
3.5.5	Technical Specifications of Electric motors .....	3-23
3.5.6	Dimensions and capacities.....	3-24
3.5.7	Dimensions and weights .....	3-24
3.5.8	Loads/load capacity .....	3-25
3.5.9	Safety equipment .....	3-27
3.5.10	Recommended tightening torques.....	3-27
3.6	INTENDED USE .....	3-28
3.7	NORMAL CONDITIONS OF STORAGE .....	3-28
3.8	STORAGE CONDITIONS WITH TEMPERATURES REACHING A MINIMUM OF -4°F .....	3-28
3.9	STORAGE CONDITIONS WITH TEMPERATURES LOWER THAN -4°F .....	3-29
3.10	AMBIENT WORKING CONDITIONS.....	3-29



---

<b>4</b>	<b>WALL ANCHORS</b> .....	4-1
4.1	PREAMBLE .....	4-1
4.2	WALL ANCHORS .....	4-3
4.2.1	Distance between the anchors .....	4-4
4.2.2	The structure used for anchoring the machine .....	4-4
4.2.3	Allowed height of the topmost part above the last anchor.....	4-4
4.2.4	Mounting conditions for a free-standing mast.....	4-5
4.2.5	Conditions for anchoring the mast.....	4-6
4.2.6	Forces onto the wall anchor system .....	4-7
4.2.7	Type of anchor systems .....	4-12
4.2.8	Working conditions with a free-standing mast (not anchored) .....	4-13
4.2.9	Information for the commissioning of the mast .....	4-13
4.2.10	Mast anchor frame assembly .....	4-15
4.2.11	Opposite mounting of wall ties .....	4-18
<b>5</b>	<b>HANDLING AND TRANSPORTATION</b> .....	5-1
5.1	INTRODUCTION AND PRELIMINARY OPERATIONS .....	5-1
5.2	TRANSPORTATION .....	5-2
5.3	HANDLING .....	5-3
5.4	LOADING AND UNLOADING .....	5-5
<b>6</b>	<b>INSTALLATION</b> .....	6-1
6.1	INTRODUCTION.....	6-1
6.2	INSTALLATION DATA SHEET .....	6-2
6.3	INSTALLATION PROCEDURE.....	6-3
6.4	TEST AND VERIFICATION DATA SHEET OF THE MACHINE'S COMPONENTS.....	6-4
6.5	FOUNDATION FOR POSITIONING THE MACHINE .....	6-5
6.5.1	Concrete slab resting on the ground .....	6-7
6.5.2	Concrete slab at the same level of the ground .....	6-7
6.5.3	Concrete slab below ground level .....	6-7
6.5.4	Boarding structure support for surfaces which are not so solid.....	6-8



---

6.6	DISTANCE OF THE MACHINE FROM OBSTACLES .....	6-9
6.6.1	Shearing risk for people moving on structures adjacent to the machine .....	6-9
6.6.2	Shearing risk for people transported on the machine .....	6-10
6.6.3	Shearing risk for people moving on structures adjacent to the machine .....	6-11
6.7	MOUNTING INSTRUCTIONS .....	6-12
6.8	MOUNTING THE PRE-ASSEMBLED MACHINE .....	6-13
6.8.1	Positioning the machine on the ground .....	6-14
6.8.2	Preparing the machine’s functionality before connecting the power supply .....	6-16
6.8.3	Connecting the power supply .....	6-17
6.8.4	The first handling process of the machine .....	6-18
6.9	MOUNTING THE MAST AND THE FIRST WALL ANCHOR .....	6-21
6.10	MOUNTING THE ANCHORS .....	6-24
6.11	MOUNTING THE ELECTRIC CABLE GUIDE .....	6-28
6.12	MOUNTING SUBSEQUENT MASTS .....	6-29
6.13	MOUNTING OF LANDING AND SLOWDOWN PADS .....	6-30
6.13.1	Landing pads .....	6-30
6.13.2	3M Terminal stop pad at 10 ft.....	6-31
6.13.3	Floor level braking pads .....	6-32
6.13.4	Mast Presence Device .....	6-33
6.14	MOUNTING THE DOORS .....	6-34
6.14.1	Mounting the hinged doors.....	6-34
<b>7</b>	<b>COMMAND AND CONTROL DEVICES.....</b>	<b>7-1</b>
7.1	GENERAL INFORMATION ON COMMAND DEVICES.....	7-1
7.2	COMMANDS ON THE BASE CONTROL PANEL .....	7-2
7.2.1	Main switch/disconnect .....	7-3
7.2.2	Signal light PRESENCE PHASE 1 .....	7-3
7.2.3	Signal light PRESENCE PHASE 2 .....	7-3
7.2.4	Signal light PRESENCE PHASE 3 .....	7-3
7.2.5	UP pushbutton .....	7-3



---

7.2.6	DOWN pushbutton .....	7-3
7.2.7	START/FLOOR BYPASS pushbutton .....	7-3
7.2.8	Machine mode key selector (MATERIAL/TRANSPORT PLATFORM).....	7-3
7.2.9	EMERGENCY pushbutton .....	7-4
7.2.10	Plug for Trailing Cable.....	7-4
7.2.11	Plug for Ground Enclosure Gate .....	7-4
7.2.12	Plug for Floor Call Boxes.....	7-4
7.2.13	3-METER LASTS pushbutton .....	7-4
7.3	COMMANDS ON THE ONBOARD CONTROL PANEL.....	7-5
7.3.1	Main switch .....	7-6
7.3.2	Signal light NORMAL LOAD.....	7-6
7.3.3	Display Touchscreen.....	7-6
7.3.4	Automatic Greaser .....	7-6
7.3.5	Machine mode key selector (MATERIAL/TRANSPORT PLATFORM).....	7-6
7.3.6	OVERTRAVEL BYPASS key selector .....	7-6
7.3.7	Numeric keypad .....	7-6
7.3.8	START pushbutton.....	7-7
7.3.9	Electric panel lock .....	7-7
7.3.10	3-M push button .....	7-7
7.3.11	EMERGENCY pushbutton .....	7-7
7.3.12	Signal light FULL LOAD .....	7-7
7.3.13	Signal light OVERLOAD.....	7-7
7.3.14	ACOUSTIC ADVISOR .....	7-7
7.3.15	Plug for TRAILING CABLE.....	7-7
7.4	COMMANDS ON GROUND CONTROL PENDANT (if equipped).....	7-8
7.4.1	UP push button .....	7-8



---

7.4.2	DOWN push button .....	7-8
7.4.3	ENGAGE/FLOOR BYPASS push button.....	7-8
7.4.4	EMERGENCY push button .....	7-8
7.5	COMMANDS ON FLOOR CALL BOXES .....	7-9
7.5.1	UP push button .....	7-9
7.5.2	DOWN push button .....	7-9
7.5.3	ENGAGE/FLOOR BYPASS push button.....	7-9
7.5.4	EMERGENCY push button .....	7-9
7.5.5	Plug for floor call box.....	7-9
7.6	COMMANDS ON THE DROP TEST PENDANT .....	7-10
7.6.1	UP push button .....	7-10
7.6.2	TEST push button .....	7-10
7.6.3	EMERGENCY pushbutton .....	7-11
7.7	OVERLOAD DETECTION DEVICE.....	7-11
<b>8</b>	<b>SAFETY REGULATIONS .....</b>	<b>8-1</b>
8.1	DESCRIPTION OF THE MACHINE'S SAFETY SYSTEMS.....	8-1
8.2	MOVABLE GUARDS .....	8-2
8.2.1	Electrically controlled and mechanical interlocking movable guards.....	8-2
8.2.2	Electrically controlled movable guards .....	8-3
8.2.3	Movable guards which lock with a key or tool.....	8-4
8.3	FIXED GUARDS .....	8-5
8.4	SAFETY EQUIPMENT .....	8-6
8.4.1	Mechanical equipment .....	8-6
8.4.2	Electro-mechanical equipment.....	8-6
8.4.3	Electrical equipment.....	8-7
8.4.4	Overload control device (if equipped).....	8-8
8.5	LIST OF PLATES FOUND ON THE MACHINE.....	8-9
8.5.1	Signs onboard the machine.....	8-10



---

8.6	FUNDAMENTAL SAFETY REGULATIONS .....	8-11
8.6.1	General safety regulations .....	8-11
8.6.2	Local safety regulations .....	8-11
8.6.3	Environmental conditions .....	8-11
8.6.4	Pre-installation requirements.....	8-12
8.6.5	Individual protection gear regulations .....	8-12
8.6.6	Regulations pertaining to electricity .....	8-12
8.6.7	Regulations pertaining to spare parts .....	8-12
8.7	REGULATIONS PERTAINING TO MAXIMUM LOADS .....	8-13
8.8	RESIDUAL RISKS .....	8-16
8.8.1	Risks arising from operating with configurations not provided for by the manufacturer .....	8-16
8.8.2	Risks arising from an incorrect positioning of the machine .....	8-17
8.8.3	Shearing risk deriving from machine proximity to obstacles .....	8-17
8.8.4	Risks arising from transporting the machine.....	8-18
8.8.5	Risks arising from incorrect assembly on the ground .....	8-19
8.8.6	Risks arising from incorrect overground assembly .....	8-20
8.8.7	Risks arising from functional verification of the machine .....	8-21
8.8.8	Risks arising from the machine’s normal operation .....	8-22
8.8.9	Risks arising from descending the machine manually .....	8-23
8.8.10	Risks arising from handling the machine in the construction site .....	8-24
8.8.11	Risks arising from disassembling the machine .....	8-24
<b>9</b>	<b>PREPARATION FOR MACHINE USE .....</b>	<b>9-1</b>
9.1	SAFETY REQUIREMENTS BEFORE HANDLING THE MACHINE.....	9-1
9.2	SAFETY REQUIREMENTS DURING MACHINE OPERATION.....	9-2
9.3	SAFETY VERIFICATION INSTRUCTIONS.....	9-2
9.3.1	General verification of the machine .....	9-2
9.3.2	Electrical verification of the machine .....	9-3



---

9.3.3	Verification of the machine’s motion .....	9-3
9.4	MANUAL DESCENT PROCEDURE.....	9-4
9.4.1	General regulations to descend manually but safely .....	9-6
9.5	OPERATING THE MACHINE.....	9-7
9.6	OPENING OF GATES FOR EGRESS TO BUILDING .....	9-7
9.7	SHUTTING DOWN THE MACHINE AT THE END OF A WORK SHIFT .....	9-8
9.8	SHUTTING DOWN THE MACHINE FOR LONG PERIODS .....	9-8
<b>10</b>	<b>TROUBLESHOOTING</b> .....	<b>10-1</b>
10.1	THE MACHINE DOES NOT START .....	10-1
10.2	THE MACHINE STOPS ABRUPTLY.....	10-1
10.3	ELECTRIC MOTORS TROUBLESHOOTING .....	10-2
<b>11</b>	<b>MAINTENANCE AND REPAIR</b> .....	<b>11-1</b>
11.1	GENERAL INSTRUCTIONS .....	11-1
11.2	MAINTENANCE SCHEDULE.....	11-2
11.2.1	General maintenance (Daily).....	11-3
11.2.2	General maintenance (40 hours).....	11-4
11.2.3	General maintenance (125 hours).....	11-5
11.2.4	General maintenance (500 hours).....	11-5
11.3	FUNDAMENTAL MAINTENANCE OPERATIONS .....	11-6
11.3.1	Verification of the lifting unit’s pinions.....	11-7
11.3.2	Verification of the lifting unit’s drive system .....	11-8
11.3.3	Wear and tear verification of the lifting unit’s drive wheels.....	11-9
11.3.4	Inspection of the rack and the vertical components .....	11-9
11.3.5	Verification and adjustment of the air gap of the motor brakes .....	11-10
11.3.6	Servicing the gear motors .....	11-11
11.3.7	Lubricating the machine .....	11-13
11.3.8	Calibration of the OVERWEIGHT SENSOR system.....	11-14
11.4	TESTING THE SAFETY BRAKE DEVICE .....	11-15
11.4.1	Resetting the safety brake device .....	11-16



---

11.5	ELECTRICAL SYSTEM MAINTENANCE.....	11-18
11.5.1	Maintenance of the electrical system rectifier.....	11-18
11.6	TECHNICAL SUPPORT.....	11-19
<b>12</b>	<b>ADDITIONAL INSTRUCTIONS</b> .....	<b>12-1</b>
12.1	MACHINE NOISE LEVEL .....	12-1
12.2	INDICATIONS TO DECOMMISSION THE MACHINE.....	12-1
<b>13</b>	<b>WARRANTY</b> .....	<b>13-1</b>
13.1	WARRANTY .....	13-1
	Appendix A.....	A
	Appendix B.....	B
	Appendix C .....	C
	Appendix D .....	D
	Appendix E.....	E
	Appendix F.....	F



**This page has been left blank for formatting purposes**

# CHAPTER 1: INTRODUCTION

Record of modifications

Revision	Executor	Date	Description of modification

## 1 INTRODUCTION

### 1.1 USE AND MAINTENANCE INSTRUCTION MANUAL

#### 1.1.1 The importance of the manual

We would like to thank you for choosing a machine from the MAX CLIMBER range, manufactured by BETA MAX. We would like to remind you that this manual is an integral part of the machine itself; therefore, you must look after the manual throughout the operational life of the product and hand it over to any other user or subsequent owner, who has the duty to ask for it and the right to obtain it.

#### 1.1.2 Conserving the manual

The manual must be carefully kept away from humidity and heat, and it is to be used in such a way so as not to damage the content or alter the format.

For no reason, do not remove, tear, or rewrite any parts of the manual.

#### 1.1.3 Consulting the manual

The manual is essentially divided into the following:

- identification page or “OVERVIEW” showing the version of the manual and the date of issue
- index by subject
- instructions and/or notes on the product
- enclosures

This manual contains warnings that will draw the operator’s attention to a procedure or function.

**NOTE:** these are warnings to guide and optimize the operator’s actions or to better highlight characteristics of the machine

**ATTENTION:** these are very important warnings that specify which actions are to be done, not to be done, or precautions which are to be taken before operating the machine in order not to cause damage to it

**DANGER:** these are extremely important warnings that specify which actions are to be done, not to be done, or precautions which are to be taken before operating the machine so as to not harm people

**NOTE:**

The manual must be carefully read and understood by the various operators, before carrying out their duties and responsibilities when handling the machine.

The instruction manual for the use and maintenance of the machine is intended for:

- the machine user;
- the owner;
- the site manager where the machine is installed and used;
- assigned staff for assembling and disassembling the machine;
- the maintenance staff;
- the operators;
- the people in charge of its displacement.

It is mandatory for the instruction manual to be read before handling, installing, using, carrying out any maintenance or shutting down the machine; therefore, it is necessary to keep this manual intact over time by conserving it in a safe place and making copies for frequent use.

Handling, installing, using, carrying out maintenance or shutting down the machine may constitute a danger if not carried out per the requirements of this manual or without due caution and attention, which such actions require.

## 1.2 PURPOSE OF THE USE AND MAINTENANCE INSTRUCTION MANUAL

This manual provides the necessary information for the proper use of the machine, allowing you to carry out the following operations:

- INSTALLATION
- OPERATION
- MAINTENANCE
- SHUTTING DOWN

### **NOTE:**

If the warnings and suggestions presented in this manual, regarding the above-mentioned operations, are not complied with, BETA MAX cannot be held responsible for the safety, reliability, and performance of the machine.

### **NOTE:**

Failure to meet the requirements stipulated in this manual relieves the Manufacturer from responsibility, or any incidents pertaining to such negligence.

Moreover, it is to be noted that in any of the instances listed below:

- improper use of the machine
- untrained staff using the machine
- total or partial non-compliance with the instructions contained in this manual
- non-compliance with national regulatory specifications pertaining to safety at work
- installed incorrectly or with configurations that are not permitted
- defects in power supply
- non-compliance with the instructions concerning the scheduled maintenance operations
- unauthorized modifications or interventions carried out on the machine
- use of spare parts other than those provided by BETA MAX

BETA MAX will not be held liable for risks caused because of non-compliance with such requirements. The manual cannot be used as a reference if the intention is to carry out modifications that affect the machine's configuration. However, the Company retains the exclusive responsibility pertaining to any manufacturing defects.

**NOTE:**

The correct use of this machine entails the precise knowledge of these usage instructions and all the risks related to improper use of the same machine.

**DANGER:**

The purchaser or the user of the machine bears full responsibility for shutting down the security/safety systems or all that provided by the Manufacturer for the safety of the users and operators.

### 1.3 UPDATES OF THE MANUAL

This instruction manual reflects the condition of the machine as at the time the machine was marketed and sold; it cannot be considered inadequate solely because it has been subsequently updated based on newly acquired knowledge. BETA MAX reserves the right to upgrade its products and manuals, in line with its policy to continuously improve product quality, with no obligation of upgrading previous productions and manuals, except in particular cases.

The edition of an updated version of the use and maintenance instruction manual will not oblige the manufacturer to update this manual, except in the instance of new regulations being introduced, which narrow down the danger posed by the machine during its operation, or upgraded features are installed. In these instances, BETA MAX undertakes to provide the Client with a new version of the manual.

### 1.4 DEFINITIONS

The following definitions will be found in the descriptions within this manual:

- USER.
  - OPERATOR.
  - MACHINE.
- “USER” refers to the person who, due to his qualification, is appointed as site manager where the machine is installed or the person who is directly responsible for the security of the place where the same machine is installed.
- “OPERATOR” refers to the person who, due to his qualification, is designated to install, operate, use, carry out maintenance works, clean, repair or transport the machine.
- “MACHINE” refers to the Transport Platform/Material Hoist with a rack drive system mounted onto masts, with the brand name BETA MAX MC1600TP/M model, in all its possible conformations and configurations. From this point onwards in this instruction manual, when reference is made to the Transport Platform/Material Hoist MC1600TP/M model, solely “MACHINE” will appear.

#### **ATTENTION:**

The operator assigned to work on the machine must be trained on how to use the machine, the safety devices and the installed equipment and accessories correctly. The operator must always wear the specific, personal protection equipment and clothing which is appropriate from a safety point of view and adequate for the type of work that is to be carried out (gloves, ear plugs, safety shoes, safety harnesses, hard hat, goggles, etc.).

## 1.5 PREREQUISITES FOR THE MACHINE USER

The information contained in this manual must be supported by the work being carried out well and applying firm principles of safety, training, inspection, assembly, maintenance, implementation, and operation, consistent with all the data available, pertaining to the parameters of usage required and consideration of the surroundings and environment in question. Given that the user has direct control over the machine's operation and its functions, it is his responsibility and that of his staff to ensure that these comply with the necessary safety requirements. Any decisions regarding the use and operation of the machine must always be taken after having considered that the same machine can carry persons as well as material. The safety of the people who work on the machine or nearby, depends on such decisions.

### 1.5.1 Use and maintenance training

The user must train his maintenance staff on how to inspect, assemble and carry out maintenance on the machine in accordance with the sections in this manual pertaining to the Manufacturer's instructions and recommendations.

### 1.5.2 The user's responsibility

Whenever a user assigns or authorizes an individual to operate the machine, it is his responsibility to ensure that the individual in question has been trained in accordance with the requirements stipulated in this manual under the sections pertaining to the installation and operation, together with the working knowledge imparted by the user himself.

### 1.5.3 Training on the model of machine

The user is responsible for training the operator on how to use the model of machine he works on. Such training must take place in an area that is free from any obstruction, under the direction of a qualified person and for a period which is long enough to ensure that the person being prepared is competent to use the machine.

Only members of staff who are well-prepared and who are authorized must be allowed to use the machine.

Before allowing an operator to use the machine, the user must ensure that the operator:

- has been well-prepared, by a qualified person, on the purposes and functions of each control
- has read and understood the instructions in this manual and the safety regulations passed on by the user
- has understood all the warnings and instructions provided for the proper and safe operation of the machine, by reading or by means of the explanations given by a qualified person
- has understood that the machine is to be used in accordance with the applications defined by the Manufacturer

## 1.6 PREREQUISITES FOR THE ASSIGNED OPERATOR

The information contained in this instruction manual must be supported by sound judgment, appropriate safety checks and caution in assessing every situation.

Since the operator has direct control of the machine, it is his responsibility to comply with the safety requirements in question. The operator must take decisions on the use and operation of the machine, bearing in mind that his personal safety, just like that of the staff members working on the same machine (only during installation and disassembly) and in the vicinity, depends upon his decisions.

### 1.6.1 Preparatory information

The operator must be aware that this instruction manual is found on the machine and must know where it is placed exactly. The operator must be confident in referring to the manual of the machine and must consult it whenever he is faced with doubts or questions regarding the safe and proper use of the machine itself.

### 1.6.2 The operator's training

The operator must be trained either on the same model of machine or on a model that has characteristics of operation and control that correspond with the machine that is to be used. The operator must operate the machine in an area that is free from any obstruction, under the direction of a qualified person and for a period which is long enough to ensure that the person being prepared is competent to use the machine. Only members of staff who are well-prepared and who are authorized must be allowed to use the machine.

Before being given authorization to use the machine, the operator must have:

- been trained by a qualified person, and understands the purpose and function of each control
- read and understands the instructions for the proper use of the machine and the safety regulations, or been trained on the contents of the instruction manual and the above-mentioned regulations by a qualified person
- understands all the warnings and instructions found on plates and tables on the machine, after having read this instruction manual or by means of the explanations given by a qualified person



## CHAPTER 2: GENERAL INFORMATION

Record of modifications

Revision	Executor	Date	Description of modification

## 2 GENERAL INFORMATION

### 2.1 IDENTIFICATION DATA OF THE MANUFACTURER AND THE MACHINE

Manufacturer: Electroelsa s.r.l.  
 Loc. Il Piano (53031)  
 Casole d'Elsa (Siena) – ITALIA  
[www.electroelsa.com/en](http://www.electroelsa.com/en)

Distributor: Beta Max, Inc.  
 P.O. Box 2750  
 Melbourne, FL 32902-2750  
[www.betamaxhoist.com](http://www.betamaxhoist.com)  
[info@betamaxhoist.com](mailto:info@betamaxhoist.com)

Type: TRANSPORT PLATFORM/MATERIAL HOIST

Model:  MC1600TP/M V

Serial Number: \_\_\_\_\_

Year of Manufacture: 20 \_\_\_\_\_

### 2.2 MACHINE IDENTIFICATION PLATE

The identification plate of the machine is placed on the inside of the loading unit. The plate allows clear identification of the type of machine, the manufacturer, the serial number, and the fundamental characteristics of the machine.

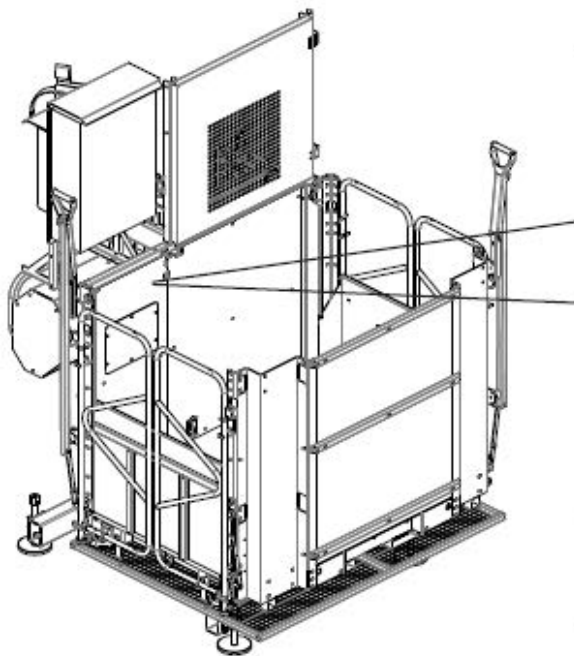

		P.O. Box 2750 Melbourne, FL 32902-2750 TF 888-283-8112 PH 321-727-8737 FX 321-768-8517	
MAX CLIMBER			
Model # <input style="width: 100%;" type="text"/>		Year of Manufacture <input style="width: 100%;" type="text"/>	
Serial # <input style="width: 100%;" type="text"/>	Max Lifting Height (ft) <input style="width: 100%;" type="text"/>	Rated Work Load (lbs) <input style="width: 100%;" type="text"/>	Base Unit Weight (lbs) <input style="width: 100%;" type="text"/>
Voltage (V) <input style="width: 100%;" type="text"/>	Lifting Speed (ft/min) <input style="width: 100%;" type="text"/>	Amperage (A) <input style="width: 100%;" type="text"/>	Max Wind Speed (Operation) (MPH) <input style="width: 100%;" type="text"/>
Phase <input style="width: 100%;" type="text"/>	Max Wind Speed (Gusts) (MPH) <input style="width: 100%;" type="text"/>	Frequency (Hz) <input style="width: 100%;" type="text"/>	
This unit is manufactured to comply with ANSI Standard <input style="width: 100%;" type="text"/>			
10-682			

Figure 2.1

## 2.3 IDENTIFICATION SIGN

The machine is identified by means of the identification sign MC1600TP/M V where:

- the prefix “MC” stands for Max Climber, that refers to a Rack and Pinion Transport Platform or Hoist
- the suffix “TP” stands for TRANSPORT PLATFORM (machine used to transport persons and materials)
- the suffix “M” stands for MATERIAL HOIST (machine used to transport materials **ONLY**)
- the numerical suffix “1600” means that the rated load of the machine is 1600 lbs. **The machine is used to transport persons and materials governed by ANSI/SAIA A92.10 the maximum of 4 people and an additional 800 lbs. are allowed on board. When the machine is used as a MATERIAL HOIST governed by ANSI/ASSE A10.5 the maximum load of 1600 lbs. and “NO RIDERS ARE ALLOWED” on board**
- the suffix “V” stands for a variable frequency drive (VFD) control system

The MC1600TP/M V is a transport platform/material hoist with a vertical triangular supporting mast, designed to reach a maximum mast height of 400 feet.

Since the machine has been created with characteristics which are totally modular, whichever height of assembly is reached (up to the max. height of 400 ft) identical modules are to be used (masts, wall anchors etc.).

### NOTE:

Depending on the size of the structure or the work arrangement, BETA MAX machines may be equipped with various gear-motors for the lifting unit, and the mast section may be triangular or rectangular.

The descriptions provided further on, and the relative illustrations may show machines which have characteristics that are different from those of the machine referred to in this manual. This applies solely and exclusively to all the general descriptions, where reference is not made to fundamental details for understanding machine operation and more importantly, all descriptions of the machine's safety systems.



**This page has been left blank for formatting purposes**

## CHAPTER 3: MACHINE INFORMATION

Record of modifications

Revision	Executor	Date	Description of modification

## **3 MACHINE INFORMATION**

### **3.1 PREFACE**

The machine has been designed and manufactured in accordance with the highest standards of quality and safety. The manual provides instructions and recommendations to the operator and qualified assigned staff, for them to safely control all situations when the machine is used, allowing them to carry out the service and maintenance required on the product itself. This use and maintenance instruction manual must be available to the members of staff who work on the machine throughout its service life.

The designs shown are for illustration purposes only and do not necessarily represent the products on the market. These products must be used in accordance with applicable experience and safety regulations. The specifications of the products and parts shown in this manual are subject to change without giving prior notice.

### **3.2 GENERAL DESCRIPTION**

The machine is designed and constructed in accordance with the following laws (when and if applicable):

- ANSI/SIA A92.10 – American National Standard for Transport Platforms.
- ANSI/ASSE A10.5 – American National Standard: Safety Requirements for Material Hoists
- MACHINE DIRECTIVE 2006/42/CE, which modifies the European rule 95/16/CE relative to the hoists, turned into a legislative decree 27 January 2010, n. 17.
- DIRECTIVE (2000/14/CE) ENVIRONMENTAL ACUSTIC EMISSION of the machines and tools made to work on open air, turned into a legislative decree 4 September 2002, n. 262.UNI EN 1495: 2009 - Mast climbing platform.
- EN 12158-1: 2010 - BUILDERS HOIST FOR GOODS - Parts 1: Hoist with accessible platform.
- GUIDELINES for the construction sector: Transportation of persons and goods between defined floors in temporary construction sites; ISPESL; Ministry of Labor and Social Policies; Ministry of Productive Activities; ACAI; ANIMA; ANCE”.
- UNI EN 81-1: 2008 - Safety rules for manufacturing and erection of construction hoists - Part 1: Electric construction hoists.
- UNI EN 81-2: 2008 - Safety rules for manufacturing and erection of construction hoists - Part 2: Hydraulic construction hoists.
- UNI EN 81-3: 2008 - Safety rules for manufacturing and erection of construction hoists and material hoists - Part 3: Electric and hydraulic material hoists.
- UNI EN ISO 12100-1: 2005 - Machinery safety - Fundamental concepts, design general concepts - Part 1: Base terminology, methodology.
- UNI EN ISO 12100-2: 2005 - Machinery safety - Fundamental concepts, design general concepts
  - Part 2: Technical concepts.
- UNI EN ISO 13875: 2008 - Machinery safety - Safety distances preventing danger zones being reached by the upper and lower limbs.

- UNI EN 349: 2008 - Machinery safety - Minimum distances avoiding crushing parts of human body
- UNI EN ISO 13850: 2008 - Machinery safety - Emergency stop - Design concepts
- UNI EN 894-1: 2009 - Machinery safety - Ergonomic requirements for design of display and control actuators - Part 1: General principles for human interactions with information devices and commands.
- UNI EN 894-2: 2009 - Machinery safety - Ergonomic requirements to project information and command devices - Part 2: Information and command devices.
- UNI EN 894-3: 2009 - Machinery safety - Ergonomic requirements for information and command devices projection - Part 3: Command devices.
- UNI EN 953: 2009 - Machinery safety - Protection elements - General requests for design and construction of fixed and mobile safety guards.
- UNI EN ISO 13849-1: 2007 - Machinery safety - Command system parts relative to safety - Part 1: General concepts for design.
- UNI EN 982: 2009 - Machinery safety - Safety rules relating to systems and its components for oil-hydraulic and pneumatic transmissions - Oil-hydraulic.
- UNI EN 1037: 2008 - Machinery safety - Non expected start up prevention.
- UNI EN 1088: 2008 - Machinery safety - Interlock devices associated with safety guards - Design and selection concepts.
- CEI EN 60204-1: 1998 - Machinery safety - Electric devices of the machine - Part 1: General rules.
- CEI EN 60204-2: 1998 - Machinery safety - Electric devices of the machine - Part 2: Raising machines prescription.
- CEI EN 60529 - Protection degree of casings (Code IP).
- IEC EN 60947 - Low tension commutates - Electro-mechanic contactors and startups.
- ELECTROMAGNETIC COMPATIBILITY (2004/108/CE) turned into a legislative decree 6 November 2007 nr. 194.
- LOW VOLTAGE ELECTRICAL EQUIPMENT (73/23/CEE, 93/68/CEE) turned into law nr. 791 del 1991 e law Nr. 626 del 1996.
- EN 954-1: Machinery safety - Safety related parts of control systems - Part 1: General concepts for protection.
- ISO 3864: 1984 - Safety colors and safety signalization.
- UNI ISO 4302: 1998 - Raising devices - Wind's load.
- UNI ISO 4309: 2009 - Raising devices - Ropes - Care, maintenance, installation, check and waste.
- EN 50099-1: Machinery safety - Instruction concepts, marks and application - Part 1: Visual signals, aural and touch.
- UNI EN ISO 14121-1: 2007 - Machinery safety - Risk evaluation.

The following description explains in detail the appropriate use of the machine and presents the various components used in the same machine. For specific information about the operational procedures please refer to the contents found in the specific chapter, further on in this manual.

### 3.3 MACHINE LAYOUT

Figure 3.1 shows the MC1600TP/M V base unit.

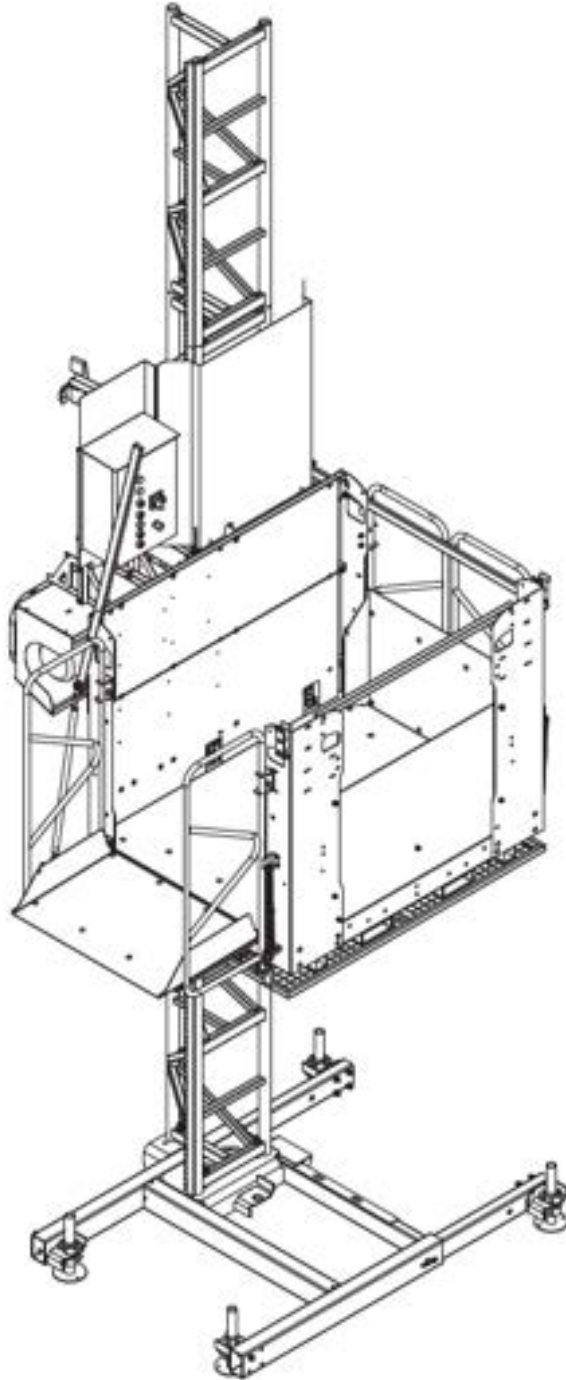

Figure 3.1

### 3.4 DESCRIPTION OF THE MACHINE

The main sections of the machine shown in figure 3.2 and listed in the legend below are then described in detail in the subsequent paragraphs.

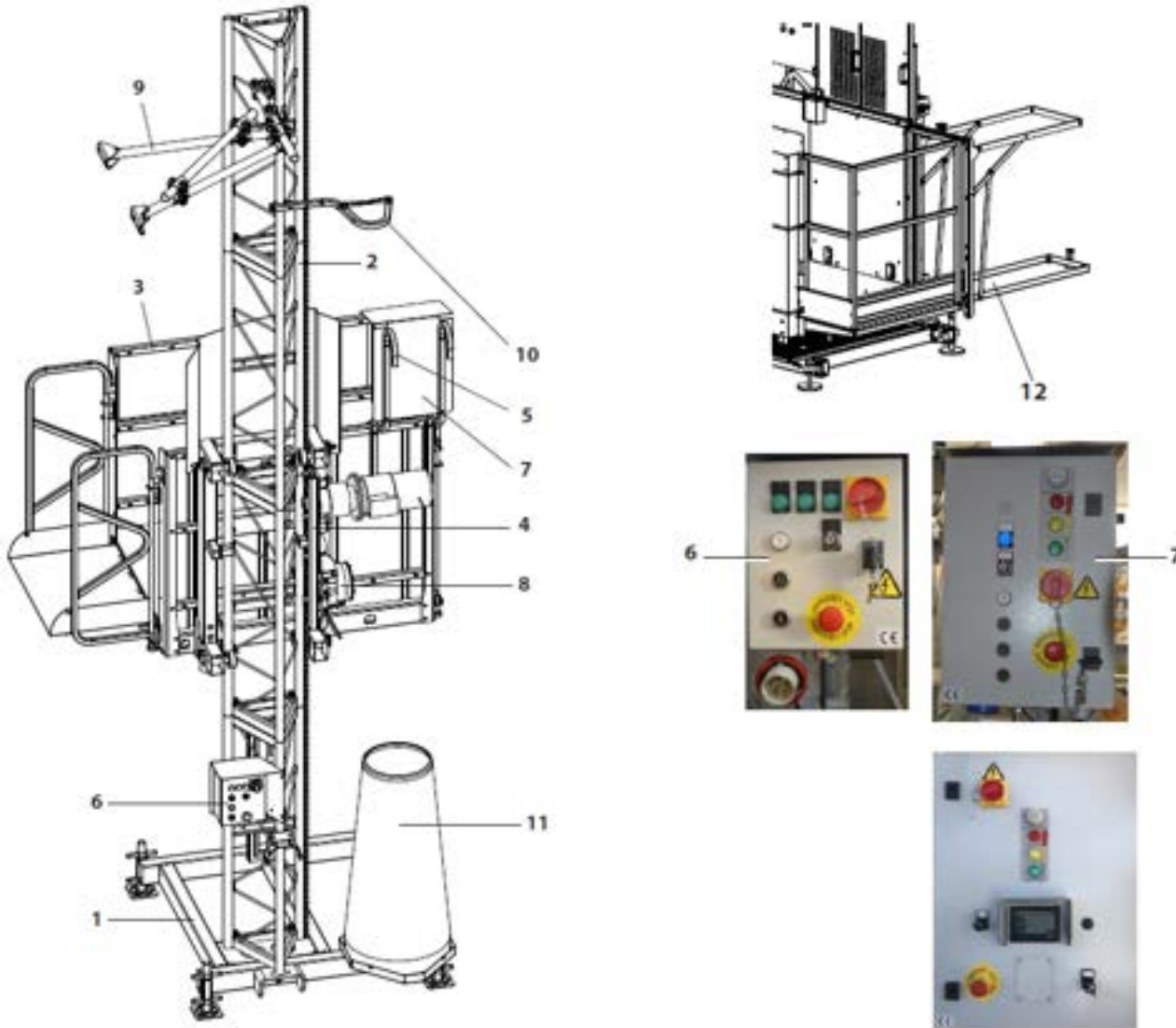

Figure 3.2

#### LEGEND

- |   |                         |    |                                 |
|---|-------------------------|----|---------------------------------|
| 1 | Base unit               | 7  | Onboard control panel           |
| 2 | Vertical mast unit      | 8  | Overspeed brake (safety brake)  |
| 3 | Loading Unit (Platform) | 9  | Wall anchor unit                |
| 4 | Lifting unit            | 10 | Trailing cable guide            |
| 5 | Trailing Cable Bracket  | 11 | Cable barrel                    |
| 6 | Base control panel      | 12 | Erection platform (if equipped) |



The machine consists of a base unit made of steel sections and acts as a support on the ground while sustaining the entire vertical part of the machine. The base unit is equipped with a leveling system to be leveled with the flooring and a vertical mast tower with triangular sections (side measure 15.75 in) on which the lifting unit travels and in turn supports the loading unit.

The loading unit is paneled with aluminum sheets and has dumping doors to give access to the material and personnel onto the landing platform.

The mast is made of modular elements which allow the machine to reach a maximum height of **400 ft.** The parts are easily and safely assembled by the personnel working from inside the cabin. The attachment of the vertical mast to the structure is secured by adequate anchor structures and an additional the erection platform is used for their assembly.

The loading unit is lifted by means of a gear motor with a self-braking electric motor that employs a rack that is solidly connected to the mast. The motor unit, powered by an electric cable gathered at the base of the machine in an appropriate container, is controlled by electric control panels onboard the machine and on ground level outside the base unit.

If the machine is equipped with a floor-level calling system, the electric power cable also includes conductors for the drive signal.

In instances of a power failure or a technical fault, the gear-motors are equipped with a manual brake release for the electric motor. This device allows the cabin to be lowered by gravity until adequate safety conditions are reached to carry out work on the machine.

The machine is equipped with an emergency progressive brake (safety brake), which is activated if the gear-motor malfunctions or in case of an excessive speed of descent.

Hereunder are the descriptions of all the machine's components; those supplied as standard as well as optional components which the client may opt for or may be specifically required due to legislation in some countries.

### 3.4.1 Base unit

The base unit (1) is the structural component which rests on the ground and supports the mast (2). It is made of structural steel sections connected by electric welding and screws. Other than supporting the mast, its function is that of spreading the machine's overall weight evenly on an extensive foundation area. To the basement are applied four leveling screw jacks (3) which, with the help of a level, allow putting the tower in perfect upright position even on sloping grounds. For machines reaching a working height higher than 65 ft, the base unit must be lowered to the ground and no longer supported by the leveling screw jacks. The electric cable container (not shown) aligns with the cable arm (gooseneck) located on the lifting unit.

If the machine is used without the mast being anchored, the base unit must be properly set into the foundation; for example, with anchor bolts or lag bolts sunken directly into the cement (for this operation, please refer to the relevant paragraph in this manual).

The base unit is protected against corrosion by means of hot galvanization.

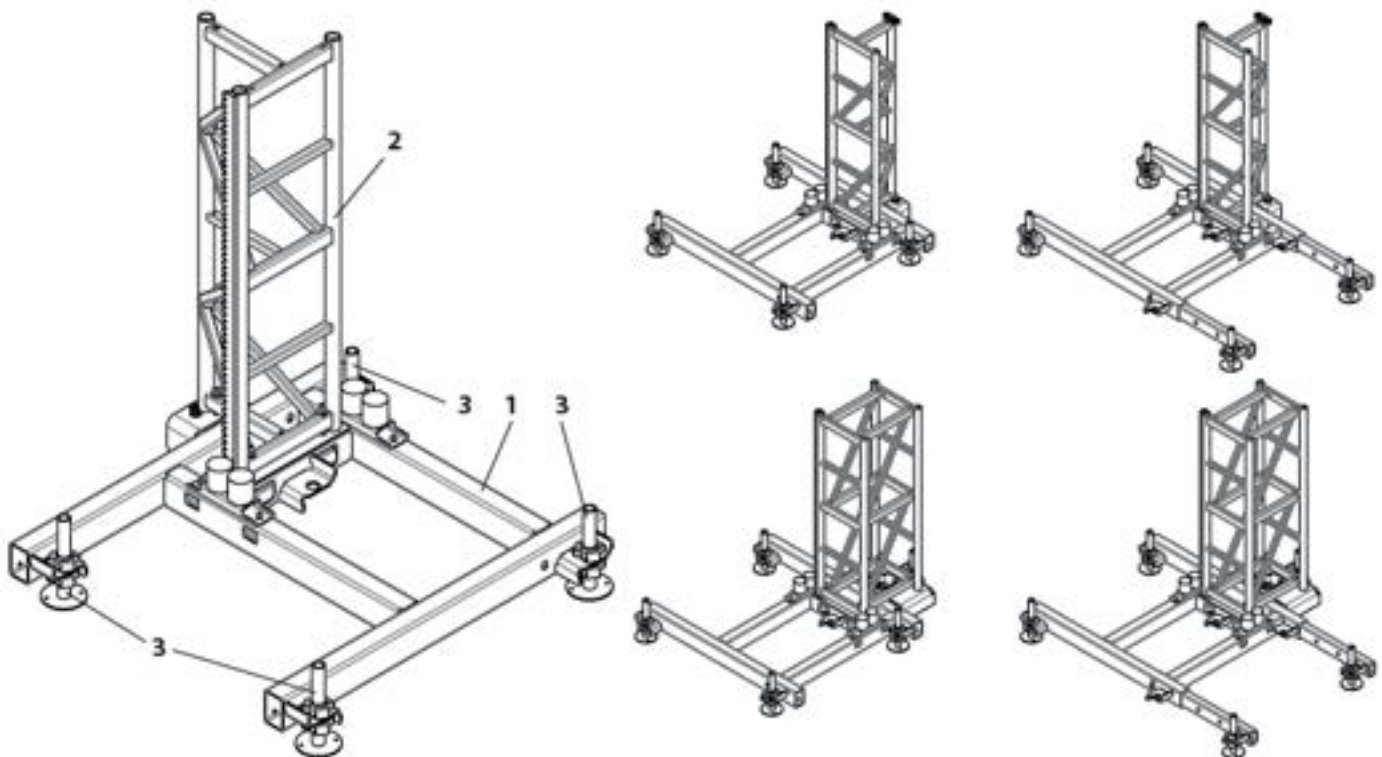

Figure 3.3

### 3.4.2 Base enclosure unit

The function of the base enclosure (1) is to prevent persons or material from being in the machine's path, even accidentally, posing the danger of being crushed. Each machine once installed must be equipped with a ground enclosure or barrier system. The choice of the most adapted type can be taken by the client or by safety manager of the site, following the norms of relevant country.

The base enclosure supplied as an option by BETA MAX consists of barriers made of metal sections. There is a sliding door (2) on the side facing the loading unit, equipped with an electromechanical interlock system. The mechanical interlock prevents the base enclosure door from being opened if the machine's loading unit is not stationary and properly positioned in front of it. The electric interlock prevents the loading unit from moving if the base enclosure door is open or not closed properly. The base enclosure is completely reversible, meaning that the panels and the door can be mounted in any configuration for it to suit any site layout. The base enclosure is protected against corrosion by means of an epoxy powder coating and hot galvanization.

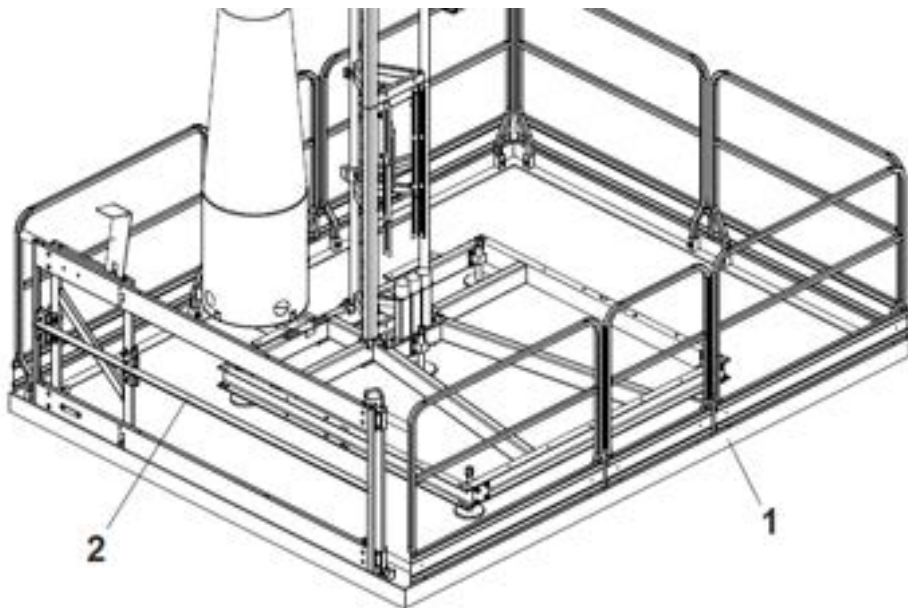

Figure 3.4

### 3.4.3 Vertical mast unit

The machine uses a triangular section mast. The mast is an upright prism measuring 15.75 inches per side and 57.4 inches in height.

The mast is a lattice beam consisting of main vertical supports (1) in circular cross-sectional rods having a diameter of 1.9 inches, joined together by electro-welding in Greek key design (2), made of reinforcing rod and other metal sections. The rack (3), module type 8 is welded onto one of the main vertical supports, and at the two extreme ends of the mast there are the connecting flanges (4), which join the other masts. These are joined by means of bolts and nuts, while the perfectly central alignment is guaranteed by four tapered couplings, which are situated inside the rods. Accurate finishing with a numerically controlled machine tool guarantees perfectly parallel sides of the mast, which are perfectly perpendicular to its main axis. Moreover, this process guarantees perfect conformity when passing through the section where two racks are joined.

The masts are protected against corrosion by means of hot galvanization. Their stability and perfect verticality are secured by the wall anchors, which are available in various types and can cover various distances from the wall. The masts also support the electric cable driving devices and cams, which employ the safety system and the regular stop system of the loading unit.

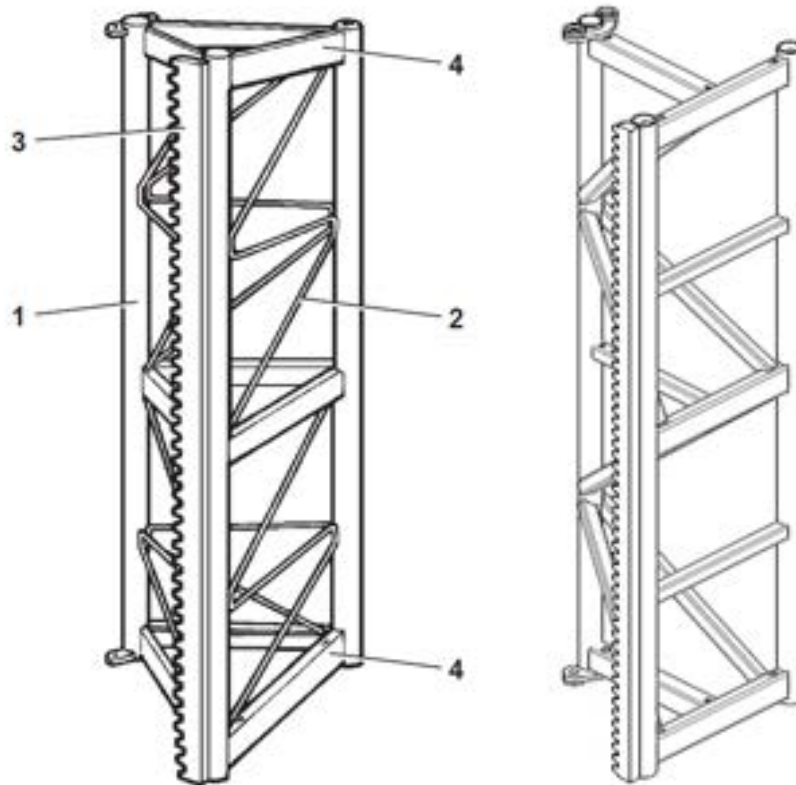

Figure 3.5

### 3.4.4 Loading unit

The loading unit is further divided into four main subunits: the rear part which interfaces with the lifting unit, the enclosure at the front and the two access ramps. The rear part is made of metal sheets, the loading ramps are made of steel sheet metal with anti-sliding bumps, for easy and safe access of platform when materials are loaded or unloaded or when persons passing; the front panel is made of metal sheet. The dumping access ramps allow you to access the loading unit comfortably, constituting a valuable interface between this and the ground floor level or one of the floor levels of the building. The ramps for loading/unloading materials allow the utilization of trucks, wheelbarrows and forklift trucks offering the maximum flexibility of use. The group is designed to allow access from all three sides, for this reason the position of the access ramps can be changed by using special panels sold as an option, at the discretion of the user and per the needs of the site realizing corner fittings etc. The loading ramps are equipped with mechanical locks and a horizontal security bar, to prevent the doors from opening accidentally when the loading unit is in motion, and electrical switches, which interrupt the command circuit and in turn prevent the loading unit from moving if the doors are open or not closed properly.

The loading unit is connected to the lifting unit through fixed hinges and pins that allow mechanical removal.

The loading unit is protected against corrosion: the rear closure, the front panel, and the loading platform by means of an epoxy powder coating. The access ramps are protected against corrosion by means of hot galvanization.

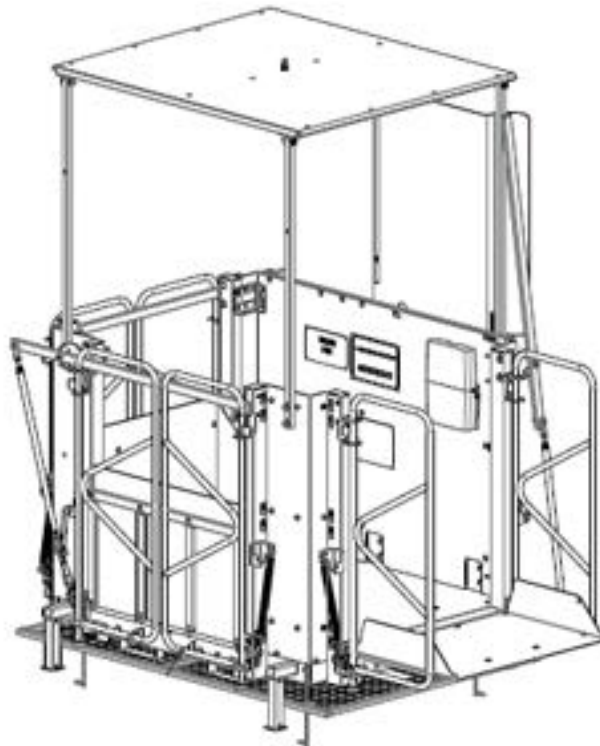

Figure 3.6

### 3.4.5 Lifting unit

The lifting unit is made from metal sections joined with electro-welding and travels along the mast while being held in drive-motion by a series of small wheels on the border of the mast's rails made adjustable by eccentric pins. The motion is guaranteed by mesh of gear with the rack which is welded to the mast. A safety hook (1), placed opposite the motor, has the function of preventing the lifting unit from coming out of its drive mechanism and plunging down should the pin of one or more small sliding wheels happen to break, or if the cabin goes past the last mast installed due to a fault in the loading unit's control system.

All the machine's systems of movement, control and safety are installed on the lifting unit:

- Safety hooks (1)
- Guide rollers (2)
- Safety brake (3)
- Gear-motor (4)
- Up stop switch (5)
- Down stop switch (6)
- Overtravel switch (7)
- 3Mt switch (8)
- Mast presence switch (9)
- Floor stop sensor (10)
- Safety brake detection switch (11)
- Overload control device (12-14)

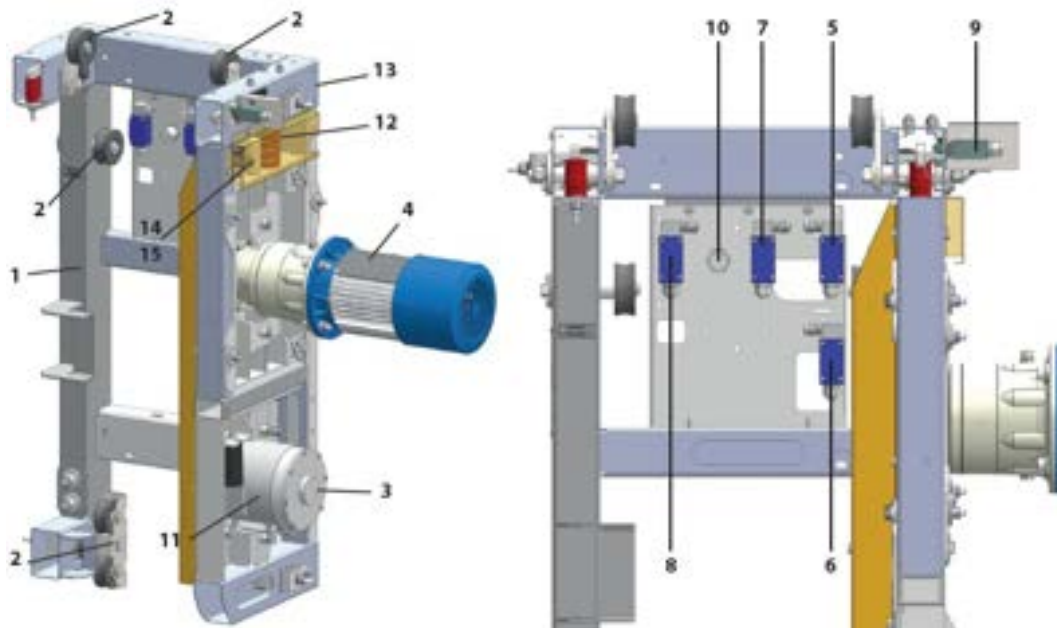

Figure 3.7

### 3.4.6 Floor landing unit

The floor landing equipment consists of sliding doors for Transport Platform applications (fig. 3.8), or full height hinged doors for Material Hoist applications (fig. 3.9), which are designed to prevent accidental access to the machine's path and supply proper protection to prevent accidental falling of persons or materials present on working floor.

The doors at the floor level are installed in the building, close to the machine's path and must interface with the loading unit, supplying a safe passage from the floor to the machine and vice versa. They are also equipped with an electromechanical interlock system and prevent the machine from operating if the doors are open. This characteristic avoids the possibility that the operator could move the machine before having closed the door and therefore prevent from leaving the area without protection.

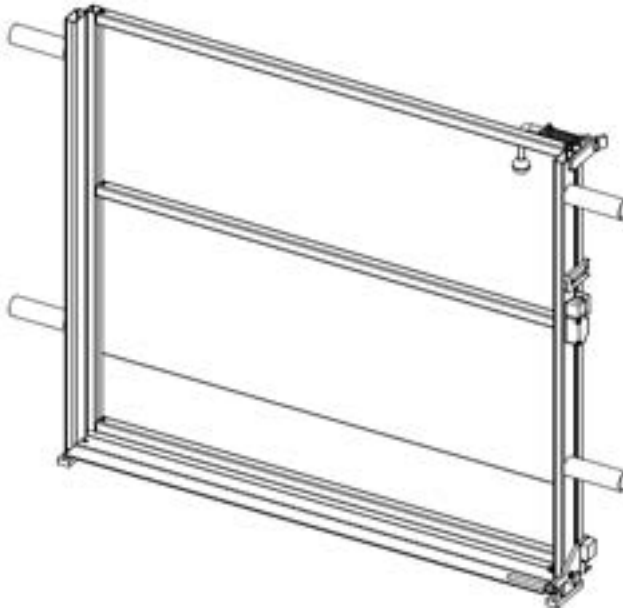

Figure 3.8



Figure 3.9

#### **NOTE:**

The landing equipment, if requested by local laws, can be supplied under specific customer request.

### 3.4.7 Electric cable guide unit

To prevent the electric cable from getting caught on to the mast, an anchor, the rough edges of the building, etc., because of the wind, and consequently ripped from the moving cabin, the machine is equipped with an electric cable guiding system. This system is composed of:

- electric cable container
- electric cable guide frames

The electric cable container (4) coils up the electric cable at the base, in a safe and orderly manner per the natural coil of the cable itself, ensuring it is wound and unwound adequately. The electric cable guide is made of a metal frame (2) that is fixed to the rod on the rear side of the mast, at regular intervals (depending on the windiness of the area where the installation is carried out). The end part of the cable guide forms a sort of ring shape, with one side made of two supports (3) in flexible rubber. The electric cable that is supported and driven by the lifting unit (1), passes from the inner part of these rings situated all along the machine's path and is contained very well to prevent it from swinging sideways.

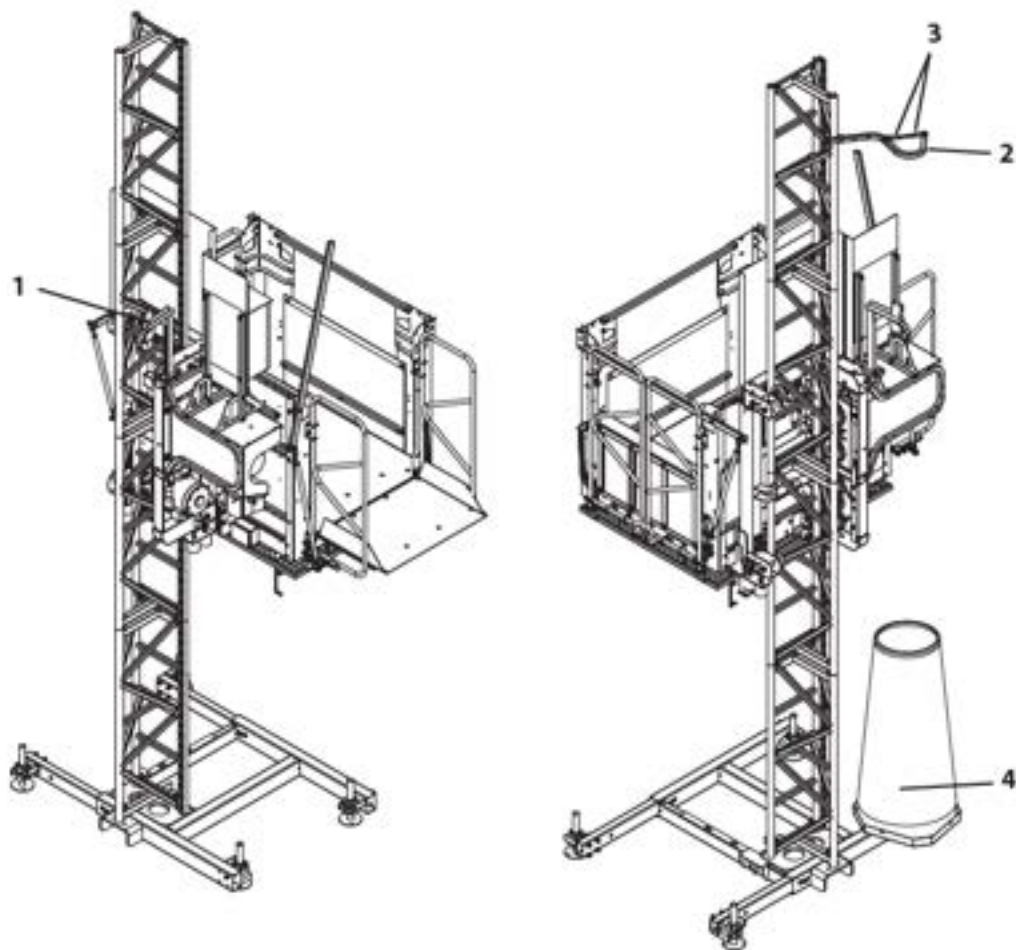

Figure 3.10

### 3.4.8 Electrical equipment

The electrical equipment supplied as standard with the machine, complies with European Community directives and is designed in accordance with European standards and regulations. This equipment is normally supplied when no specific requests are made or when the destination countries accept European standards. The electrical equipment can be different for each machine, in accordance with the specific rules and regulations of the destination country of the machine. The electrical equipment is also designed according to the operating conditions of where assembly will take place (when requested and where possible). All components of the electrical equipment are checked, tested and in conformity with the following national and international standards: IEC, CEE, EN, DIN, UL, CSA, SS, ISO, and UNI. To satisfy the client's specific demands and comply with the various machinery regulations, the electrical equipment is designed specifically for each machine installation (when necessary). All documentation related to the electrical equipment, including the wiring diagram, list of components, etc. is available in the relevant paragraph of this manual as well as inside the electrical control panel box.

### 3.4.9 Electrical settings

The machine is equipped with two electrical control panels:

- the BASE CONTROL PANEL (ground box) found on the base unit of the machine
- the ONBOARD CONTROL PANEL (cabin box) found onboard of the loading unit

### 3.4.9.1 Base control panel

The base control panel (1), supported by adequate support, is mounted on the machine near the access door of the base enclosure. This control panel supplies power to the machine and to the onboard control panel and serves as an interface between the floor-level calling system (when present).

The following components are installed on the base control panel: the power plug, the main power switch, the control and warning devices and the connectors to connect the control panels. An appropriate closure cap is supplied for each connector; in case the machine does not have the relative command or control mechanism. Moreover, to protect the power line, a circuit breaker is placed inside the base control panel, which prevents a power surge or short circuit occurring in the main electric power cable.

#### **NOTE:**

For the detailed description of the mechanisms installed on the control panel, please refer to Chapter 7 "COMMAND AND CONTROL DEVICES" in this manual

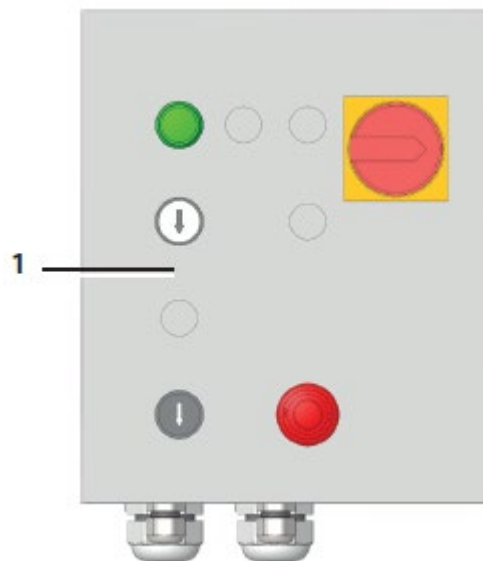

Figure 3.11

### 3.4.9.2 Onboard control panel

The onboard control panel, found in the lifting unit, has the control function of the machine. The following components are installed on the onboard control panel: the main power switch, the control and warning devices, the connectors to connect the control panels and a socket to supply power to an installation transformer.

An appropriate closure cap is supplied for each connector; in case the machine does not have the relative command or control mechanism.

#### **NOTE:**

For the detailed description of the mechanisms installed on the control panel, please refer to Chapter 7 "COMMAND AND CONTROL DEVICES" in this manual.

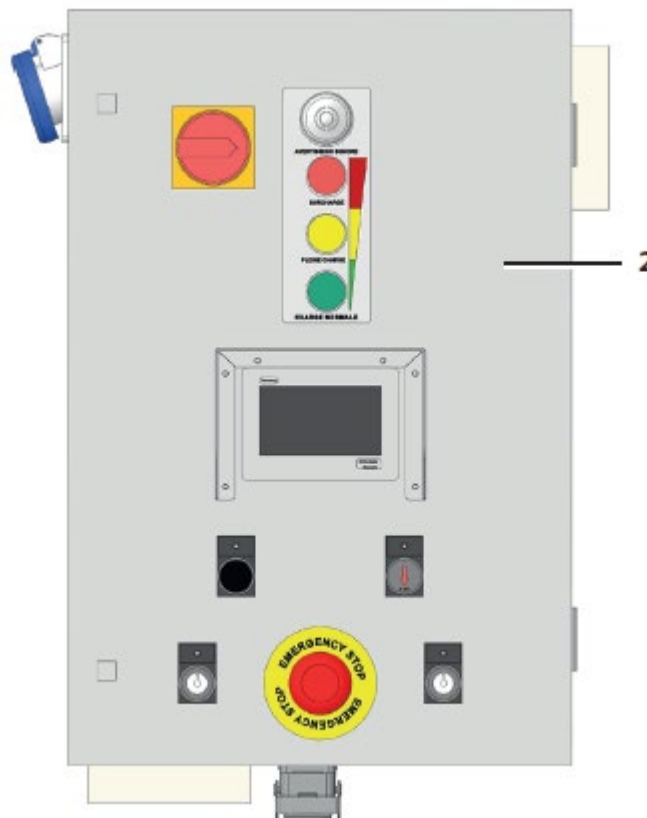

Figure 3.12

### 3.4.10 Control Keyboard

If the machine is installed as a Transport Platform, it can **ONLY** be controlled by the one who operates inside the cabin. If the machine is installed as a Material Hoist, the operator can make the call by means of the ground control pendant or a floor call box, found close to the door of the floor.

The ground control station (fig. 3.13) consists of command pushbuttons (button to call the machine up, one to call the machine down, and one to engage the operation controls and bypass a floor level) and a red EMERGENCY pushbutton.

The floor call box (fig. 3.14) consists of command pushbuttons (button to call the machine up, one to call the machine down, and one to engage the operation controls and bypass a floor level) and a red EMERGENCY pushbutton.

#### NOTE:

For the detailed description of the controls installed on the control panel, please refer to Chapter 7 "COMMAND AND CONTROL DEVICES" in this manual.



Figure 3.13

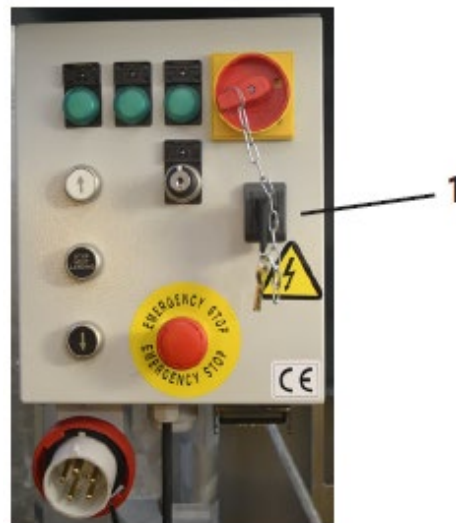

Figure 3.14

### 3.4.11 Centrifugal Safety Brake Unit

The safety brake (1) is a device, which intervenes and stops the loading unit, smoothly and steadily, in case of an excessive speed of descent. Moreover, the safety brake is equipped with a switch that intervenes by interrupting the power supply of the main contactor after which it will not be possible to put the machine back on until the cause which provoked the intervention is identified and resolved. The safety brake consists of a shaft which bears a pinion at its extreme front end, which is permanently engaged with the rack, while bearing a centrifugal device with a swinging hinge at its extreme rear end. If the speed of descent of the loading unit exceeds the threshold set on the safety brake, the hinge releases itself from its idle position, engages with the brakes and starts its braking function on the machine. The braking torque transmitted to the pinion is secured by a stack of a cap spring that are set in the rear part of the safety brake, and a screw device that has the function of increasing the load, which is driven directly by the pinion, onto the washers. Irrespective of the load found on the lifting unit, this system guarantees a constant.

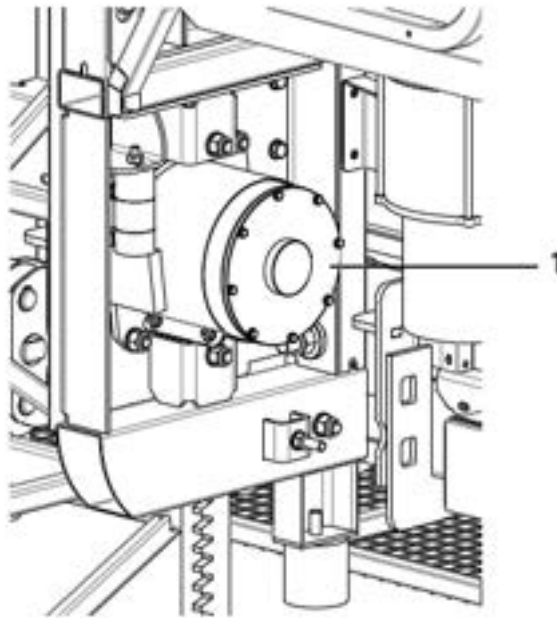

Figure 3.15

The machine is equipped with a drop test pendant (2) for the "drop test" to be carried out. This test makes it possible to verify perfect functionality of the safety brake system and is carried out with every new installation as well as periodically. After each test, the intervention system must be restored by following the instructions in the relevant paragraph. The safety brake device is equipped with a grease nipple for lubrication of the pinion shaft.

### **DANGER:**

The operator is authorized to carry out the restore operations exclusively as described in the relevant paragraph; any other intervention, disassembly, adjustment, etc. is to be implemented solely by BETA MAX Technical Support, which disclaims all responsibility if it has been tampered with. Since the safety brake is a delicate component of particular importance, it must be sent to BETA MAX Technical Support, every five years to be tested and when its operation mode is restored. The safety brake will be returned with the relevant verification stamp. BETA MAX disclaims all responsibility if the user does not comply with this procedure.



Figure 3.16

### 3.4.12 Wall anchors unit

If the machine is installed at a height higher than the maximum allowed in free mast, it must always have the vertical component anchored to the structure of the building at regular intervals to guarantee complete reliability in respect to safety regulations. The anchors must be set in place by means suitable for this use, such as hydraulic platforms, traditional scaffolding towers or by making use of any balconies the building may have etc. In any case, the operator must be equipped with all personal protection equipment, as expected, such as safety harnesses, safety shoes, hard hats, gloves etc. Moreover, this operation must be carried out by taking all the necessary precautions based on experience and good practice of those who work at heights. More information and precautions on how to operate will be given further on in this manual. However, the user is obliged to verify the chosen structure's suitability in withstanding the force exerted by the anchors and utilize mounting components such as anchor bolts, which are suitable for the type of wall to which the machine is to be anchored.

The anchor system consists of the following components:

The anchor system for rectangular section mast consists of the following components:

- Wall anchor extension bar (1)
- Wall anchor extension bar (2)
- Wall anchor fixing plate (3)
- Diagonal joint (4) between the extensions
- Anti-twist frame (5)

Wall extensions that are very long can cause problems of rigidity of the anchorage, in these cases it is necessary to use a diagonal joint between the extensions.

For a detailed description of the wall anchors, technical specifications, force exerted by the anchors onto the structures, implementation methods and information on all accessories supplied with the machine, refer to the appropriate chapter.

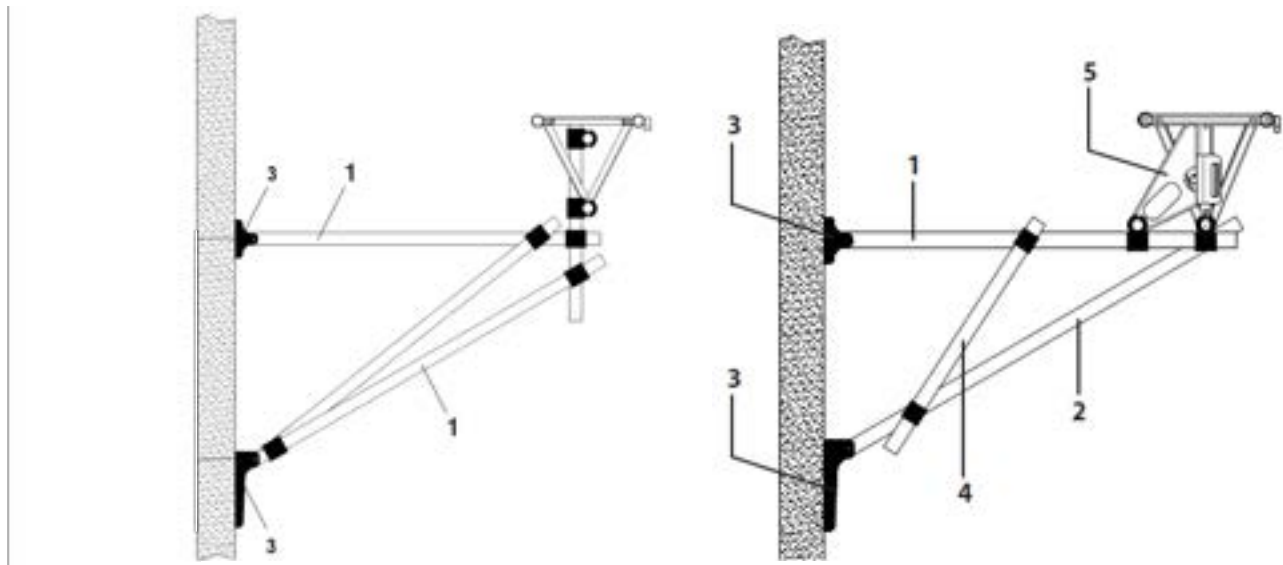

Figure 3.17

### 3.4.13 Platform for anchors mounting unit (erection platform)

To perform the mounting of the mast and of the anchorage devices it is possible to operate from the loading unit or by opening a retractable platform.

The mounting platform is a safe and comfortable terrace which stretches towards the wall allowing for easy installation of the anchoring structure. The platform is made of metal profiles, and its working platform (4) is made of embossed aluminum sheet metal. The platform used for mounting the anchors is an integral part of the loading unit and can be opened and closed whilst operating in absolute safety from inside it. The platform is conveniently equipped with guard rails on all four sides, to prevent the operator from falling off. Mobile parts of the platform are controlled by a switch which prevents the machine from moving if those parts are open or not properly closed. Appropriate hooks for the safety belts are placed onboard the platform and together with other individual protection gear, are obligatory to be used by the operator when mounting the wall anchors.

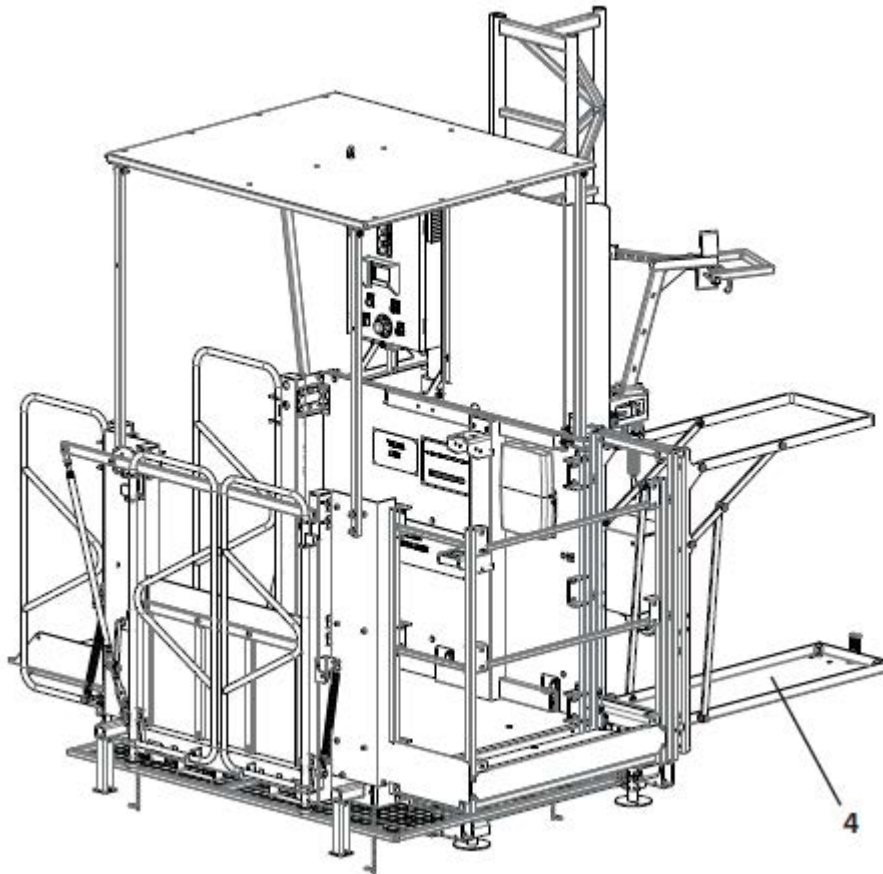

Figure 3.18

### 3.4.14 Accessories

The machine has different groups or accessory devices which can be supplied and installed upon request. The following accessories:

- overload control device
- mast automatic greasing device
- protection roof

#### **OVERLOAD CONTROL DEVICE**

The device acted to check the transported load is made essentially of a load cell (1) (if equipped) connected to the lifting unit (2), an acoustic signal device (3) and of a series of signal lights (4) placed on the onboard control panel (5) to warn the operator of the different load conditions.

The cell detects the transported load and by approaching the limit value or its overcome, the machine turns on the yellow or red light and activates the buzzer to alert operators of reached conditions.

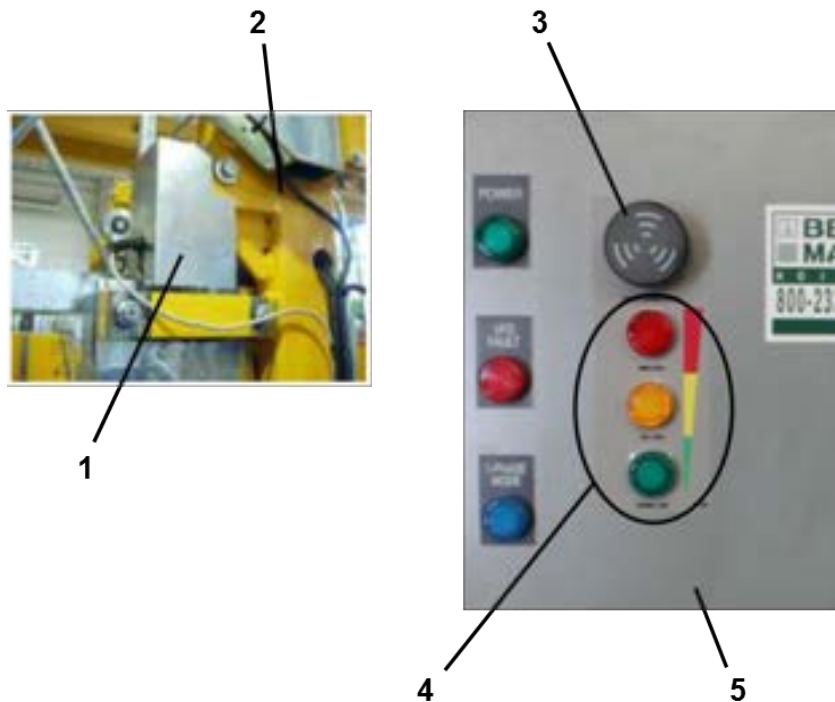

Figure 3.19

### ***Mast automatic greasing device***

The mast automatic greasing device is formed of a container (1) for the solid grease, of a device (2) for the grease distribution and of tubes (3) to be positioned at the lifting unit to distribute grease at the lubrication points. The device is automatically activated by the movement of the machine.

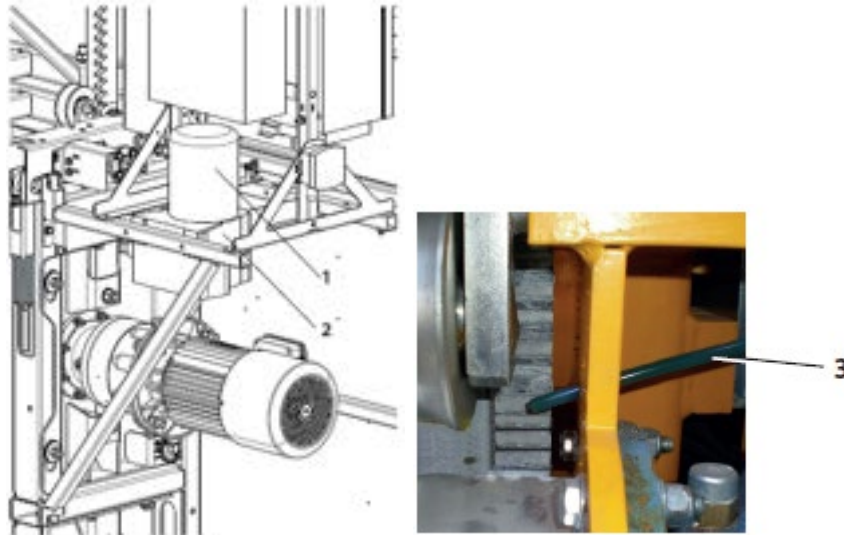

Figure 3.20

### ***Protection roof***

The protection roof is a very useful accessory. It protects workers against weather conditions, but first against accidental materials fall from above floors during the machine use. It's composed of a metallic adjustable structure fixed to the base and frontal panels of loading unit, and a steel or aluminum cover.



Figure 3.21

### 3.5 TECHNICAL SPECIFICATIONS OF THE MACHINE

#### 3.5.1 General data

Lifting speed (Transport Platform mode) .....	40 ft/min
(Material Hoist mode) .....	80 ft/min
Safety brake intervention speed .....	98 ft/min
Max. wind speed allowed during installation .....	28 mph
Max. wind speed allowed when in operation .....	40 mph
Max. wind speed allowed when not in operation (machine on the ground) .....	78 mph
Number of motors installed .....	1

#### 3.5.2 Electrical specifications of the machine

Lifting power consumption .....	7.5 kW
Supply voltage .....	208Vac-230Vac
Power frequency .....	60 Hz
Voltage of the controls .....	24 Vac
Frequency of the controls .....	60 Hz

#### 3.5.3 Electrical Specifications of the Machine

Lifting power consumption .....	7.5 kW
Absorbed current .....	45.5 A
Max. in-rush current .....	54 A
Required power line (Single Phase) .....	230Vac-1PH-50A
(Three Phase) .....	208Vac-3PH-50A
Power cable section .....	see Chapter 6

#### 3.5.4 Manufacturing Characteristics of the Electric Motors

Type .....	self-braking three-phase
Motor size 4.8 kW .....	112
Construction design .....	B5
Protection against the elements .....	IP54
Number of poles .....	4
Service factor .....	S3
Isolation class .....	F

#### 3.5.5 Technical Specifications of Electric motors

Rated output .....	4.8 kW
Revolutions for minute .....	1700
Rated voltage .....	208/230Vac-3 PH
Rated current .....	17.8 A
Inrush current .....	54 A
Motor connection .....	Delta/Wye
Power factor .....	0.82 cos
Frequency .....	60 Hz
Brake rated voltage .....	208V-1PH
Frequency of the controls .....	60 Hz
Electrical isolation class .....	F
Motor weight 4.8 kW .....	94 lbs.



### 3.5.6 Dimensions and capacities

Loading unit internal dimensions S	53.04 in. x 39.36 in.
Loading unit internal dimensions M	78.72 in. x 55.08 in.
Loading unit working surface S	14.50 ft <sup>2</sup>
Loading unit working surface M	30.11 ft <sup>2</sup>
Dimensions of access ramp	34.25 in. x 24.4 in.
Rated load	see following paragraph
Number of persons onboard (during assembly)	2
Max. lifting height with anchored mast	400 ft
Max. free-standing height allowed when in operation	see chapter 4
Max. free-standing height allowed when not in operation	0 ft
Max. height of first anchor	see chapter 4
Max. distance between anchors	see chapter 4
Max. height after the last anchor	see chapter 4





### 3.5.7 Dimensions and weights

Collapsed height for transportation	95.6 in
Minimum height from the ground to the loading unit's floor level	15.7 in
Height of the vertical masts	57.4 in
Rack block	8
Complete base weight	385 Lbs
Complete lifting unit	837 Lbs
Complete loading unit weight S	794 lbs
Complete loading unit weight M	992 lbs
Weight of each vertical mast	121 lbs
Complete wall anchor weight	93 lbs
Base unit dimensions	99.6 in. x 89.4 in. x 86.6 in
Weight of the complete base unit S	2072 lbs
Weight of the complete base unit M	2270 lbs

### 3.5.8 Loads/load capacity

Below are the machine’s load characteristics pertaining to persons and material that may be transported.

MC1600TP/M V installed as a Transport Platform may have a maximum of 4 people (including the operator) and an additional weight of 800 lbs. (**ANSI/SAIA A92.10**)

<b>CAPACITY</b> (LBS)	<b>1600</b>
	<b>+1400</b>
	<b>+1200</b>
	<b>+1000</b>
	<b>+800</b>

10-009

Figure 3.22

MC1600TP/M V installed as a Material Hoist may have a maximum of 1600 lbs. and “**NO RIDERS ARE ALLOWED**” (ANSI/ASSE A10.5)

**ATTENTION:**

MC1600TP/M in material hoist mode is not allowed to have riders during operation except for erection, dismantle, and servicing by authorized and trained personnel.

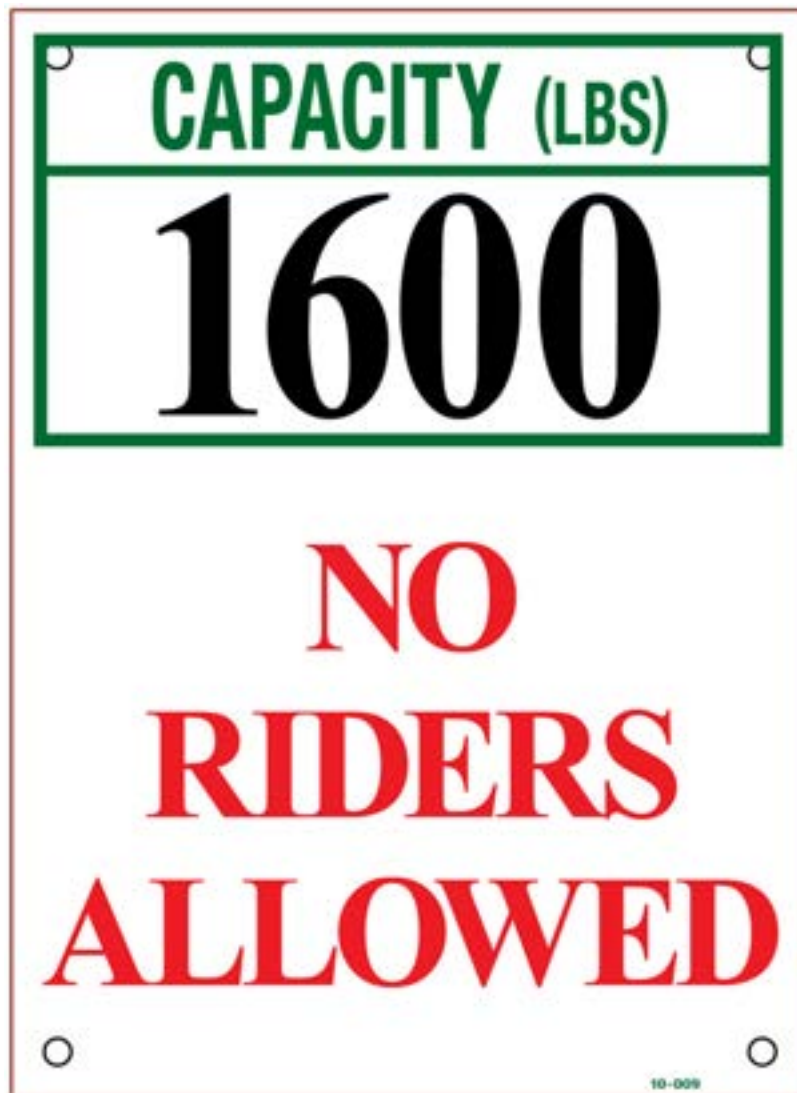

Figure 3.23



### 3.5.9 Safety equipment

Downward overtravel device.....	YES
Upward overtravel device.....	YES
Downward stopping device.....	YES
Upward stopping device.....	YES
Floor-level semi-automatic stopping device.....	YES
Device to stop at three meters from ground.....	YES
Mast presence control device.....	YES
Floor-level calling device.....	Optional
Electromechanical anti-fall device (SAFETY BRAKE) .....	YES
Controls the operation of the parachute device.....	YES
Electric interlock system for the access ramp.....	YES
Mechanical interlock system for the access ramp.....	YES
Electric interlock system for the anchors mounting platform.....	YES
Electric interlock system for the base enclosure doors.....	YES
Electric motors overload device.....	YES
Power line protection device.....	YES
Machine mode selector.....	YES
Manual brake release for emergency descent.....	YES
Automatic electric motor brake when power supply is interrupted .....	YES
Overload control device.....	YES

### 3.5.10 Recommended tightening torques

The table below lists the wrench sizes to be used, and tightening torques recommended for the various sizes of bolts that are to be tightened.

Thread size	Wrench size	Tightening torque	
		Nm	ft-lb
M 6	10 mm	10	7
M 8	13 mm	24	18
M 10	17 mm	47	35
M 12	19 mm	81	60
M 14	22 mm	128	94
M 16	24 mm	198	146
M 20	30 mm	386	285
M 24	36 mm	668	493

The table is applicable to galvanized nuts and bolts with a resistance class of 8.8 and have dry threads.

**ATTENTION:**

Tighten the M16x160 and M16x70 mast bolts on triangular mast to 120 **Nm**  
**(88 ft-lb).**

On rectangular mast to 130Nm **(95 ft-lb).**

### 3.6 INTENDED USE

The machine finds specific application:

- for traditional construction work, facade improvement and general maintenance work
- for work that requires considerable height
- to be used together with traditional scaffolding
- to be used together with a crane tower
- for works carried out with climbing formwork technology

The machine is designed to provide the user with the following advantages:

- transport material, persons and work equipment safely, efficiently and economically
- optimize and rationalize the work process in a modern construction site
- easy assembly and disassembly require only two people
- safety during operation, assembly, disassembly and when the structure may be re-positioned to other parts of the construction site
- conformity with all existing international regulations for this type of machine

#### **DANGER:**

Safe operation of the machine is guaranteed only for the functions and material listed in this instruction manual.

BETA MAX disclaims all responsibility if the machine is not used in accordance with the purposes indicated and in conformity with the instructions stipulated in this manual.

### 3.7 NORMAL CONDITIONS OF STORAGE

Storage of the machine's various components does not require specific environmental conditions. The only recommendation is to store the equipment in a place where water infiltration is avoided as much as possible, as in the long run, this may affect the reliability of the machine's electrical system. Do not cover the machine or its components with synthetic fabrics or plastic to prevent condensation from forming. If the machine and its components are stowed when wet, always ensure that the place where they are stowed is adequately ventilated.

### 3.8 STORAGE CONDITIONS WITH TEMPERATURES REACHING A MINIMUM OF -4°F

If the machine is stored in a closed and heated place to protect it from the elements, no precautions need to be taken, as long as the temperature is kept higher than -4°F. After having stored the machine outdoors, with temperatures close to -4°F, it is necessary to check for any structural damage caused by water infiltration and subsequent freezing.

### 3.9 STORAGE CONDITIONS WITH TEMPERATURES LOWER THAN -4°F

The following precautions must be taken when storage temperatures are lower than -4°F:

- drain the oil from the gear motor;

#### **ATTENTION:**

Always remember to put oil in the gear motor before putting the machine back into operation.

- uninstall the brake rectifiers (guaranteed up to -13°F), and mount them once again before putting the machine back into operation, ensuring that they are connected correctly;
- when the machine is put back into operation, replace the sealing rings of the gear motor's output shaft, as low temperatures change their conformation and no longer guarantee the sealing effect;
- when the machine is put back into operation, replace all bearings, as their protection seals tend to become brittle. Alternatively, when placing the order, you may point out this particular storage condition so that BETA MAX can mount particular bearings which are more suitable;
- to protect the electrical system from damage caused by low temperatures, disassemble the electrical control panel and the motor cable sheaths and store them in a dry, heated place or either way in a place where the temperature is not lower than -4°F.

### 3.10 AMBIENT WORKING CONDITIONS

The machine is designed and constructed to be used in temperature conditions which are not lower than 5°F. If the machine is used at such temperatures, the only requirement is to use lubricating oil for the epicyclical gear system regarding working temperatures ranging from 5°F to 77°F.

Temperatures lower than 5°F do not provide sufficient reliability from the fitting components of the electric motors, generators, etc. and more importantly from the mechanical behavior of the machine's structural components, as they tend to weaken at low temperatures. Therefore, in either case, do not start-up the machine if the temperature is close to or lower than -4°F.

## CHAPTER 4: WALL ANCHORS

### Record of modifications

Revision	Executor	Date	Description of modification

## 4 WALL ANCHORS

### 4.1 PREAMBLE

The wall anchors are the structural components that confer stability and prevent the machine from tipping over during assembly and disassembly, but above all, they reduce and contain the “slenderness” of the vertical mast, always within specific safety values.

#### **ATTENTION:**

A machine installed with a height higher than the maximum allowed in free mast, must always be anchored to the facade of the structure in question.

When a prismatic column is subject to high compressive stresses, or to a peak load (the vertical mast is a classic example) lateral buckling can occur, thus creating very dangerous situations. Such conditions occur when the compressed column is excessively “slender”.

“Slenderness” refers to the ratio of the effective length of a mast to the least radius of gyration of its cross-section.

As mentioned earlier on, the vertical mast usually reaches a considerable height for installation to be carried out, and the ratio between its length and its cross-section results in having an unacceptable “slenderness”. This condition would cause lateral buckling, which would result in structural failure. The anchors are the bond between the mast and the structure in question and prevent such an incident from happening by reducing the free-standing length of the mast to reach safety values. The reason behind this necessary preamble is to (moderately) highlight and stress the importance of the wall anchors.

The next few pages refer to the recommendations and emphasis on operating with utmost attention when handling its implementation, paying particular attention to the quality and type of walling, the choice of mounting components (anchor bolts, chemical dowels, etc.), the actual physical labor required, verification of the effective hold of the mounting components and the layout of the anchors required, in accordance with any particular situations within the construction site.

#### **ATTENTION:**

The wall anchors are one of the most important structural components of the machine. They ensure that the vertical mast maintains its verticality and confers its static stability. Integrity and efficiency of the wall anchors must be checked frequently while using the machine. The practical work related to the anchors must be left in the hands of personnel who have expertise, and consequently, the efficiency and effectiveness of the hold of the mounting components must be meticulously verified.

#### **DANGER:**

An approximate and superficial assessment of the installation conditions is the greatest and most common cause of accidents, often with a fatal outcome.

In any case, the maximum distance allowed between the machine base and the first anchor, and that allowed between all other anchors and that allowed for the mast after the last anchor, must never be exceeded.

**DANGER:**

**A machine installed with a vertical mast height that exceeds what is described in Section 4.2.4 *“Mounting conditions for a free-standing mast.”* must always be anchored to the facade of the served structure.**

Moreover, the operator must be certain of the forces exerted by the anchor system onto the structure in question and verify that this is suitable to withstand them; he must make the right choice when deciding upon the mounting components in accordance with the facade’s walling. If the machine is anchored to traditional scaffolding, the layout must be considered appropriately. Any layout of anchors which is not given in this manual may only be implemented if it has been brought to the attention of an explicit authorization is given by BETA MAX. The implementation of the anchors must be carried out solely by means of the proper mounting platform, or by using methods of equal efficacy and safety, such as hydraulic baskets, traditional scaffolding towers, balconies which the building may have etc. However, individual protection gear must be utilized anyway, such as a safety belt, hard hat, safety shoes and gloves. It is absolutely prohibited to lean over or operate from outside the platform used for mounting the anchors or the loading platform; any operation must be carried out from inside the structures mentioned earlier on, as shown in figure, or by utilizing means which have similar safety features. It is also absolutely prohibited to climb onto and/or to operate from the vertical mast or any other protruding part of the machine.

BETA MAX disclaims all responsibility in the instance of operating in conditions which are not specifically authorized or in conditions which are specifically prohibited.

## 4.2 WALL ANCHORS

The wall anchors form the load-bearing structure connecting the vertical components of the machine to either the wall of the building or traditional scaffolding etc. The wall anchors are coupled to the mast's components by means of perpendicular clamps which engage with the rods at the back of the mast, (those which are not already engaged with the loading unit's drive).

The anchor extensions are the components that link the machine's mast to the structure. They are coupled to the mast by means of approved perpendicular joints and to the structure by means of supporting feet. The extension bars are made of a rod with a diameter of 1.9 in and a thickness of 0.12 in with a wall mounting plate. This is normally mounted to the wall by means of anchor bolts which are suitable for the type of walling present in the building; it is possible to use other types of mounting components, however, only after an assessment is carried out, as it depends on the requirements of the construction site. These components are also protected against corrosion as they are treated with electrolytic galvanizing. The mast component is fitted with an anti-twist bracket (1) that counteracts the naturally occurring rotational forces imposed on the mast by the motor. The anchor extensions (2) are equipped with mounting plates (3) which are flexible to adapt to any facade profile, a diagonal rod (5) which is joined to the two extension bars with swivel joints has the function of making the system more rigid, thus preventing the structure from loosening. Optional equipment which may be supplied consists of extension bars which are longer than standard lengths allow installations on any type of building or traditional scaffolding, or they may be used for greater distances between the mast and the wall.

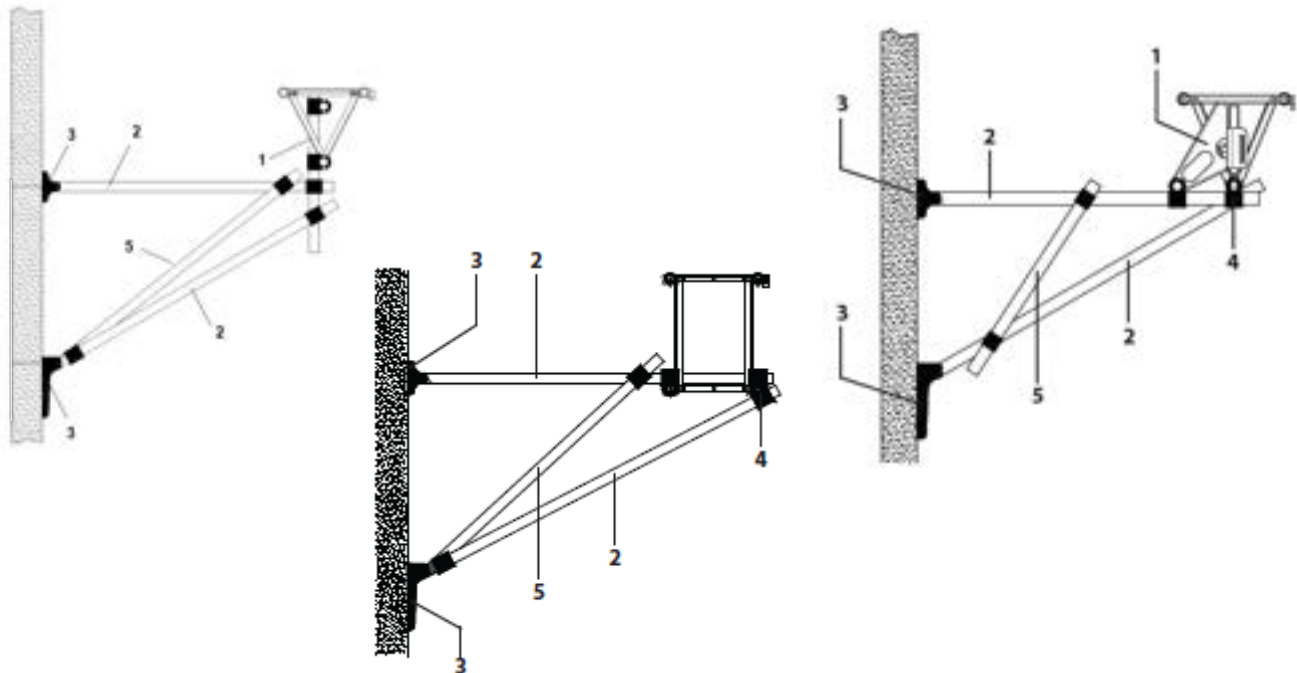

Figure 4.1

#### 4.2.1 Distance between the anchors

The distance between the anchors is determined by several factors such as the conformation of the building to which the machine is to be anchored. It is understood that the maximum distance between two anchors cannot be greater than 24.6 ft.

### **IMPORTANT!!!**

To determine which distances should be applied between the anchors, in any case always refer to the tables shown in the paragraphs which refer to the conditions of assembling the machine and those of the mast's anchor system, paying attention when choosing the values and maintaining accordance with the options available for the base unit installation. Pay attention to and be certain of which classification of wind the installation area falls under and when unsure, keep to the lowest values.

#### 4.2.2 The structure used for anchoring the machine

It may not be possible to maintain the maximum distance allowed all along the entire mast, even though this is the most feasible anchor system. In fact, it mainly depends on the building's conformation or other situations related to the construction site's particular operational requirements etc. If the distance between the anchors needs to be reduced (the only operation allowed), the user must ensure that the distance between the mast's anchors is as uniform as possible.

### **DANGER:**

**IMPORTANT!!!** It is only possible to reduce the maximum distance between the anchors.

#### 4.2.3 Allowed height of the topmost part above the last anchor

The maximum free height over the last anchorage must not in any case exceed the height specified in Section 4.2.5 "Conditions for anchoring the mast" irrespective of the type of anchor used. In any case and always refer to the layouts and tables shown further on, bearing in mind to be certain of which classification of wind the installation area falls under and when unsure, keep to the lowest values.

### **DANGER:**

An approximate assessment of the installation conditions is the greatest and most common cause of accidents.

#### 4.2.4 Mounting conditions for a free-standing mast

The layouts shown below indicate the maximum height of a free-standing mast, which may be installed depending on the type of mounting components used on the underlying foundation base. In particular, the following types of installation can be pointed out:

- installation 1, the machine rests on the foundations, with **no** mechanical mounting components;
- installation 2, the machine is mechanically mounted to the foundations by means of toggle bolts or lag bolts sunken directly into the foundations.

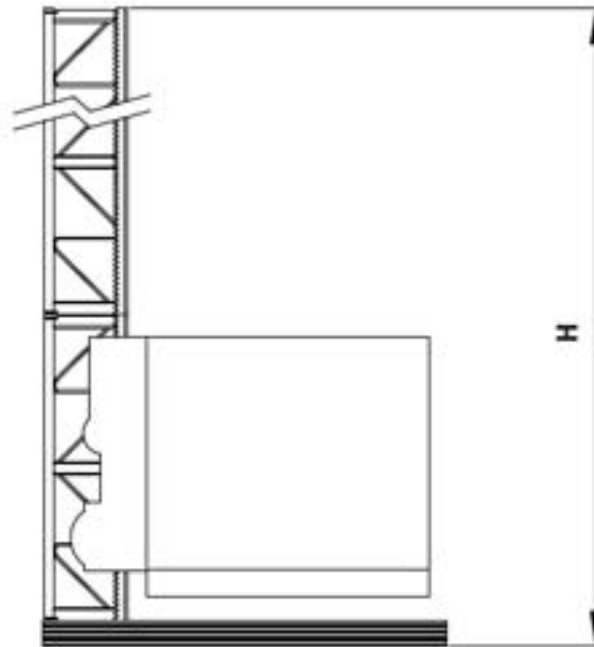

Figure 4.2

	<b>Installation</b>
<b>MC1600TP/M V S</b>	14.76 ft
<b>MC1600TP/M V M</b>	14.76 ft

### **DANGER:**

It is forbidden to use the machine with the free-standing mast measurements exceeding those specified in the table above.

#### 4.2.5 Conditions for anchoring the mast

The layouts shown below indicate the maximum distance there must be between the wall anchors for the machine's vertical mast to be set correctly on machines installed without extensions on the loading unit.

The following types of anchor systems can be pointed out:

- Anchor system 1, the first wall anchor is set at 24.6 ft from the base and the subsequent anchors at a maximum interval of 24.6 ft. The topmost part of the mast after the last anchor cannot and must not exceed 14.76 ft
- Anchor system 2, the first wall anchor is set at 24.6 ft from the base and the subsequent anchors at a maximum interval of 24.6 ft, with the last two anchors at a maximum interval of 9.84 ft. The topmost part of the mast after the last anchor cannot and must not exceed 19.68 ft.

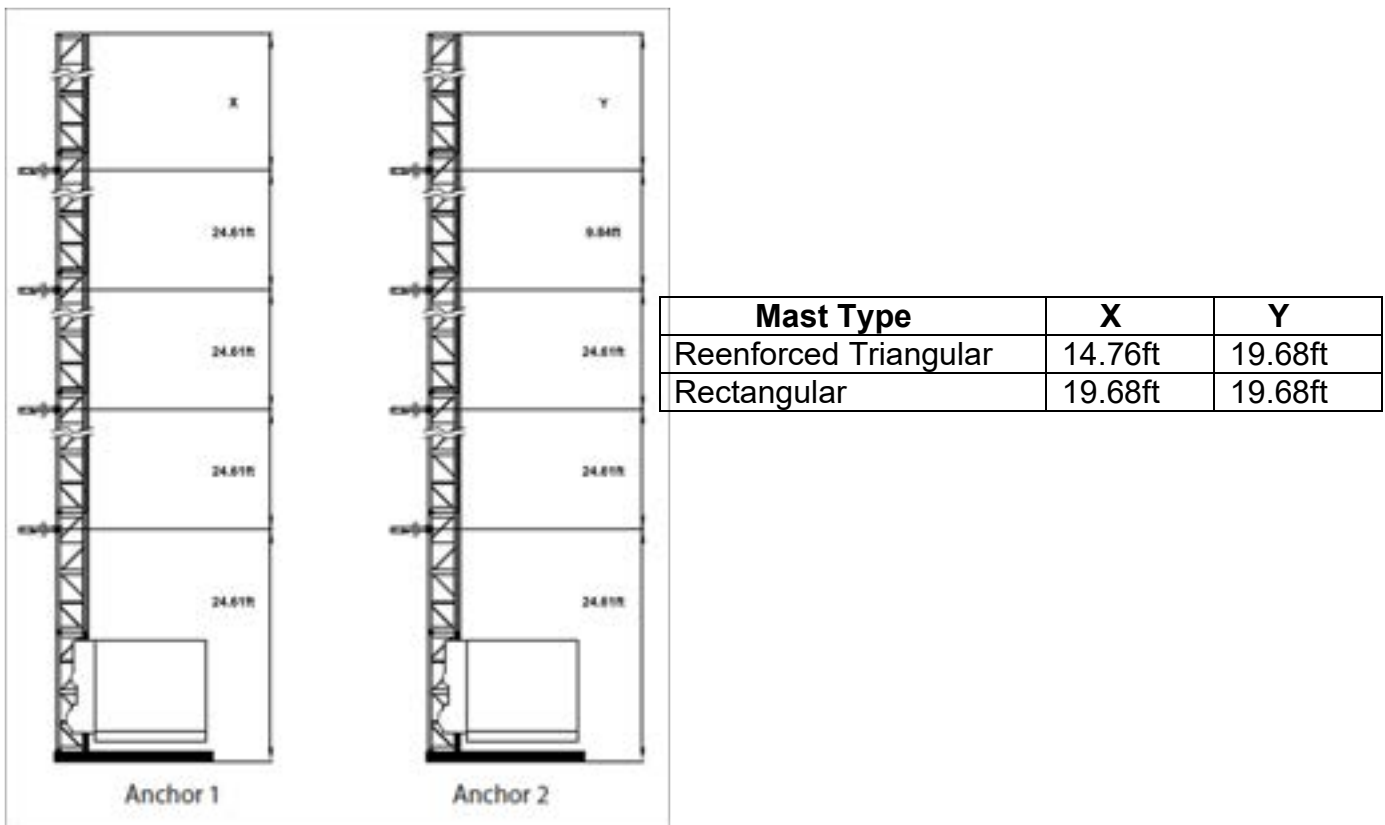

Figure 4.3

### DANGER:

It is forbidden to use the machine with distances between the anchors exceeding those illustrated above. It is also forbidden to use the machine with the topmost part of the mast after the last anchor, exceeding the measurement illustrated above.

#### 4.2.6 Forces onto the wall anchor system

Every anchor extension bar (1) has an anchor point (2) which is fixed to the wall with two mounting components, consisting of wall anchors.

**Every anchor point must be able to withstand a maximal pull-out force due to the stress applied by P1, acting perpendicular to the wall, and the stress applied by F, acting parallel to the wall.**

The forces in question are mainly due to very windy conditions when not in operation, and when the fully loaded platform is in motion or positioned close to the anchor system. Clearly, the building structure onto which the anchor system is applied must be able to withstand the mentioned forces.

If the machine is anchored to traditional scaffolding or some other type of scaffolding, the joints as well as the entire structure must be properly assessed.

If the anchor system is assembled per the standard measurements, the values of the forces exerted by the machine onto the wall are shown in the following table:

FORCES EXERTED ON THE ANCHOR SYSTEM				
	L from - to	B from - to	P1 (daN)	F (daN)
<b>MC1600TP/M V S</b>	<b>33.46 – 49.21 in</b>	<b>21.65–39.37 in</b>	<b>265</b>	<b>180</b>
<b>MC1600TP/M V M</b>	<b>53.14 - 68.89 in</b>	<b>33.45-61.02 in</b>	<b>345</b>	<b>250</b>

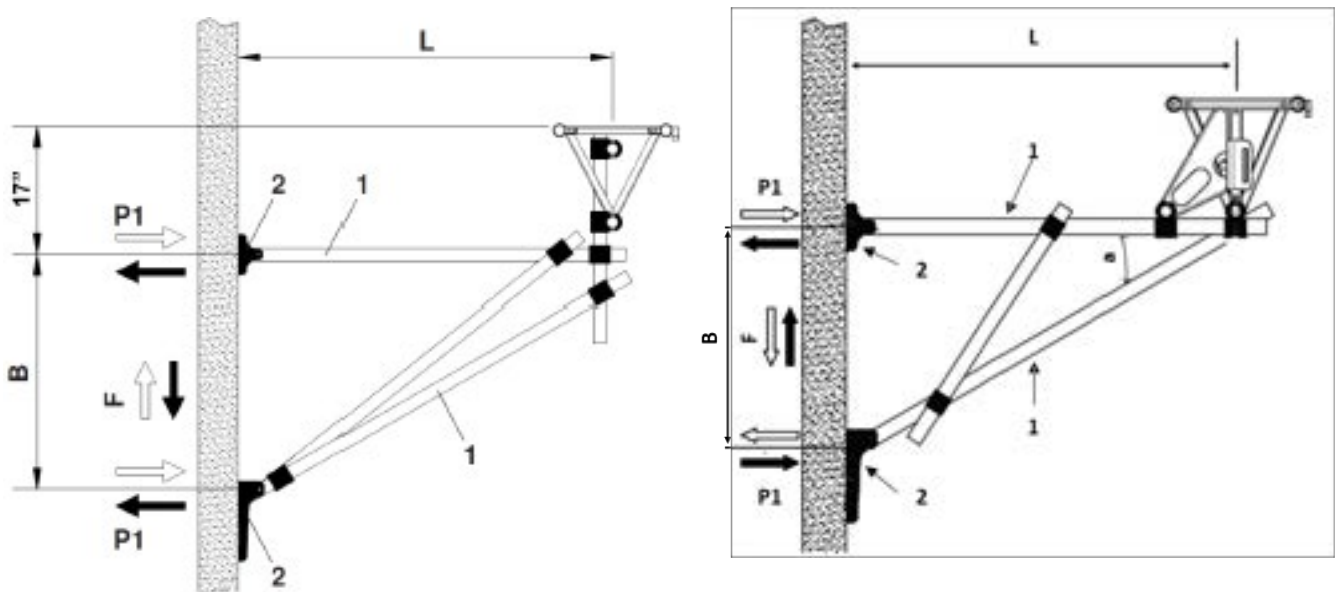

Figure 4.4

Non-standard specifications must be used for the wall assembly if the length of the anchor extensions and the distance between the wall anchors exceed the measurements indicated in the table on the previous page. The stress applied by **P1** and **F** must be calculated bearing the following in mind: that these are a function of force **P** which the machine exerts onto the mast; the distance between the two extension bars (**B**); and the distance from the center of the mast to the wall (**L**).

The formula shown below can be used to determine the values of these forces, where the results are expressed in daN (1 daN = 1 kg).

### ATTENTION:

The formula indicated to calculate the forces exerted on the wall anchors in non-standard assemblies are not applicable to standard assemblies. In the instance of standard assembly, the values shown in the table (on the previous page), derive from structural calculations; in the instance of non-standard assembly, the values derive from simplified formula.

$$P1 = \frac{P \times L}{B} \text{ (daN) with } L \text{ and } B \text{ in inches}$$

$$F = P \text{ (daN) obtained in table}$$

$$\alpha = 30^\circ \pm 5^\circ$$

FORCE EXERTED BY THE MACHINE ONTO THE TRIANGULAR MAST	
	P (daN)
MC1600TP/M V S	265
MC1600TP/M V M	345

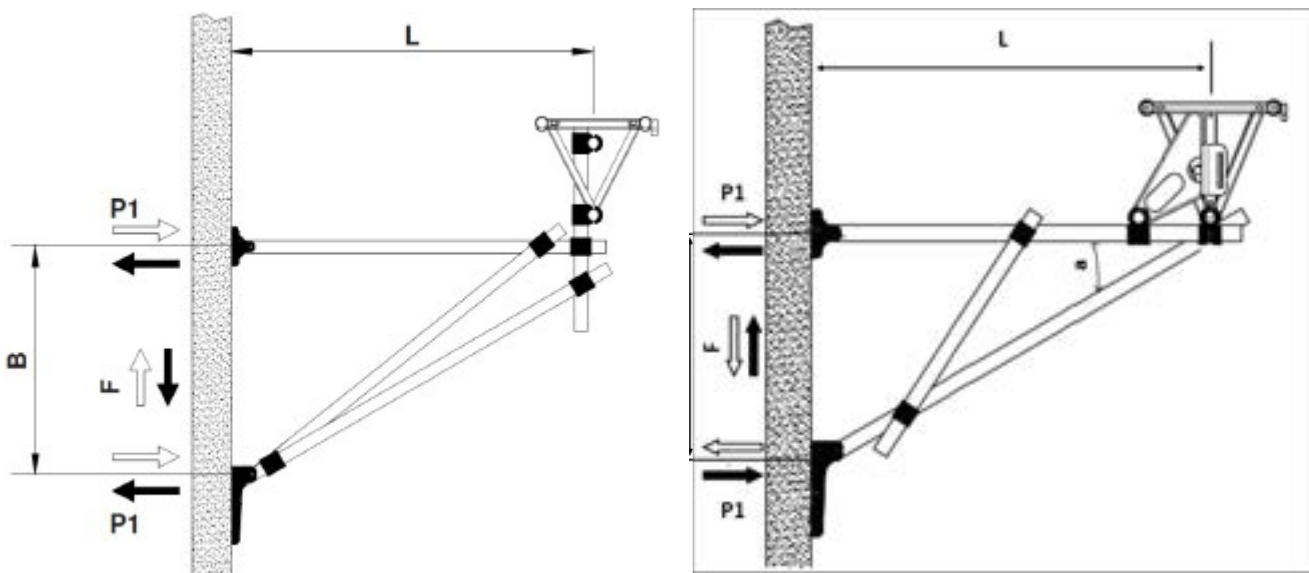
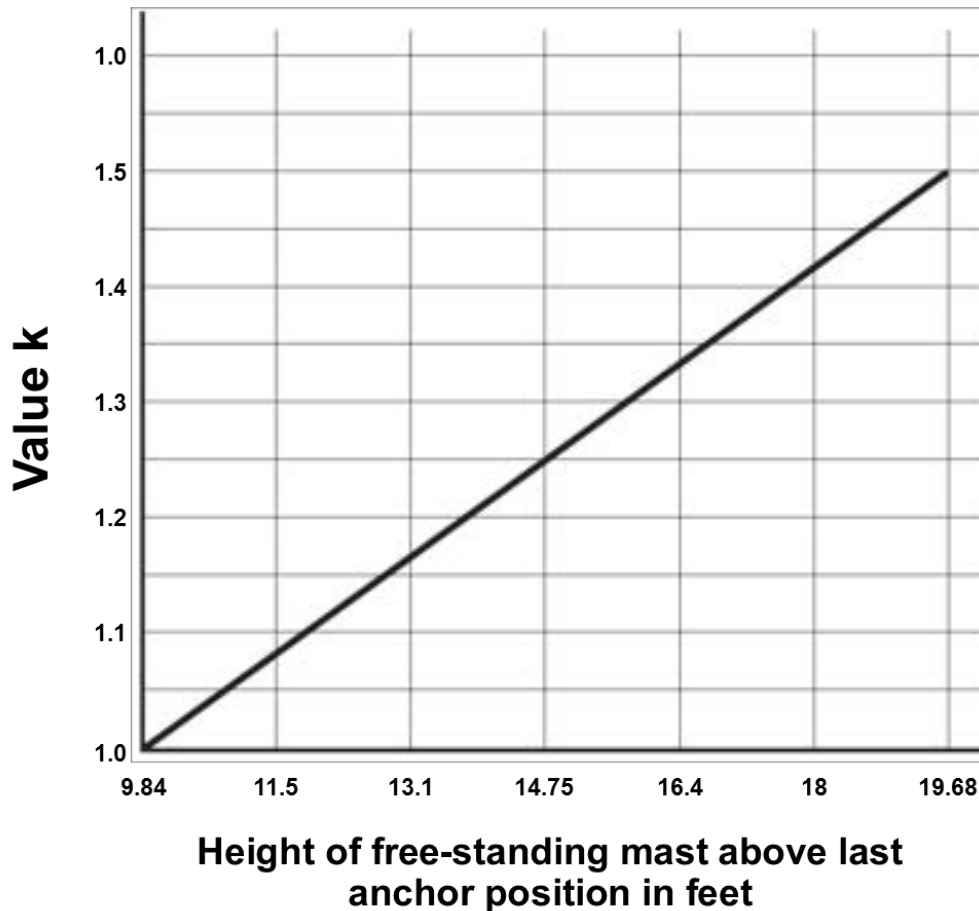

Figure 4.5

If the machine is operated with a free-standing mast exceeding 9.84 ft. in height above the last anchor location, the forces exerted by the last anchor onto the structure must be appropriately increased.

The values **P1** and **F** obtained by following the description given in the previous pages, for a standard assembly as well as for an assembly with measurements which are different from a standard assembly, must be multiplied by value **k** which is established in the diagram below:



*Figure 4.6*

Irrespective of the results obtained, all conditions of installation stipulated in the previous chapters, must be complied with.

Before carrying out the installation, or giving out indications regarding its process, the operator must have perfect knowledge of all that is mentioned above and operate accordingly.

The served build could present geometry not compatible with the dimensions of the anchors described above. In these cases, the anchor can be modified maintaining the same structural strength to fit the characteristics of installation.

**The stresses that the machine imposed on the wall are considered the same as those identified for the standard anchor.**

If the mast has a distance from the wall (d) between 11.81 – 27.56 inches, it is possible to use the pattern in figure 4.7.

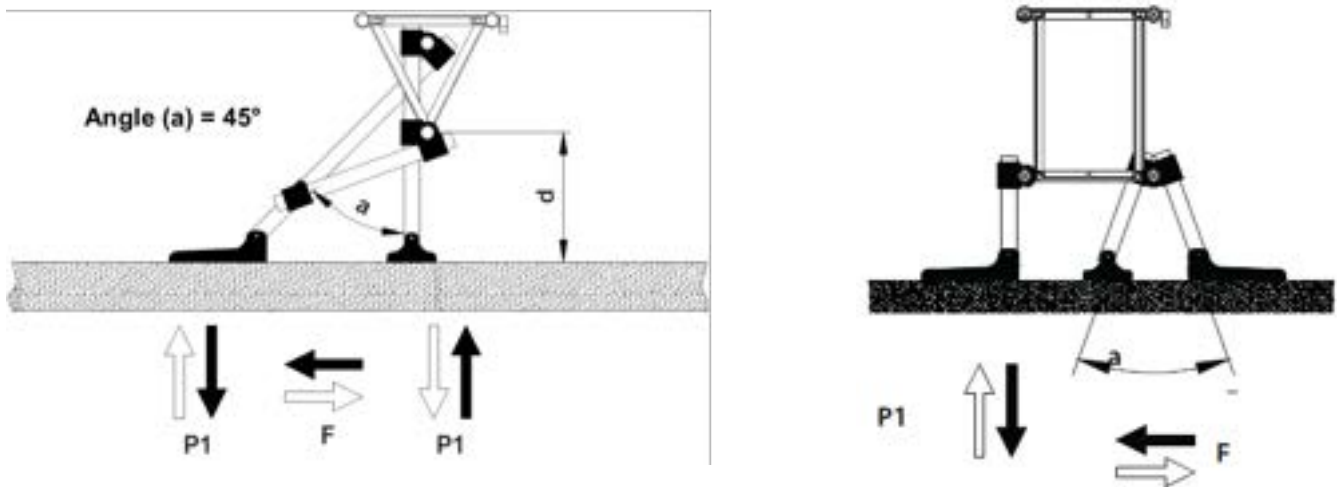

Figure 4.7

If the distance (d) is less than the previous measurements, then it is possible to use the pattern in figure 4.8.

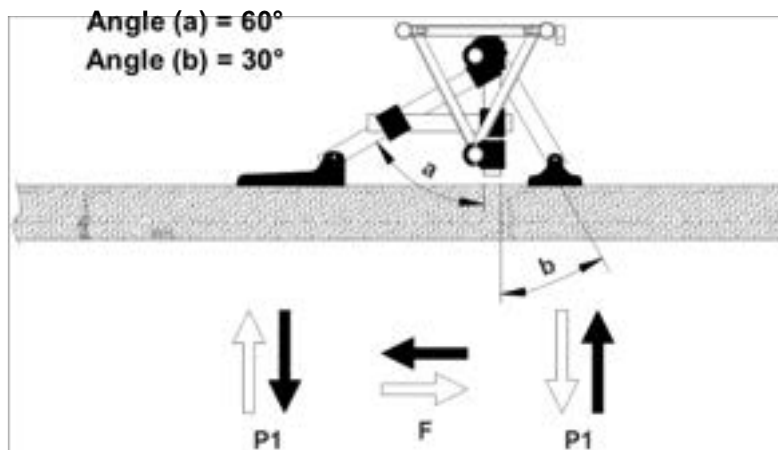

Figure 4.8

The stresses that the machine imposes on the wall are considered the same as those identified for the standard anchor.

In cases where more length on the anchors is necessary, additional support components will be needed to stiffen the structure. Use the following pattern and table:

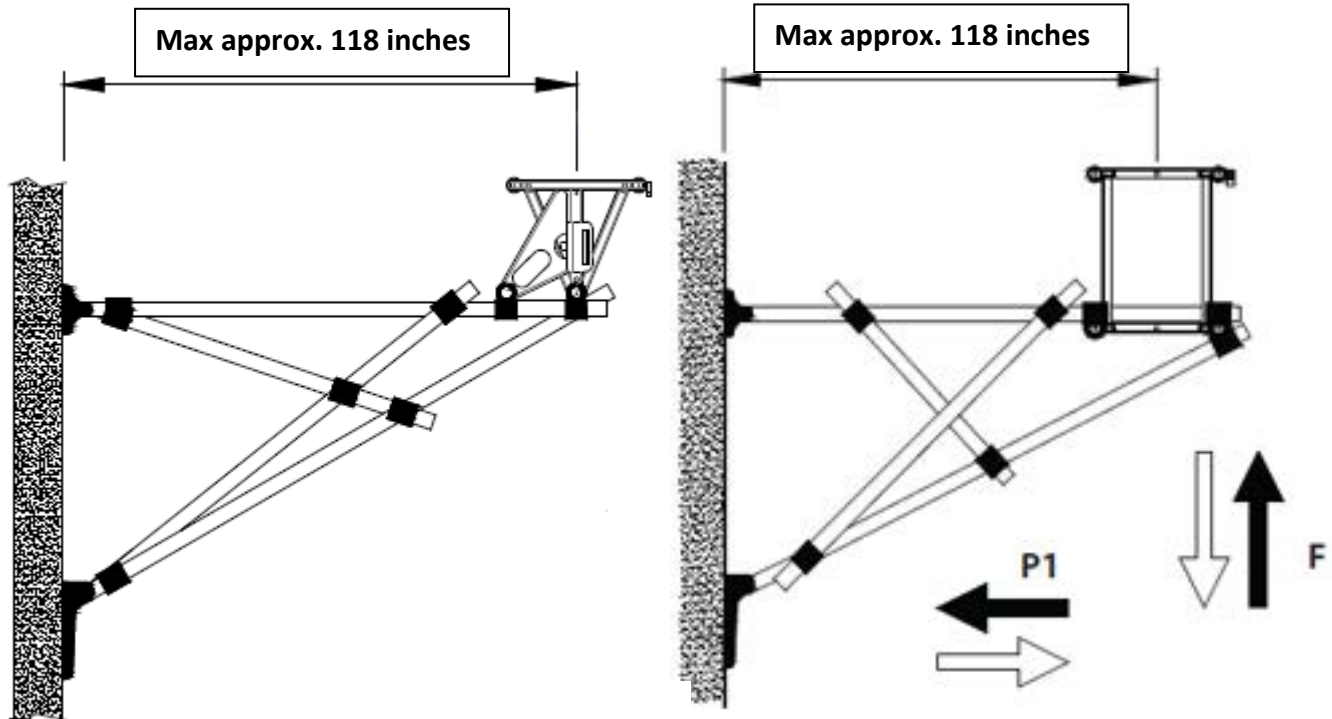

Figure 4.9

	P1 (daN)	F (daN)
MC1600TP/M V S	300	175
MC1600TP/M V M	425	245

The stresses imposed on the wall must be calculated with the formulas above described.

Those types of anchors suggest limiting the distance between mast and served build to about 118 in. so to not have excessive tubes lengths that may have stability problems. In case of special needs for the installation, working conditions must be controlled and have identified an appropriate anchor's pattern for these requirements.

#### 4.2.7 Type of anchor systems

The area of the building that is normally considered the most suitable for the anchor system to be implemented is the string course slab, where the floor is generally made of reinforced concrete and allows you to implement an anchor system which is solid and secure, with the use of anchor bolts that are suitable for the machine.

Solely for illustration purposes, we can say that by implementing an anchor system on reinforced concrete and using appropriate ½" diameter anchors (2 for every extension bar), the pull-out forces are remarkably superior to maximal responses of anchor systems.

However, there are other possible solutions for specific cases, such as:

- the kind of wall of the building, or structures with various conformations (windows, obelisk shaped terraces), which are unable to withstand the above-mentioned forces exerted onto the anchor system
- the work that is to be implemented onto the structure, such as facade improvement using insulating panels, or glass paneling

In exceptional cases, if the building has constructive constraints, in order to remedy the situation, it is possible to implement the loop anchor system directly onto the windows or with the use of metal poles inside the building itself, which link the anchor system; all this allows work with such constraints to be carried out, which would otherwise be impossible.

In cases where particular anchor systems must be implemented, such as only one anchor can be used for every anchor extension or if very long extension bars must be used, it is necessary to use larger anchors and more than one rigidity beam in order to secure the anchor system and make it as safe as possible and in keeping with the normal operating conditions.

Please contact and provide the details to BETA MAX Technical Support to determine whether an on-site visit is necessary to be given advice or any authorization.

However, BETA MAX disclaims all responsibility for causes due to the implementation of particular anchor systems which are not defined nor authorized beforehand by the company itself and also disclaims all responsibility for anchor systems which are not implemented up to standard even if specifically allowed by the builder; this makes it an obligation to contact BETA MAX Technical Support every time a particular installation is necessary.

**IMPORTANT!!!** The operator has the explicit task of supervising and giving adequate instructions on good practice by providing safety procedures for the implementation of such work, ensuring that individual protection gear is used and that the work is carried out in authorized places, supervising the quality of work, for example, ensuring that drills with adequate diameters are used, the holes are of the right depth, that bolts and clamps are tightened in accordance with established torque values etc.

#### 4.2.8 Working conditions with a free-standing mast (not anchored)

The machine is in accordance with the conditions outlined below and can work in free standing mast (not anchored). In this working condition there are two possible configurations of installation: with standard base frame in simple support on the ground and with the base frame fixed to the ground. Refer to the section 4.2.4 “Mounting conditions for a free-standing mast” to get the necessary instructions for maximum free height. For the installation condition that involves the base being anchored carefully read the Chapter 6, Section 6.5 “Foundation for positioning the machine” for the necessary instructions. Be sure to check which class of wind fits the installation area and in case of doubt keep to the most limiting values.

#### 4.2.9 Information for the commissioning of the mast

The mast sections may present a slight deviation with respect to the theoretical form some slight rotation may result in respect to the vertical axis. Such deviations cannot be eliminated as they depend on multiple conditions that may verify during the production stage of the mast sections. The mast sections rotation does not mean that the product is defective but is a normal result of the manufacturing process of such a particular item. The mast sections which have a maximum misalignment not greater than 0.078 in the extreme faces of the principal pipes are to be considered a product without defects. In case the mast rotation may cause a sensible rotation of the machine it's necessary to correct the position of the mast sections using the anchorage system.

**The correction of the rotation of the mast must be performed on each anchor at the moment of its installation. A correction performed after two or three anchors brings the mast to have an overall rotation too large and difficult or impossible to fix. In these cases, the correction could be made only with the application of very large forces.**

To efficiently measure the mast rotation direction, we advise to measure the distance between the external body of the cabin and the wall as indicated at the points **A** and **B** of the figure.

One way to correct the mast rotation, by using the anchorage, is to leave one of the anchorages fixing points away from the wall (it depends on the direction of the rotation to be fixed) and to use the fisher tension to circle the mast as indicated by the arrows in the figure.

### ATTENTION:

To correct the mast rotation, it is possible to use external screw coupling. In this case, pay the maximum attention to not apply extra strength that may deform permanently the anchorage pipes and not to damage the support structure of the machine.

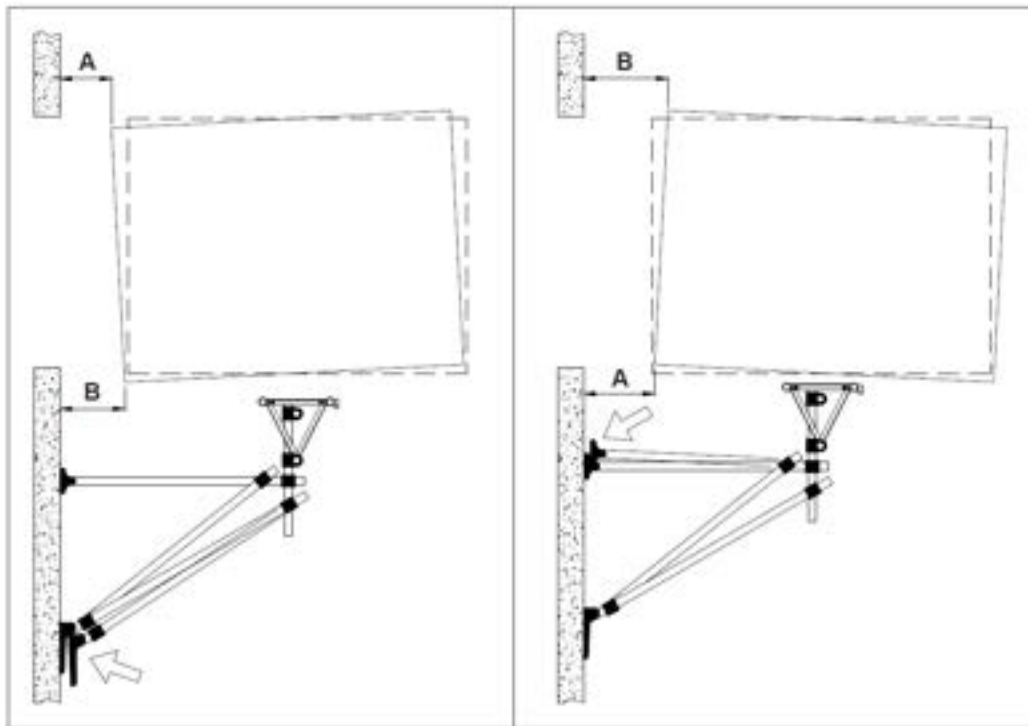

Figure 4.10

#### 4.2.10 Mast anchor frame assembly

The mast anchoring frame (10-520N) is a device that is mounted on the triangular mast to add a rigid anchoring point to reduce the naturally occurring torsion of the mast.



The anchor frame can be mounted independently on the top or bottom of the triangular mast, as shown above. The assembly is inserted in the mast column with the 2 clamps, without tightening any hardware, and slide the frame towards the point of the triangle until the foot contacts the vertical column of the mast.

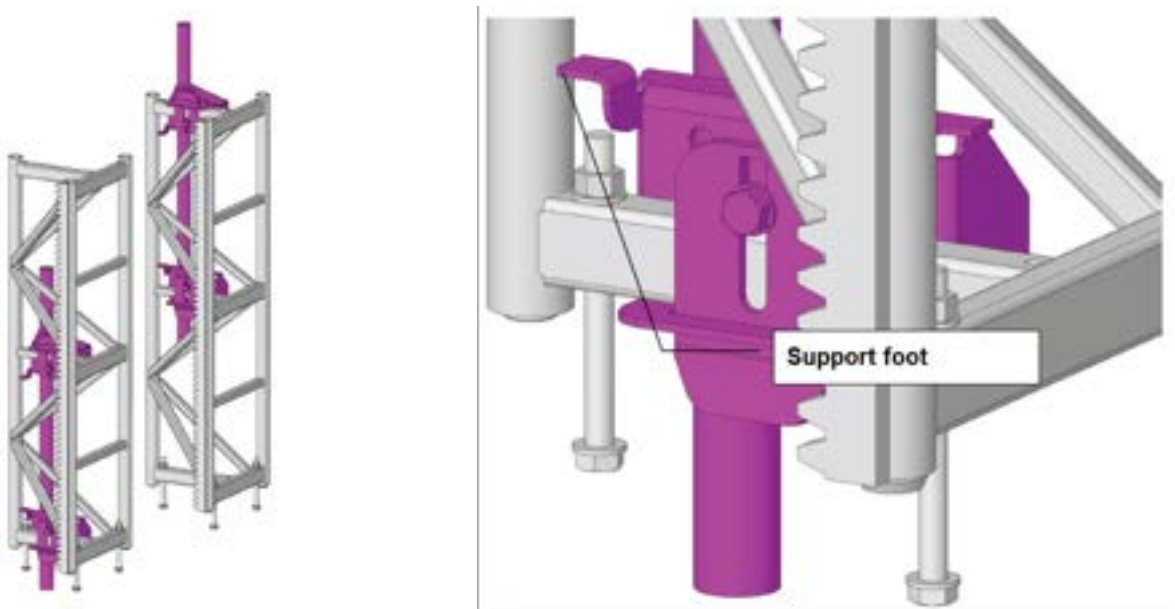

With the anchor frame positioned correctly, tighten the M16 bolt to 120Nm (88ft-lbs) of torque.

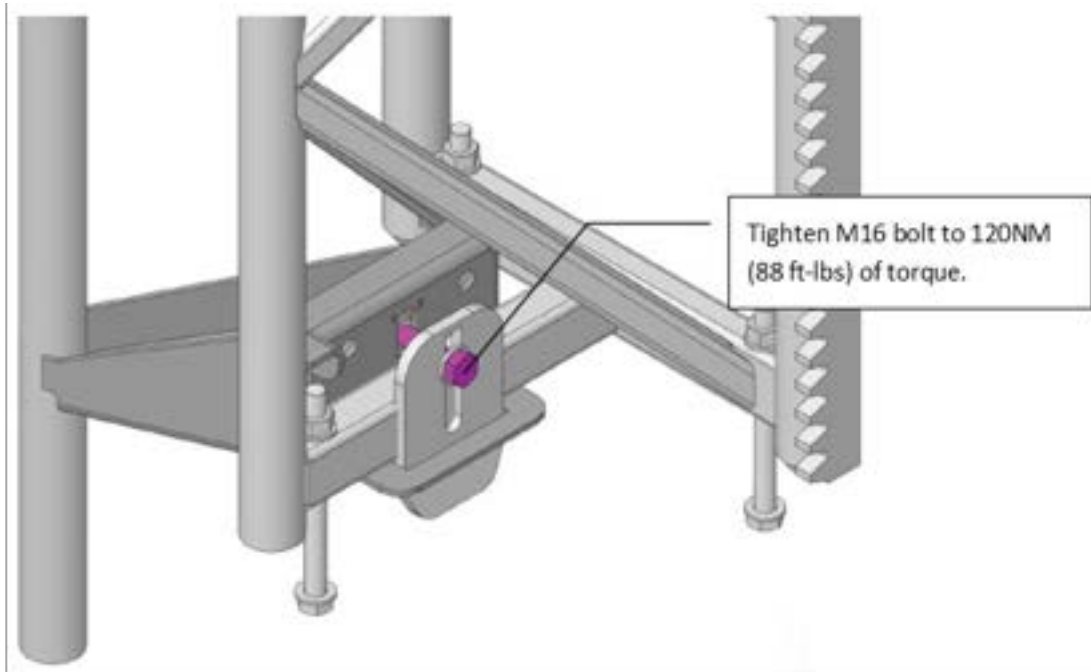

The rear self-locking nut must not be touched; the bolt is screwed into a nut hidden inside a housing. This hidden nut cannot rotate so, tightening of the clamp must be done from the exterior with a wrench.

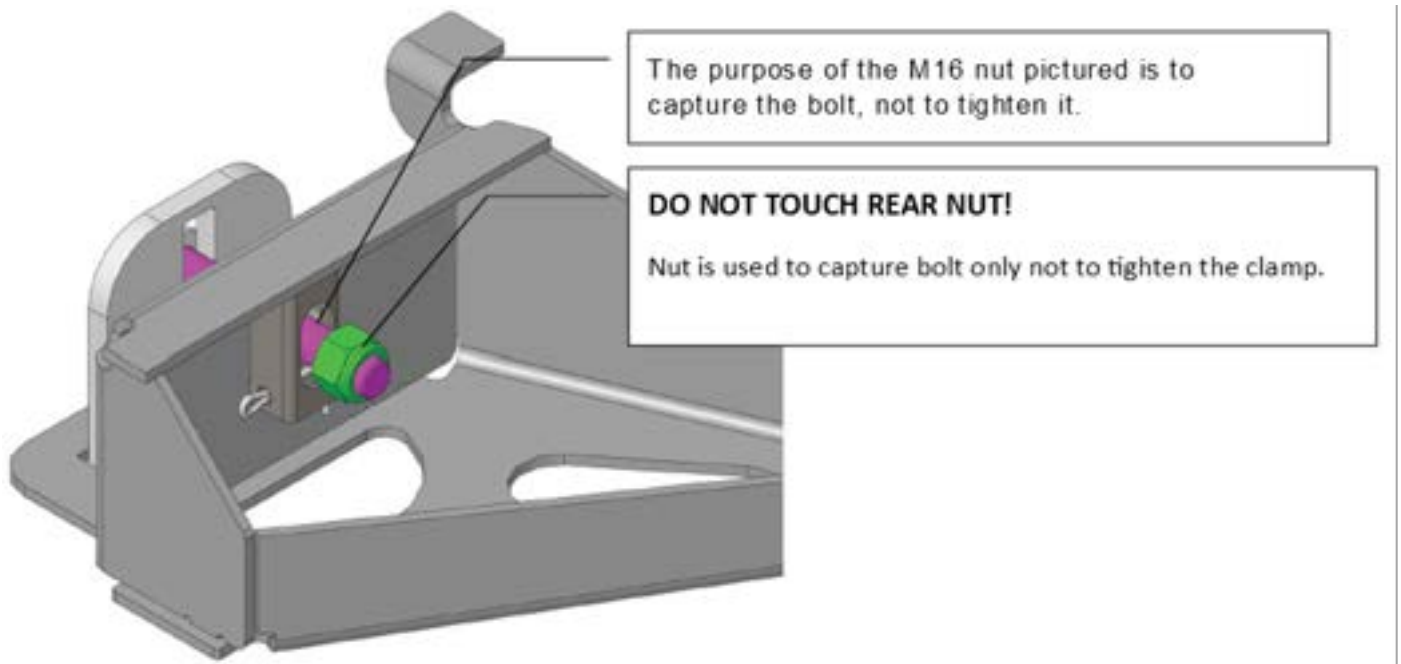

In the standard configuration, the frame mounted on the machine appears as in the following images. (2) wall tie tubes are connected to the anchor frame, and the rotational force of the mast is passed from the mast column to the anchor frame by means of the clamps on the anchor frame itself.

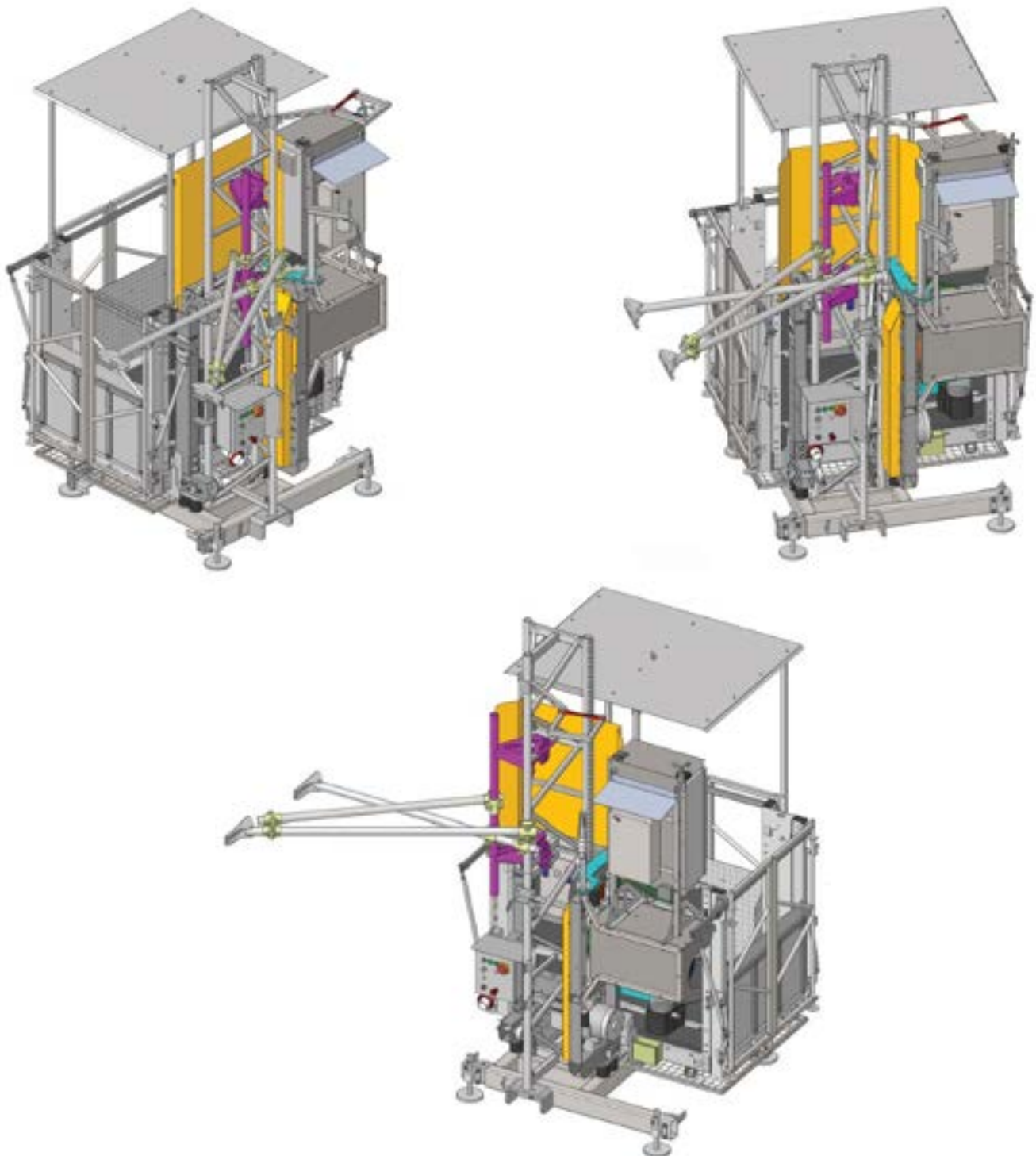

#### 4.2.11 Opposite mounting of wall ties

If necessary, the machine can be installed in a reverse configuration. The mast anchor frame must always be mounted on the opposite side of the mast from the motors, but the ties can run toward the structure located on the motor side of the machine. See the image below:

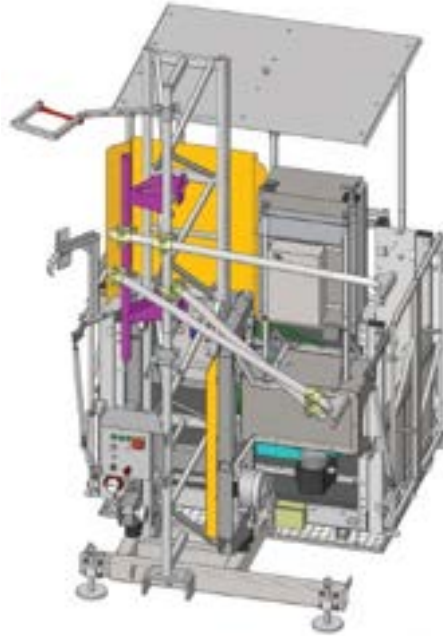

**When installed in this configuration it is necessary to move the trailing cable arm to the opposite side of the mast to avoid collisions with the wall tie assembly.**

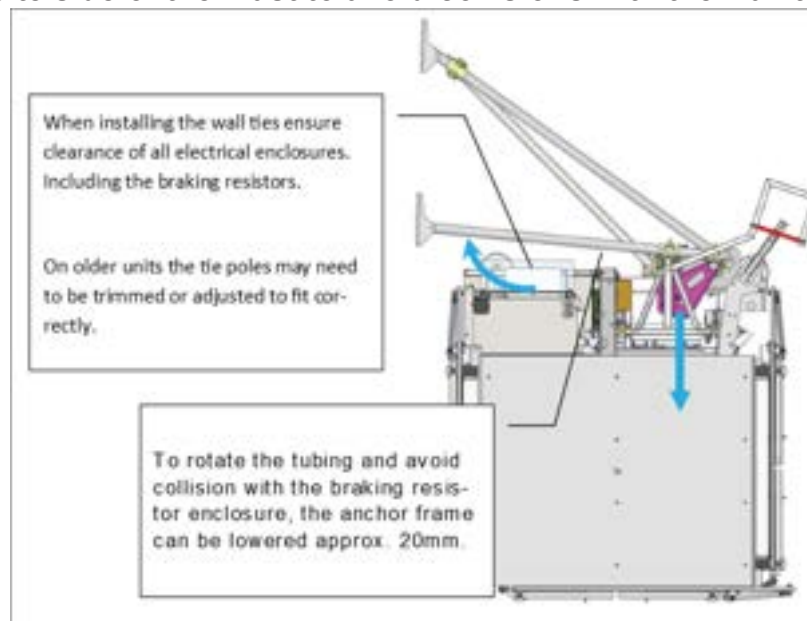

The below detail depicts the orientation of the trailing cable arm when relocated to the opposite side of the mast:

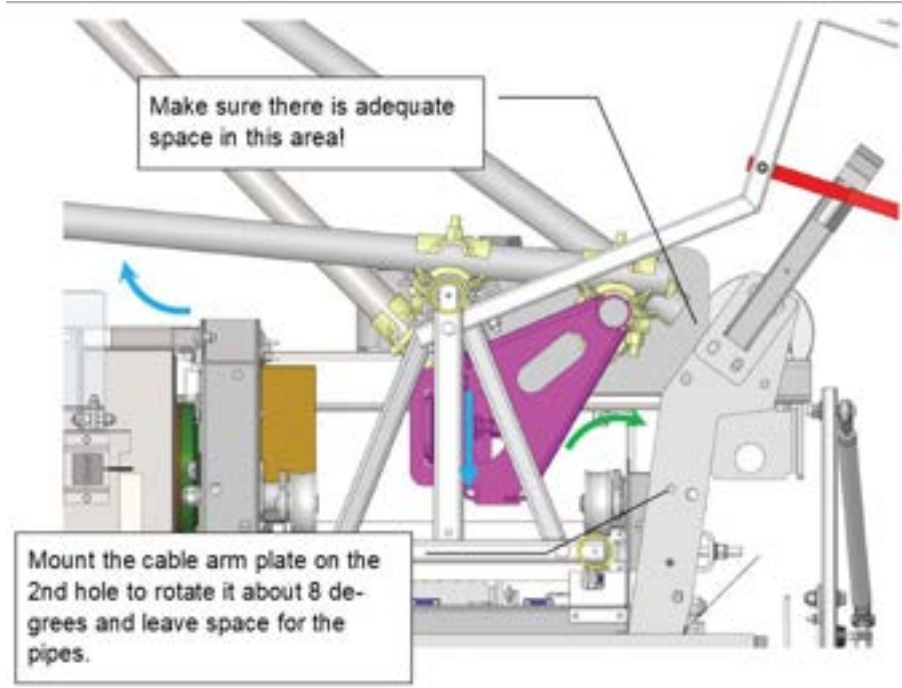

To mount the trailing cable arm on the opposite side of the mast, simply disassemble the cable arm and cable arm support plate. Flip the cable arm support plate over and mount it on the opposite side of the unit. Then reattach the cable arm as seen below:

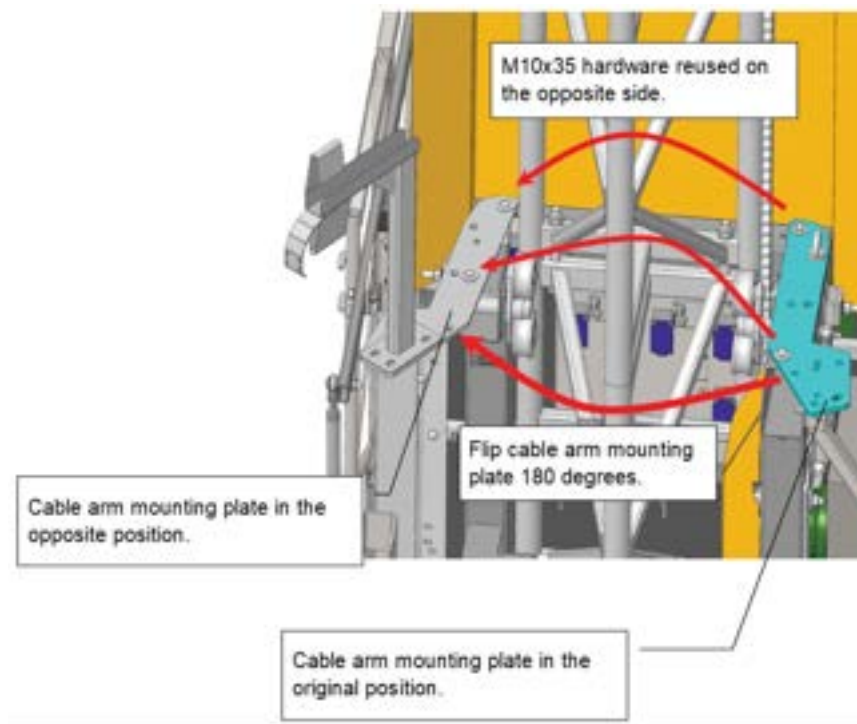

# CHAPTER 5: HANDLING AND TRANSPORTATION

Record of modifications

Revision	Executor	Date	Description of modification

## 5 HANDLING AND TRANSPORTATION

### 5.1 INTRODUCTION AND PRELIMINARY OPERATIONS

The area to be used for preparation of the material, loading, unloading, temporary storage or warehousing must have clear signs and be closed off, in such a way to prevent access to outsiders or anyone not authorized.

#### **ATTENTION:**

The operations of preparing, packaging, transporting, handling, loading, and unloading of the machine, must be carried out by personnel who are experienced and/or properly trained.

The operations of preparing, packaging, handling, loading and unloading the machine must be carried out by personnel who is trained appropriately and effectively and directly monitored by the site manager (SUPERVISOR) who has to ensure that the above-mentioned operations are carried out up to standard, in compliance with all the safety conditions whilst meticulously adhering to the instructions found within this instruction manual.

#### **DANGER:**

An approximate assessment of the installation conditions is the greatest and most common cause of accidents, often with a fatal outcome.

All the components constituting the machine must be meticulously checked and examined before making them available for a new installation, to remove any parts which may be broken, deformed, cracked, corroded, or affected by other factors, and no longer ensure sufficient reliability. Once the load is set in place, one must absolutely ensure its stability, and this must be done with enough belts, ropes etc. arranged in the most appropriate ways and of adequate sturdiness to block the load in question.

#### **ATTENTION:**

The members of staff, qualified and trained in carrying out the operations of preparing, packaging, transporting, handling, loading and unloading the machine, must be equipped with suitable equipment, according to the particular risks they may be exposed to and personal protection equipment such as, work gloves, hard hat, safety footwear with non-slip soles and reinforced metal as well as a toe-cap, safety harness with shoulder straps having hook components, and a high visibility jacket.

## 5.2 TRANSPORTATION

The packaging of the modular components constituting the machine is designed primarily to reduce clutter, as much as possible. It consists of packaging because the various galvanized metal components are tied together in various ways with galvanized mild steel wire but are not placed inside containers. This packaging greatly facilitates the process of unloading the material; it is obligatory to use a crane or a lift truck (forklift) to unload the material, due to the weight as well as for reasons of safety of personnel; moreover, in this way, the material is handled with care when in movement and damage is avoided.

The various small components are placed inside proper packaging, inside appropriate cardboard boxes and these are grouped together with all the machine's accessories.

Both electric control panels are placed onboard the machine and therefore do not require particular attention, apart from the necessary precautions when handling and transporting the machine.

Normally, the same types of components are packed together; the machine components are loaded as follows:

- the first components to be loaded are all the packages of the masts, previously packed together in groups of seven or nine units (depending on the measurement of the loading unit of the transport vehicle). To increase and guarantee greater compactness and stability of the load, the various packages are tied together with galvanized mild steel wire;
- the machine base unit, which consists of all the components constituting the actual machine, is loaded immediately behind the mast components;
- once the machine base unit is positioned in place, the accessories put together are inserted where possible (clamps, wall anchor extensions, floor fixing brackets for the anchor system, set of wrenches furnished with the machine, braking pads, etc.) and when possible, packed inside appropriate cardboard boxes, which can be moved by means of a lift truck in order to facilitate and speed up the processes of loading and unloading in the construction site. This method allows the load to be distributed as uniformly as possible onto the transport vehicle, obtaining a center of gravity position on the vehicle's center line, and placed as close as possible to the axle of the driving wheels.

### 5.3 HANDLING

Transportation of the machine must be carried out in compliance with the Highway Code that is in force in the locality where it must be carried out, even if the distance covered is short, from one construction site to another. With regards to transportation for the first installation, BETA MAX uses a tested positioning system, to place the various components of the machine onto the various transport vehicles. This allows the warehousing department to establish the exact overall dimensions and therefore, the capacity that the transport vehicle is required to have for any type of arrangement of hoist which is to be dispatched. This positioning system is valid for the classic type of transportation by truck as well as for transportation by container. The handling procedure described below can be considered as a rule, applicable for every trip the machine will make during its operational life.

The general criteria to be followed, to avoid any damage when handling the machine when transporting it from one construction site to another, mainly concerns the maneuvers when loading and unloading, which are critical stages during which considerable damage can be done. Consequently, the members of staff who are responsible for these operations must:

- use lift trucks as shown in figure 5.1 when handling the material. A crane can be used figure 5.2 on one forming part of the transportation vehicle itself or any other used in the construction site. It is necessary for the lifting equipment to have adequate strength to lift the load
- always ensure that the material to be lifted, which may consist of a packed group of components or a single component, does not accidentally hook onto other components of the machine, dragging them high up

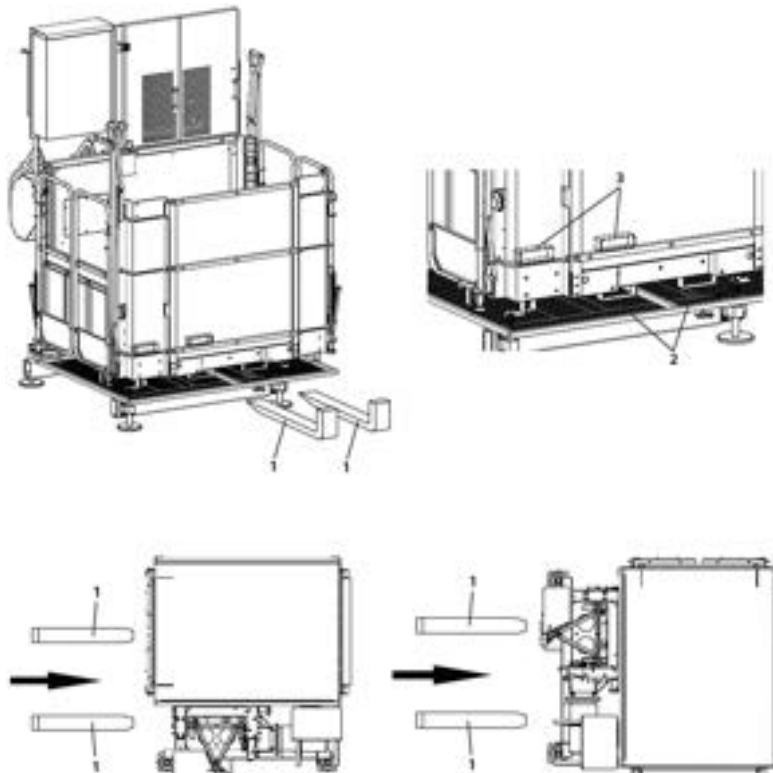

Figure 5.1

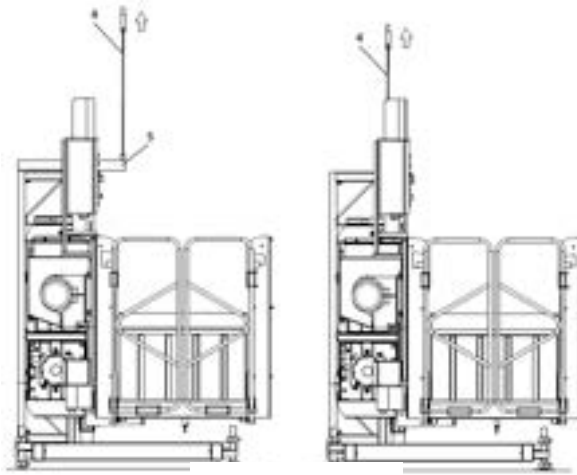

Figure 5.2

- if the package that is being lifted consists of the same type of components and these are joined together, ensure that the binding tie, which usually consists of a tie made with galvanized mild steel wire, is intact and adequately strong enough
- not apply any means to the components of the machine, in any way, to facilitate the lifting process, such as metal eye bolts, which could cause structural damage to various components of the machine
- use flexible belts, which are allowed, arranging them in a suitable layout for the component to be strapped correctly when lifted, in accordance with the load capacity that the belt itself can sustain
- avoid, in every way, knocking the load against any other components of the machine or against the ground
- ensure that when the material is made to rest on the ground, it can maintain its stability

When the machine is lifted, you must avoid this from jerking or swinging abruptly, and you must also pay utmost attention when resting this on the ground, which must be done in such a way so as not to damage the leveling bolts (if presents).

### **DANGER:**

It is absolutely forbidden to stay in the operating area of the lifter while the machine's components are lifted and moved.

### **ATTENTION:**

During the loading/unloading stage, which will be described further on, or any other stages of work that involve lifting material, for no reason whatsoever should anyone pass or stay under the suspended load.

## 5.4 LOADING AND UNLOADING

To optimize all subsequent stages of work, before proceeding to load or unload the machine, carry out the operations described below:

- close off the area where operations of loading and unloading the machine are carried out, in a clear and unequivocal manner, and enclose its perimeter in an effective manner, to prevent possible access to outsiders or persons anyhow not authorized. Bear in mind that the subsequent operations will be implemented at a substantial height from the ground, and should any component or equipment accidentally fall, it can result in immediate danger
- ensure that the ground conditions on which the equipment constituting the machine is to be placed, is horizontal and sufficiently stable, so not to cause dangerous situations of the equipment tipping over, collapsing or subsiding
- unload the machine from the transport vehicle using a crane or lift truck which has an appropriate lifting system. If using a lift truck, the lifting attachments can be placed on the lower part of the base unit. If using a crane, strap the machine from the base unit with belts which have an adequate load capacity. In both cases the machine must be perfectly balanced
- for no reason whatsoever should anyone pass or stay under suspended loads during this stage and the other stages, which will be described further on, of un/loading. If using a crane, only the operator will be authorized to handle the suspended load to facilitate its correct positioning when it reaches a height of 8 in. from the ground. If using a lift truck only the driver of the same truck will be authorized to carry out the operations; all other persons will have to stay at a distance, where they cannot be affected in case of the load accidentally tipping over and they must remain there until the operation is carried out completely. It is necessary for individual protection gear to be worn during these operations
- unload the remaining material and accessories constituting the machine and distribute them in an orderly and safe manner within the closed off area. Ensuring that the material placed on the ground cannot, in any way, accidentally move, constitutes a danger to persons working nearby or subsequently interfere when moving the machine
- if part of the material has been placed in the free spaces inside the machine, or components have been placed in rows lying on top of each other (to optimize space allocation), remove the material from this layout and place it on the ground before carrying out any other handling operation

### **DANGER:**

Close off the area where operations of loading and unloading the machine are carried out, in a clear and unequivocal manner and prevent possible access to outsiders or persons anyhow not authorized to enter this area. Should any components or equipment accidentally fall from a substantial height when loading or unloading, this can result in immediate danger.

## CHAPTER 6: INSTALLATION

Record of modifications

Revision	Executor	Date	Description of modification

## 6 INSTALLATION

### 6.1 INTRODUCTION

The operations described in this chapter are of particular importance as they explain the installation and disassembly procedures of the machine. Experience has shown that accidents (fortunately rare) have never occurred during normal operation, but have always occurred during the installation process, and even more during the disassembly process of the machine. During these operations there are utensils and equipment, material and components of the machine which have not yet been permanently fixed, and they simply rest on the horizontal level of the working area and the machine itself can seem to be stable even though it is not yet completely mounted and anchored to the structure in question.

#### **ATTENTION:**

Before starting to implement the operations mentioned below, the persons who are designated to perform the work must have read and more importantly UNDERSTOOD the instructions in this manual.

The operations of loading/unloading, handling, transporting, assembling, using and disassembling the machine must be carried out by personnel who is trained appropriately and effectively and directly monitored by the site manager (SUPERVISOR) who has to ensure that the above-mentioned operations are carried out up to standard, in compliance with all the safety conditions and meticulously adhering to the instructions found within this instruction manual.

#### **DANGER:**

Failing to evaluate the installation conditions is the greatest and most common cause of accidents, often with a fatal outcome.

#### **ATTENTION:**

During the installation process, the use of the machine must be denied to all unauthorized personnel and must remain the exclusive responsibility of the Qualified Person designated to carry out this process.

All the components constituting the machine must be meticulously checked and examined before every new installation, to remove and unequivocally mark any parts which may be broken, deformed, cracked, corroded or affected by other factors, and no longer ensure sufficient reliability. The members of staff, qualified and trained in carrying out the operations of assembling, checking, handling, using and disassembling the machine, must use suitable equipment, according to the particular risks they may be exposed to and personal protection equipment such as, work gloves, hard hat, safety footwear with non-slip soles and reinforced metal as well as a toe-cap, safety harnesses with shoulder straps having hook components, and high visibility jacket, etc.

The following functions must be constantly monitored during the assembly operations:

- the exact positioning of the structures and components constituting the machine, in accordance with the heights and indications shown in the installation design, and particularly in conformity with the horizontal and vertical measurements or distances provided in the design itself
- proper implementation of the machine's anchor devices, in conformity with the executive layouts and particular instructions provided by the manufacturer
- functionality and efficiency of the mechanical, electromechanical, and electrical safety devices, specifically intended for assembly, use and disassembly of the machine.

**ATTENTION:**

Always ensure that during the installation process the wind speed does not exceed 28 MPH.

**ATTENTION:**

Meticulously adhere to the configurations and layouts provided and permitted in this instruction manual. Layouts and configurations which are different from those provided are allowed if specific authorization is given by BETA MAX's technical office. BETA MAX disclaims all responsibility for non-compliance or more for contributory negligence in respect to the restrictions given.

## 6.2 INSTALLATION DATA SHEET

The data sheet contains the weight of the machine and the heights relative to the installation of the machine in question.

The data sheet must be completed by the site manager.

The data sheet duly photocopied and signed must be handed over to the operator designated to carry out the machine's assembly. This document is to be the reference document for the installation process.

See appendix A in this manual.

**DANGER:**

Non-conformity with the indications given in the assembly data sheet can damage the machine and endanger the operators responsible for its use. BETA MAX disclaims all responsibility deriving from non-compliance with that which is specified in the assembly data sheet.

## 6.3 INSTALLATION PROCEDURE

This paragraph is intended to guide the operator during the machine installation indicating the different execution phases order with relative detailed paragraphs described for each operation. To perform a correct installation, proceed as follows:

1. check and verify all the machine's components
2. prepare the machine's installation site
3. position the machine at the site
4. prepare all the electric power connections of the machine
5. rotate the mode selector switch onboard control panel to the PERSON/TP position to enable the machine to function through the loading unit directly
6. install the mast, anchorages, and accessories
7. install the braking pads
8. install the floor's access doors
9. install the stop cams on the mast by adjusting their position to allow the stop at the ground and landing floor levels and permit to open the ramp correctly on the floorboard
10. attach the calling board from the floors (not applicable for Transport Platforms) beginning from the base control panel
  - a. In case the calling system from the floors is not present, insert the 6-pole connector on its place at the base control panel

### **ATTENTION:**

**Remember always to install the terminal connector at the last calling board at the floors to close the electric circuit of the calling boards if not, the machine shall never get to function properly.**

11. verify all the security and safety systems present on the machine, on the ground enclosure and on the access doors at the floors

***At this point, the machine is ready for normal operations.***

## 6.4 TEST AND VERIFICATION DATA SHEET OF THE MACHINE'S COMPONENTS

The test data sheet, attached to the machine's use and maintenance instruction manual, is the original, and a double copy of it must be completed by the person who is adequately trained to carry out the installation operations. It is obligatory to state the name and address of the installation technician in this copy. A copy of the above-mentioned data sheet, with all sections completed correctly, must be handed over to the site manager where the machine is to be installed and to the owner of the machine.

The data sheet in question must be duly completed and signed before an installation process is carried out or, alternatively, every time the machine is returned after being installed in a construction site and therefore, kept as proof after having checked the functionality of the machine.

See appendix B in this manual.

**NOTE:**

Verifying and testing all the material listed in the data sheet will allow the machine to be installed correctly.

## 6.5 FOUNDATION FOR POSITIONING THE MACHINE

To position the machine safely and correctly, a full understanding of all structural drawings of the building will be needed, with special attention at the foundation where the machine is to be positioned. It will be necessary to exclude any presence of underground drainage, duct or any other cavity that could cause the subsiding of the machine's base frame during its working period. It is extremely important to evaluate ground consistency to ensure that it will withstand the pressure exerted. In case of support feet only would not give enough guaranties of resistance, planking will have to be placed under each support foot or create special structures to share in satisfactory values the surface pressure. This operation is of fundamental importance because in case of supports subsiding, it would cause the verticality losing of the mast and the anchors downwards strain. That condition would be very dangerous for machine stability. The operator is asked to verify the specific aspect and operate in agreement with all safety measures reported in this manual.

Refer to the machine's table of weights to check the actual ground pressure for every installation and adopt the related foundation criteria.

When assembly is carried out with a free-standing mast and the base unit is anchored to the ground, it is fundamental to create an adequate concrete slab or use a metal plate; in both cases, the minimum measurements must be 96 in x 96 in.

The concrete slab must be made in accordance with the following instructions:

- the concrete must be perfectly vibrated
- the finished surface must be perfectly level and smooth
- the foundations can be made in either one of the following ways, depending on the desired level of the finished surface of the concrete slab in respect to the ground.

To make the foundation you must take into consideration all exerted loads with the machine fully loaded working and considering the total height of the installation as follow:

For all configurations the value  $N_c$  is identified by the expression below:

$$N_c = \frac{H}{1,4577} \quad \text{value rounded down} \\ \text{(H mast total height in meters)}$$

### ***MACHINES EQUIPPED WITH BASE FRAME SUPPORT FEET***

For those machines the maximum load  $F$  exerted on each foot with the machine operating with full load is derivable from following formula:

$$F = 3500 + 50 \times N_c \text{ (daN)} \quad - \quad \text{For working heights up to 65 ft} \\ F_1 = F/2 \quad \text{Force acting on a single foot near mast}$$

### ***MACHINES WITH BASE FRAME LAYING ON THE GROUND***

In the case of installations with working heights over 65 ft and below 400 ft the base frame must be lowered onto the ground. In this condition (without support feet) it can be considered a pressure to the ground derivable from following formula:

$$P = 2100 + 40 \times N_c \text{ (daN/m}^2\text{)}$$

#### 6.5.1 Concrete slab resting on the ground

The concrete slab made to rest on the ground has the following advantages and disadvantages:

- advantage: it is not required to be drained
- disadvantage: high threshold

#### 6.5.2 Concrete slab at the same level of the ground

The concrete slab at the same level of the ground has the following advantages and disadvantages:

- advantage: it is not required to be drained
- disadvantage: the loading units have a high threshold

The concrete slab at the same level of the ground is the most common type of foundation. Normally, a ramp is made of wood or steel to reach the threshold level of the platform.

#### 6.5.3 Concrete slab below ground level

The concrete slab below ground level has the following advantages and disadvantages:

- advantage: no height threshold between the ground level and the loading unit's
- disadvantage: corrosion; if water remains in the foundations and it is not perfectly drained

This alternative requires the ground to be drained carefully. It is very important that the foundation remains insulated from the surrounding ground, otherwise you must prevent the surrounding ground from freezing.

#### 6.5.4 Boarding structure support for surfaces which are not so solid

If the machine must be installed on a surface which is not so solid and therefore cannot guarantee to resist the actual pressure exerted by each supporting foot, it is recommended to create a boarding structure as reinforcement for the force to be distributed correctly.

To distribute the pressure on the ground in an optimal way, we can say that the linear measurements of the machine's support must be amplified by following a total angle of about 90°. This is created by inserting several planks under the support itself and these must have a width which increases slightly as you go along, until reaching the condition shown in figure 6.1. The height of the boarding structure which is to be created is therefore directly proportional to the increase in the base unit support, which must be attained and can be calculated by using the following formula:

$$H = \frac{A - a}{2} \quad A = \sqrt{\frac{F \times 10}{P}}$$

F = pressure exerted on the ground (daN);

P = pressure bearable by the supporting surface (MPa)–(1MPa=10bar=10daN/cm<sup>2</sup>);

A = total width of the supporting board on the ground (cm);

a = width of the machine's supporting foot (cm);

H = height of the boarding structure which is to be made (cm).

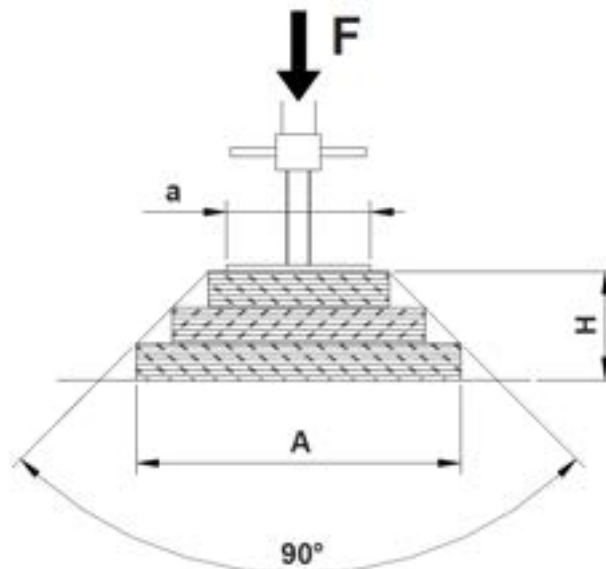

Figure 6.1

## 6.6 DISTANCE OF THE MACHINE FROM OBSTACLES

When choosing installation position, it is necessary to check for the presence of any obstacles anywhere near the machine elevation path and measure their minimum distance from the nearest part of the machine itself.

Normally the machine is installed at a minimum distance of **18 inches** from possible obstacles when installed as a TRANSPORT PLATFORM (REFERENCE ANSI/SAIA A92.10) and **0.75 to 2.5 inches** from possible obstacles when installed as a MATERIAL HOIST (REFERENCE A10.5). In case this is not possible, it is necessary to protect people from shearing risk (persons Trapping or Crushing hazard) by installing safeguarding arrangements / safety protections as described below. By obstacle it means any object which is protruding towards the machine elevation path to a distance less than 18 in from it (trees, streetlamps, suspended cables, terraces floor slabs, steel beams, etc.).

### 6.6.1 Shearing risk for people moving on structures adjacent to the machine (TRANSPORT PLATFORM ONLY)

Openings of buildings or structures (e.g., windows or balconies) giving onto the machine elevation path must always be protected to avoid people accidentally fall onto the machine path. In accordance with the various countries' applicable legislation, when the machine is over 18 in from possible obstacles these protections must be between 42 in and 47.25 in high.

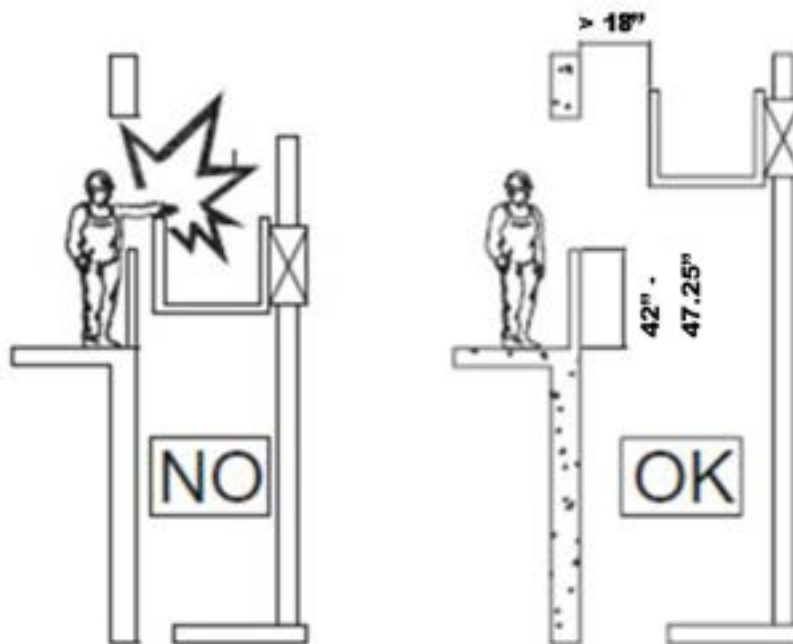

Figure 6.2

### 6.6.2 Shearing risk for people transported on the machine (TRANSPORT PLATFORM ONLY)

When the machine is used to transport people, shearing risk is extended also to people on board. The standard machine is supplied complete with side safety guards 43.3 in high, which are sufficient to guarantee adequate protection for people on board machines in the presence of obstacles at distances over 18 in from the machine itself and its path.

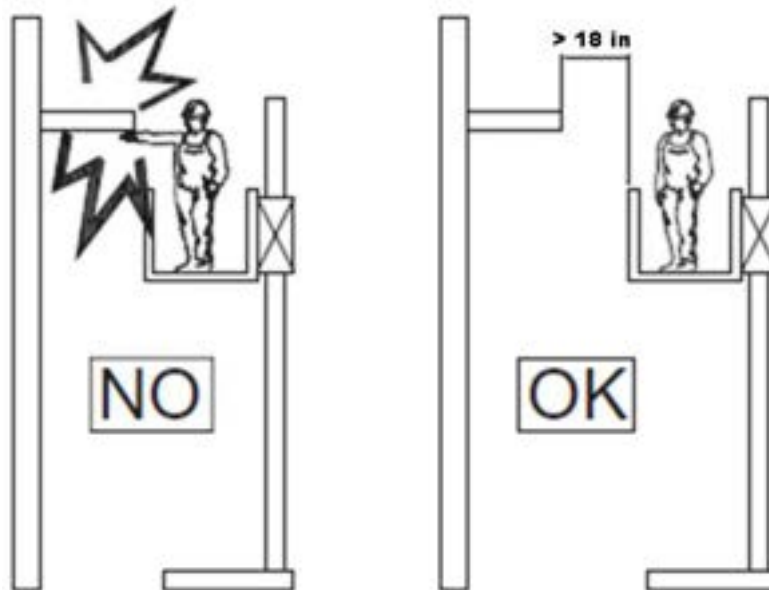

Figure 6.3

### 6.6.3 Shearing risk for people moving on structures adjacent to the machine (MATERIAL ONLY)

Openings of buildings or structures (e.g., windows or balconies) giving onto the machine elevation path must always be protected against shearing risk and to avoid that people cannot accidentally fall into the machine path. In accordance with the various countries' applicable legislation, when the machine is 0.75" – 2.5" from possible obstacles these protections must be extended the full height between floors, or a minimum of 10 feet, whichever is less at each floor landing. Landing door openings must be a minimum height of 6 ft. 6 in.

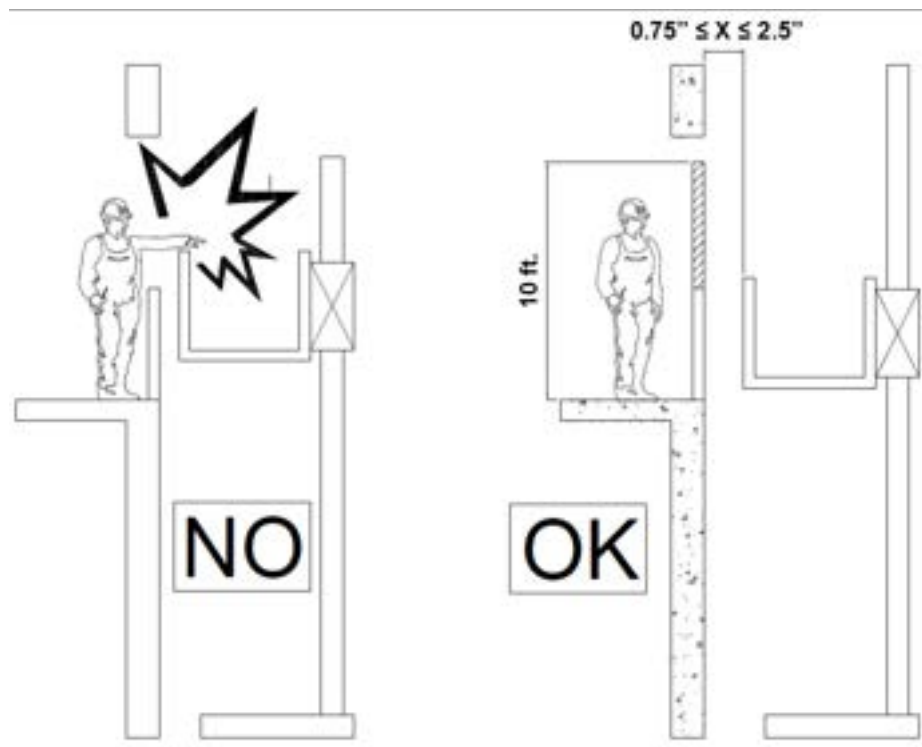

Figure 6.4

## 6.7 MOUNTING INSTRUCTIONS

The machine must always be used in accordance with standards of operation and safety regulations in force in the country where it is to be used. The following rules are therefore only indicative and must be implemented accordingly to each specific case. For the assembly and use of the machine, carry out all the operations described below, in succession.

### **ATTENTION:**

All the assembly and disassembly operations of the machine must be carried out solely by personnel who is authorized and trained beforehand on its specific operation and use.

## 6.8 MOUNTING THE PRE-ASSEMBLED MACHINE

To mount the pre-assembled machine, proceed as described below:

- close off the area where the un/loading and assembly operations of the machine are to be carried out, in a clear and unequivocal manner, and enclose its perimeter in an effective manner, to prevent possible access to outsiders or persons anyhow not authorized. Bear in mind that the subsequent operations will be implemented at a substantial height from the ground, and should any component or equipment accidentally fall, it can result in immediate and serious danger
- ensure that the floor on which the machine is to be placed is horizontal and sufficiently stable, in accordance with what is stipulated in the chapter within this use and maintenance instruction manual, pertaining to the description of the foundation to position the machine.
- unload the machine from the transport vehicle using a crane or lift truck which has an appropriate lifting system. If using a lift truck, the machine can be placed on the lower part of the base unit. If using a crane, strap the machine from the base unit with belts which have an adequate load capacity. In both cases the machine must be perfectly balanced
- for no reason whatsoever should anyone pass or stay under suspended loads during this stage and the other un/loading stages, which will be described further on. If using a crane, only the operator will be authorized to handle the suspended load to facilitate its correct positioning. If using a lift truck, only the driver of the same truck will be authorized to carry out the operations; all other persons will have to stay at a distance, where they cannot be affected if the load accidentally tips over and they must remain there until the operation is carried out completely. It is necessary for individual protection gear to be worn during these operations
- proceed to unload the remaining material and accessories constituting the machine and distribute them in an orderly and safe manner close to the machine itself. Ensure that the material placed on the ground cannot, in any way, accidentally move, constitutes a danger to persons working nearby and for no reason whatsoever, subsequently interfere with the machine's path
- if part of the material has been placed inside the machine's loading unit (to optimize space allocation, remove the material from the unit and place it on the ground before carrying out any other operation pertaining to the installation
- ensure that no damage has been caused to the equipment during transportation or during the loading/unloading operations

### **DANGER:**

Close off the area where the loading/unloading and assembly operations of the machine are carried out, in a clear manner and prevent access to outsiders or persons who are not authorized to enter this area. Should any components or equipment accidentally fall from a substantial height during the assembly process, can result in immediate and danger.

### 6.8.1 Positioning the machine on the ground

To position the machine on the ground, proceed as described below:

- check the condition of the flooring it is to rest on this must be as uniform and level as possible and clear of any obstacle. The machine must be installed in such a way for the base unit to be perfectly level, reducing the overall inclination to an angle smaller than 1°. Check its consistency and suitability for the machine's load and adopt all measures indicated in Section 6.5 "Foundation for positioning the machine" in this use and maintenance manual
- visually inspect the machine's path which is to be used and ensure that it is free from power lines, telephone lines, or cables of streetlights etc., or any protruding parts or parts with rough edges jutting out of the building or structure in question; moreover, ensure that there are no structures which may be eventually modified and interfere with the machine's path
- place the machine in the exact place where it should be installed, carefully verifying the distance between the loading unit and the part which protrudes the most from the building or structure in question; the loading unit must pass through this distance safely, in its every possible condition
- **this distance must not be less than 18 in. if installing the unit as a Transport Platform as indicated in ANSI A92.10 as shown in figure 6.5 (if using landing doors for a transport platform supplied by BETA MAX set the unit 24 inches from the building for the door to function properly) or if installing the unit as a Material Hoist is not greater than 2.5 in. as shown in figure 6.6 to ensure the loading unit passes through with no difficulty and no risk of collision**
- when positioning the machine, you must measure the distance from both extreme ends of the loading unit in respect to the structure in question, to be sure that there is parallelism between the machine and the facade. The difference between the measurements taken from the loading unit's extreme ends must not, in any case, exceed 3/8 in.

**Transport Platform mode**

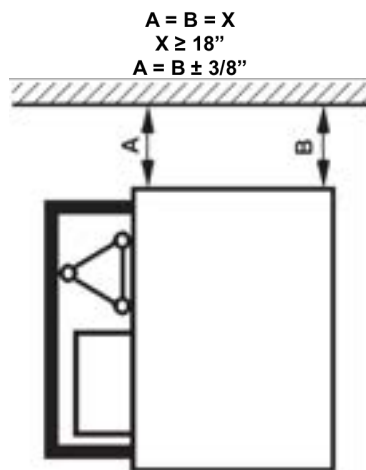

Figure 6.5

**Material Hoist mode**

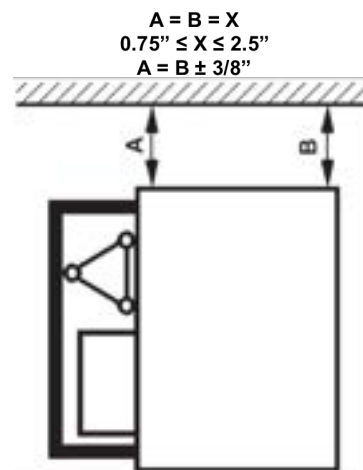

Figure 6.6

- install a mast above the one on the base, after having verified that both support surfaces are perfectly clean and free from any residue; carefully tighten the fastening bolts to 105Nm (78 ft-lbs). Ensure that the two extreme ends of the masts which come into contact fit perfectly with no ridges between the main vertical supports or between the racks, as shown in figure (no residual air must remain in between the surfaces when they come into contact). If the connection between two masts does not seem to be perfect or does not comply with the instructions provided earlier on, contact BETA MAX Technical Support immediately

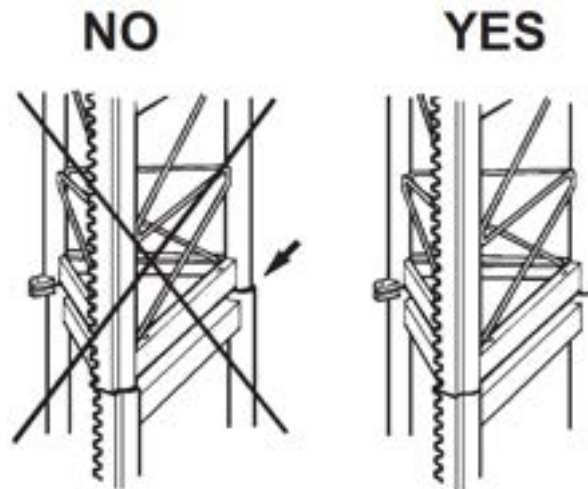

Figure 6.7

- with the use of a level (1), and by using two sides of the rack as a reference plane, check the mast's verticality. Carry out this procedure on the mast as soon as it is installed, bearing in mind that the higher this verification is carried out, the more the leveling will be correct, since the difference generated by the angle of inclination in respect to the ground will be amplified
- verify the leveling of the base support adjusting if needed

### **ATTENTION:**

The leveling of the mast is a very important process. The mast must be positioned in conditions of absolute vertical inclinations that exceed 1 degree are not permitted.

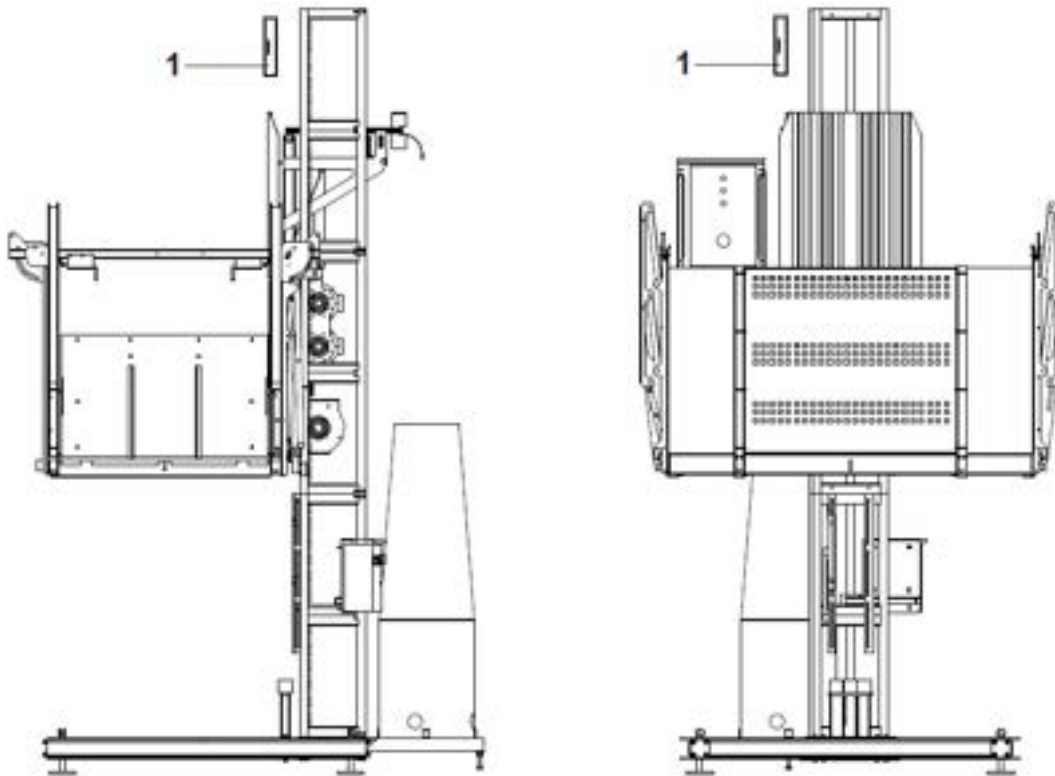

Figure 6.8

### 6.8.2 Preparing the machine's functionality before connecting the power supply

Before connecting the power supply, to prepare the machine for this, proceed as follows:

- ensure that the braking cams are used to stop when going down and for the lower overtravel, are present and positioned correctly
- ensure that the hatch of the base and onboard electrical control panel is closed properly
- ensure that the main power switch of the base and onboard control panel is in the “OFF” positions
- set the selector on the onboard control panel, in “TP” position
- ensure that appropriate closure caps are fitted on all the other multi-pin connectors which are not in use
- verify the integrity of the electric power and control cable.

### 6.8.3 Connecting the power supply

Once the machine is set in place, proceed to connect it to the power supply as described below:

- The installer is responsible for connecting the power supply and he must use a type of electric cable which is suitable for the relative installation. In any case, when preparing the power line, you must be particularly careful in choosing a path for the electric cable, making sure that this cannot be immersed in water, trampled on by persons or any type of vehicles even if they have rubber wheels, operating in the construction site. If the power line is to be elevated, this must be marked with proper signs and placed high enough to ensure absolute safety for all that passes below. Proper signs have to be set in place even if the power line is buried underground, to prevent risks caused by excavation or earth moving machinery
- The electrical load of the unit is located at the hoist basket which travels up and down the mast tower and not at the base of the unit. **When sizing for the correct cable size to supply power to the hoist; the required load, distance from the supply power to the base of the unit, and the length of the trailing cable (not the mast height) needs to be calculated to minimize voltage drop to the unit. (MINIMUM SIZE SUPPLY CABLE IS 4 CONDUCTORS OF 4AWG)**
- connect the device to the power line, which is equipped with an earth connection, a magnetothermal switch with appropriate power to protect the power line and a differential circuit breaker switch
- check that the supply voltage corresponds to that of the electric motors and to the data shown on the machine's identification plate. Ensure the phasing of the supply voltage is correct, correct the phasing at the base of the unit at the location where the supply power is connected. Never change the phasing between the ground control box and onboard control box
- implement the machine's earth and lightning protection system with the use of the special bolt appropriately marked on the base unit. Ensure that the earth connection is implemented with a conductor having a cross-section which is not less than that of the relative power line conductor.

#### 6.8.4 The first handling process of the machine

Once the electrical connection of the machine is implemented, it is good practice to move on to handling the loading unit to verify its functionality.

Proceed as described below for the handling process of the machine:

- the electrical control panel installed onboard is accessible when the cabin is grounded, and it is locked with a key which is to be kept exclusively by the system maintenance technician. A copy of the wiring diagram must be kept near the electrical control panel, and this must include the safety circuits (this diagram is also found in the relative chapter of this manual). Upon each installation of the machine, there must be a free space left in front of the electrical base control panel, of at least 24 in. to facilitate opening the hatch to carry out any inspections needed
- place the electric cable in such a way to ensure it goes up and down smoothly
- before supplying electrical power, check the position and correct functionality of the safety main switches found inside the electrical control panel
- check and if need be, set the safety lock switches to the “OFF” position
- check and if need be, turn the relevant switch to the “TP” position
- check that the emergency push button of the control panel is pressed
- insert the power plug in the proper socket on the base control panel, blocking it with the external ring found on the socket
- position both safety lock switches in the “ON” position

### **DANGER:**

The stages described below must be carried out with the operator on the ground and the cabin completely unloaded and free from any kind of material.

- rotate the emergency push button, found on the hatch of the onboard control panel, in the same direction as the arrows
- check the state of the blue SINGLE PHASE MODE light signal (if present) on the electrical control panel onboard the machine and verify if:
  1. the warning light will be off if connected to three phase power in the correct rotation. The electrical connection has been carried out correctly.
  2. the warning light remains continuously lit if connected to single phase power. If connected to three phase power the electrical connection has not been carried out correctly, the power supply phase sequence is incorrect, or a failure has resulted in the loss of one or more phases.

The machine will be ready for the handling process.

### **DANGER:**

Before proceeding with the handling process of the machine, verify and ensure that all the stop position and safety devices function properly.

- press and release the emergency pushbuttons found on the control panels and of on the keyboards, open and close the access doors of the loading unit and of the base enclosure, open and close the folding platform used to mount the anchors; with each one of these operations, you must hear the main contactor go on and off inside the electrical control panel onboard the loading unit
- try and press the UP pushbutton on the control keyboard, while implementing each one of the following one at a time, pressing the emergency push button, keeping an access door of the loading unit open, keeping the anchor assembly platform open

**DANGER:**

In each one of these conditions, the machine must not move in any way, otherwise, shut it down and immediately contact BETA MAX technical support.

- restore all the machine's operating conditions and press the UP pushbutton on the control keyboard for a short while, the cabin will move in this direction stopping when the pushbutton is released.
- implement the same operation but press the DOWN push button; ensure that the machine stops correctly on the downward end-of-travel pad.
- implement this operation two or three times, checking the constant behavior of the machine.
- At this point, if the checks have been positive, start the assembly stage.

**DANGER:**

The operations described below are intrinsically more dangerous, usually having substantial heights in respect to the ground; extreme caution is recommended in carrying out each operation and unconditional conformity with all the rules and warnings stipulated below.

To carry out the installation process of the machine, it is obligatory to wear all the individual protection gear, as expected; all procedures must be strictly complied with and also in the same chronological order as given in this manual; and solely persons who have been properly trained and specifically authorized must carry out operations. The safety of the persons who carry out operations may be seriously put at risk by the total or partial non-compliance with the instructions given until now in respect to the correct preparation of the machine and the site where it is installed.

**DANGER:**

Adhere to all the indications, in a meticulous manner, pertaining to the weights and measurements of the loads stipulated in Chapter 3, Section 3.5.6 "Dimensions and capacities" and unconditionally comply with all the rules and warnings stipulated below.

During the assembly stage only two operators are allowed on the machine and a maximum load of **800 lbs**. In the absence of the hoist used for mounting the masts, two persons are recommended to be present to handle the masts themselves in an easier manner, however, in any case it is **absolutely forbidden for more than two persons to be onboard**, irrespective of the operating conditions. The material loaded onto the machine must be absolutely contained within its perimeter, ensuring that no component protrudes beyond this. During the handling process of the machine, persons and material must be within its perimeter, for no reason whatsoever, should things or persons be dangling or located outside the loading unit, loading ramps etc. The operator who maneuvers the assembly keyboard, prior to handling the machine, must ensure that the other person, if present, is located inside the cabin, in safe conditions, and must keep this person informed, at all times, about the maneuver he intends to implement. Once the desired position is reached, to carry out the particular operation, the emergency pushbutton must be pressed, and must remain like this till the subsequent, optional movement. The above-mentioned procedure must be followed for every move.

**DANGER:**

An approximate assessment of the installation conditions is the greatest and most common cause of accidents.

**DANGER:**

Independently from the number of mast sections you carry with you during the erection, you must follow specific assembling instructions concerning anchorages. The consecutive assembling of mast sections, without having fixed the anchorage as indicated in the manual is absolutely forbidden.

**ATTENTION:**

Always make sure the wind speed during installation is less than 28mph.

**ATTENTION:**

The load must be evenly distributed and as close to the vertical mast as possible. The material must be transported in such a way as to avert the risk of tilting or falling and should be laid so that there is no danger of tripping. Never stack the material near the edge of the loading unit.

## 6.9 MOUNTING THE MAST AND THE FIRST WALL ANCHOR

The instructions provided below pertain to the installation of the first wall anchor and the assembly of the mast, assuming that the first component of the vertical mast has already been installed on that of the base unit, for the first leveling procedure of the machine.

Bear in mind that to prevent it from tipping over, the first wall anchor must be implemented at a maximum height of 24.60 ft from the ground.

### **DANGER:**

To install a particular anchor system or in any case one that is not considered in this instruction manual, it is always necessary to contact BETA MAX Technical Support.

To mount the components constituting the mast, proceed as described below:

- mast sections in a maximum quantity of five pieces, with relevant bolts, washers, fastening nuts and all components needed to install the anchor have to be loaded on the loading unit. When positioning the masts onto the loading unit, be careful to place them upright with the part for the tapered couplings on the lower part, in an orderly manner and close to the lifting unit
- load all the accessories needed for mounting the first anchor, into the machine
- drive the cabin up to the limit of the mounted mast (two safety hooks are provided to prevent it from dropping down, in case of an incorrect maneuver being implemented)

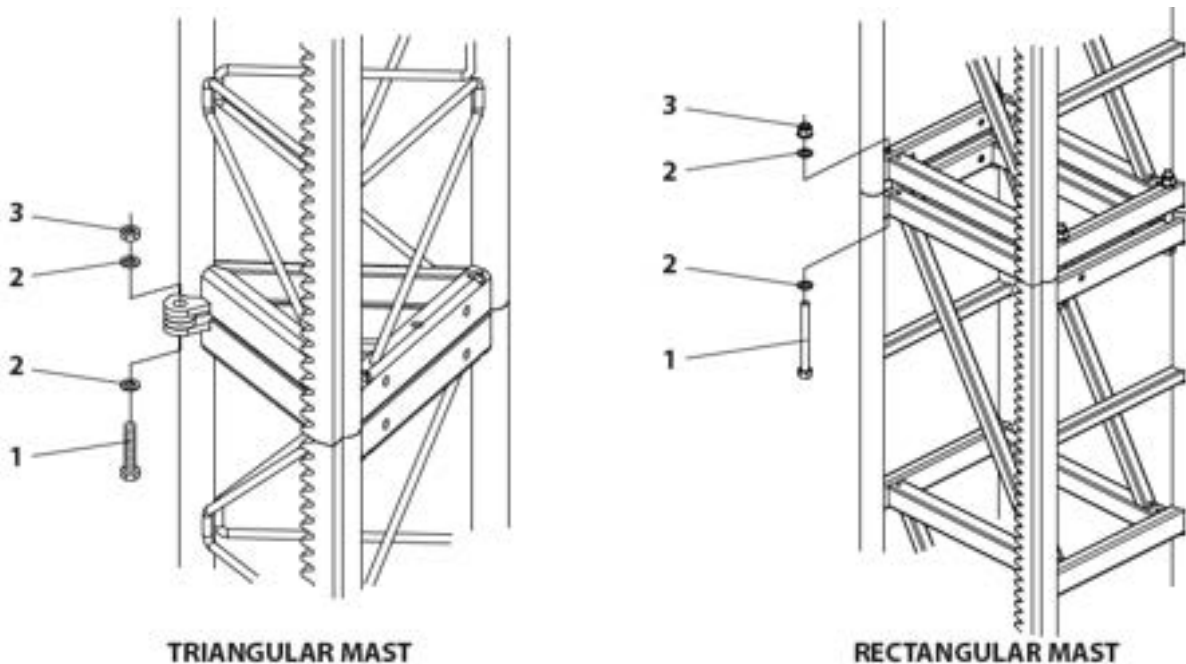

Figure 6.9

### **ATTENTION:**

For mast section fixing you can use only:

- Bolts **(1)** M16x160 and M16x70 UNI 5737 with a minimum resistance of 8.8;
- Washers **(2)** 17x30x3 UNI 6592;
- Nut **(3)** M16 UNI 5588.

- you are advised to insert the bolts between two masts starting from the lower part and moving upwards as shown in figure so that, in an unfortunate instance of a nut becoming loose, the bolt can fall, making it clear that it is missing during a subsequent inspection. It is certainly more evident and visible, even at a glance, if the entire bolt is missing as opposed to only the nut
- when mounting a mast on top of another, take care to ensure that the two support surfaces are perfectly clean and free from any residue; carefully tighten the fastening bolts to 80Nm (59 ft-lbs). Ensure that the two extreme ends of the masts which come into contact fit perfectly with no ridges between the main vertical supports or between the racks, (no residual air must remain in between the surfaces when they come into contact). If the connection between two masts does not seem to be perfect or does not comply with the indications provided earlier on, shutdown the machine and contact BETA MAX Technical Support immediately
- before handling the machine, ensure that the masts are perfectly mounted and tightened
- regardless, if the assembly or disassembly process is being carried out on the machine, Driving the cabin on a mast which is either partially tightened or not tightened at all, could cause the component to detach itself immediately, resulting in the loading unit dropping down. As yet, systems or means to prevent the operator from making such a serious mistake are not known

### **DANGER:**

**Driving the machine on a mast that has a component which is either partially tightened or not tightened at all, could cause the component to drop down immediately. A SIMILAR ACCIDENT WOULD CERTAINLY CAUSE THE DEATH OF THE OPERATORS ONBOARD THE MACHINE.**

- before moving on to another operation, terminate the operation being carried out; never carry out two or more operations at the same time, when delegating tasks to others always verify the result

- Before mounting the wall anchor, check verticality of the mast with the use of a spirit level and by using two sides of the rack as a reference plane; check the mast's verticality, as described earlier on. Carry out this procedure on the last mast installed, bearing in mind that the higher this verification is carried out, all the more the leveling will be correct, since the difference generated by the angle of inclination in respect to the ground will be amplified.
- verify the leveling of the base support adjusting if needed.

**DANGER:**

The leveling of the machine and the mast is a very important process. The mast must be positioned in conditions of absolute verticality; inclinations that exceed 1 degree are not permitted.

- at this point, implement the wall anchor while referring to the instructions given in the next paragraph.

**DANGER:**

It is necessary for personal protection equipment to be worn during these operations, such as hard hats, gloves, safety shoes with toecaps, etc.

**DANGER:**

An approximate assessment of the installation conditions is the greatest and most common cause of accidents, often with a fatal outcome.

**DANGER:**

Never attach the safety harness to the vertical mast.

## 6.10 MOUNTING THE ANCHORS

The operator must be certain of the forces exerted by the anchor system onto the structure in question and verify that the latter is suitable to withstand them; he must make the right choice when deciding upon the mounting components in accordance with the building structure. If the machine is anchored to traditional scaffolding, the layout must be considered appropriate. Any layout of anchors which is not given in this manual may only be implemented if it has been brought to the attention of and explicit authorization is given by BETA MAX. The implementation of the anchors must be carried out solely by means of the proper mounting platform, or by using methods of equal efficacy and safety, such as hydraulic baskets, traditional scaffolding towers, balconies which the building may have etc. However, personal protection equipment must be utilized anyway, such as a safety harness, hard hat, safety shoes and gloves. It is absolutely prohibited to lean over or operate from outside the platform used for mounting the anchors or the loading unit; any operation must be carried out from inside the structures mentioned earlier on, or by utilizing means which have similar safety features. It is also absolutely prohibited to climb onto and even more to operate from the vertical mast or any other protruding part of the machine, BETA MAX disclaims all responsibility in the instance of operating in conditions which are not specifically authorized, or more, in conditions which are specifically prohibited.

BETA MAX also disclaims all responsibility for causes due to the implementation of particular anchor systems which are not defined nor authorized beforehand by the manufacturer. BETA MAX also disclaims all responsibility for anchor systems which are not implemented up to standard even if specifically allowed by the manufacturer; this makes it an obligation to contact the Technical Support every time a particular installation is necessary.

**IMPORTANT:** The supervisor has the explicit task of supervising and giving adequate instructions on good practice by providing safety procedures for the implementation of such work, ensuring that individual protection gear is used and that the work is carried out in authorized places, supervising the quality of work, for example, ensuring that drills with adequate diameters are used, the holes are of the right depth, that bolts and clamps are tightened in accordance with established torque values etc.

### **DANGER:**

Not performing a full assessment of the installation conditions is the greatest and most common cause of accidents.

To mount the anchors, proceed as described below:

- ensure that the wall onto which the anchors are to be mounted can sustain the intended horizontal forces in order to sustain the machine (refer to Chapter 4, Section 4.2.6 *“Forces onto the wall anchor system”* in this manual);
- choose the most suitable type of fasteners for the type of building structure present; take care in ensuring that the fasteners used are of suitable measurements to sustain the forces exerted (refer to Chapter 4, Section 4.2.6 *“Forces onto the wall anchor system”* in this manual)

- raise the cabin to the intended height (normally 5 ft below the line where the anchor will be mounted) and press the emergency push button. Bear in mind that it is obligatory for the operator/s to be within the perimeter of the mounting platform during the handling process of the machine. Solely one operator is allowed on the anchor assembly platform
- fasten the safety harness to the proper bracket and lower the folding platform by releasing the locking device
- step onto the folding platform while keeping the safety belt on and ensuring it is fastened to the proper bracket

### DANGER:

**Bear in mind that only one person can work on the anchor assembly platform, and it is absolutely prohibited to pile up material on this. All material must be left on the loading unit and be passed, one at a time, by the operator who is on the loading unit. It is only permissible to keep tools on the mounting platform, which are strictly necessary, such as the drill, hammer, wrenches, etc.**

- for machines using triangular mast install the mast bracket (1) with the proper nut and bolts
- install the joint bar (2) between the mast bracket and the rear part of the mast, fixing it by perpendicular clamps
- install the two anchor extension bars (3) and (4), one perpendicular to the wall itself, the other inclined to about 30° towards the rear part of the mast. Ensure the holes are drilled properly and the supporting feet have a hold (5) and place the perpendicular clamps between the anchor extension and the vertical rods of the mast and the adjustable clamps between the two extensions
- apply the toggle bolts and tighten everything, including the clamps
- apply the diagonal bar (6) between the anchor extensions, using the relative adjustable clamps

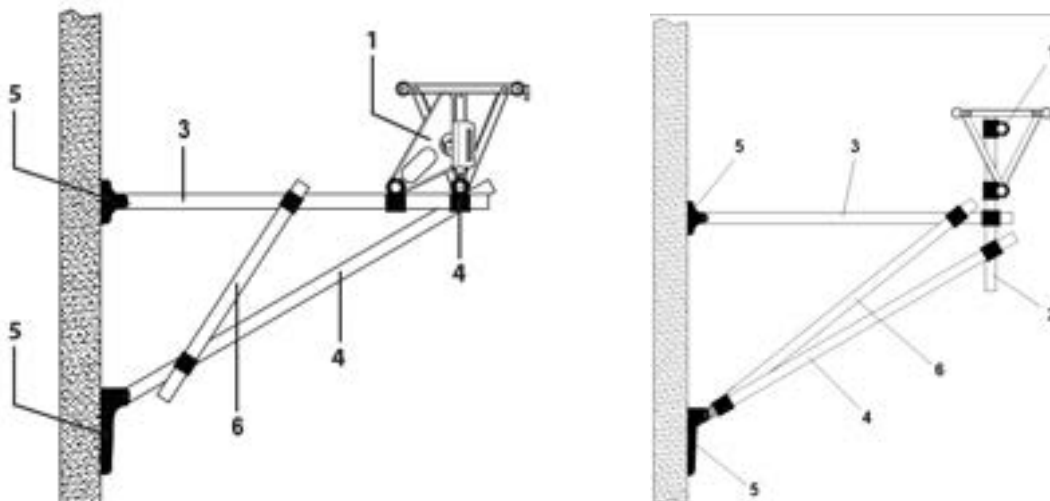
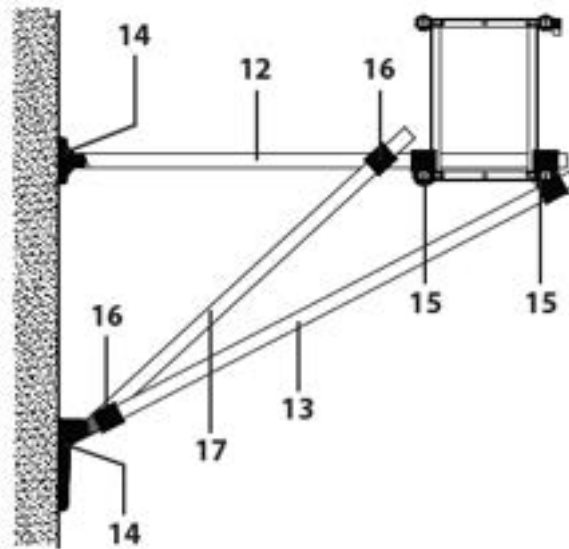

Figure 6.10

- For machines with rectangular mast, install the two anchor extension tubes (12) and (13), one perpendicular to the wall, the other inclined to 30 degrees towards the rear part of the mast. Ensure the holes, if necessary, are drilled properly and the supporting feet (14) have a perfect hold. Place the clamp (15) between the anchor extension and the vertical rod of the mast. Use an adjustable clamp (16) between the extensions (12) and (13) and the reinforced tube (17).



**ANCHOR FOR RECTANGULAR MAST**

- the anchor extensions must not be inclined more than 5° in respect to their horizontal position: ensure that the feet of the extensions are in perfect contact with the wall; if an anchor bolt seems to be even partially out, carry out its procedure again; ensure that all the bolts and clamps are tightened correctly and effectively.
- with the use of a level, check the verticality of the mast and if necessary, loosen only the components relative to the correction and implement the necessary adjustment regarding the verticality. Once this is obtained, carefully tighten, once again, all the parts which were previously loosened.
- go back on board the loading unit and raise the platform used for mounting the anchors. A safety device prevents the machine from moving if the platform is not put back into place correctly; carry out this operation while keeping the safety harness on and fastened.
- repeat the mounting operation, as described earlier on, until reaching the desired height, in any case and always refer to the layouts of the anchor systems given in this instruction manual.
- if assembly is carried out under a roof or below eaves, ensure that at the top of the mast, there is the necessary space that is established by construction regulations in force.
- apply the upward end-of-travel to the top end of the mast and verify its correct functionality (refer to the appropriate paragraph for this operation);
- install the upward overtravel pad (refer to the appropriate paragraph for this operation);

- implement a few trial movements to verify the stability of assembly and regularity of operation.

**DANGER:**

It is absolutely necessary for personal protection equipment to be worn during these operations, such as hard hats, gloves, safety shoes with toecaps etc. An approximate assessment of the installation conditions is the greatest and most common cause of accidents.

**DANGER:**

To install a particular anchor system or in any case one that is not considered in this instruction manual, it is always necessary to contact Beta Max Technical Support.

## 6.11 MOUNTING THE ELECTRIC CABLE GUIDE

The frames of the electric cable guide must be mounted simultaneously with the assembly of the masts and with the implementation of the wall anchors. In doing so, the cabin gains height whilst the installation processes are completed. Even during the machine's installation process, the electric cable must not be left loose as any swinging effect can cause it to get entangled with the machine's components or the structure in question. Every time a part of the mast is installed and reaches a length equal to the recommended interval in between the cable guide, set the frames in place immediately.

To mount the cable guide, proceed as described below, with reference to figure:

- mount the cable guide (1) on the rear rods of the vertical mast; fasten it with the appropriate clamps (2) and verify the correct alignment with the cable container. The first cable guide must be mounted at a height of 2.5m (8.25ft) (from the ground, the second at a distance of 3.5m (11.5ft) from the first one and subsequently at intervals of 6m (19.68ft), as shown in figure
- ensure that the cable puller is centered with the cable guide
- ensure that the cable guide is kept at a short distance from the machine when this is positioned to stop at a floor level

The distance to be applied between the cable guide frames as suggested earlier on is to be considered a general guideline. This distance can vary, generally reducing the distance between the frames of the cable guide, depending on the necessity and in accordance with the windiness of the area where the machine is installed.

### **DANGER:**

It is absolutely necessary for personal protection equipment to be worn during these operations, such as hard hats, gloves, safety shoes with toecaps, etc.

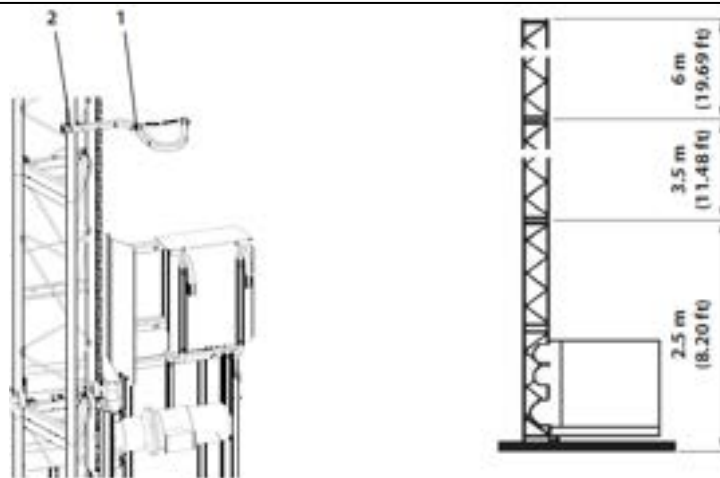

Figure 6.11

## 6.12 MOUNTING SUBSEQUENT MASTS

To mount the components constituting the mast, proceed as described below:

- not more than four components, which constitute the mast, are to be loaded onto the cabin and these are inclusive of the relative bolts, washers, fastening nuts. When positioning the masts onto the loading unit, be careful to place them upright with the part for the tapered couplings on the lower part, in an orderly manner and close to the motorized part of the lifting unit
- for the subsequent operations, proceed as described in Section 6.7, meticulously following all the instructions given in the various points
- before handling the machine, ensure that the masts are perfectly mounted and tightened. For both the assembly and disassembly operations, driving the loading unit on a mast which is either partially tightened or not tightened at all could cause the component to detach itself immediately, resulting in the loading unit dropping down. As yet, systems or means to prevent the operator from making such a serious mistake are not known

### **DANGER:**

Driving the loading unit on a mast that has a component which is either partially tightened or not tightened at all could cause the loading unit to drop down immediately. **A SIMILAR ACCIDENT WOULD CERTAINLY CAUSE THE DEATH OF THE OPERATORS ONBOARD THE MACHINE.**

### **DANGER:**

It is absolutely necessary for personal protection equipment to be worn during these operations, such as hard hats, gloves, safety shoes with toecaps, etc.

## 6.13 MOUNTING OF LANDING AND SLOWDOWN PADS

### 6.13.1 Landing pads

The base unit is supplied with the end-of-travel pad (1) and the downward overtravel pad (2) already installed, as shown in figure 6.11 and appropriately adjusted to be able to operate at the minimum height from the ground. In normal operating conditions, the downward end-of-travel pad (1) has the function of stopping the cabin at the right height from the ground and is positioned about 5.25 in) lower than the overtravel pad (2). The overtravel pad (which is also a safety device) intervenes by stopping the cabin and interrupting the power supply if the normal downward end-of-travel malfunctions or is damaged. If the overtravel pad intervenes when the normal downward end-of-travel is in good operating condition, this indicates the machine is malfunctioning. One of the most probable causes is an increase in the braking distance, due to excessive wear and tear or poor adjustment of the motor brake.

### ATTENTION:

When this occurs, before using the machine again, you must identify and remove the cause which led to the malfunction.

To regulate the stopping position of the cabin, you slide the pad accordingly on the appropriate eyelets that support the pads.

Once the masts are assembled, install the end-of-travel pad (1) and the overtravel pad (2), as shown in images below. In figure 6.13, the upward end-of-travel pad (1) must be positioned and adjusted in such a way for the cabin to stop at the desired height; position the overtravel pad (2) at about 2 in higher. Perform various maneuvers to verify the correct operation of the stop.

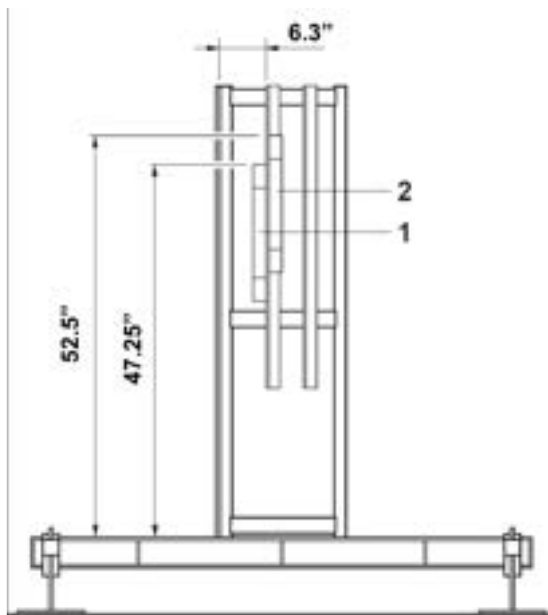

Figure 6.12

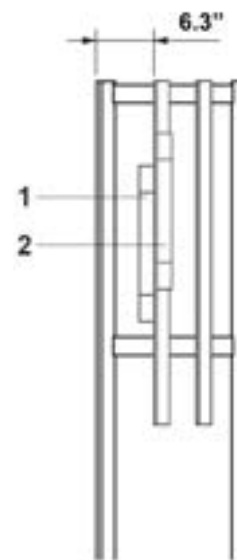

Figure 6.13

### 6.13.2 3M Terminal stop pad at 10 ft

Attach the descent terminal stop pad 10 ft above the ground as shown in figure. One support rack (1) is already installed on the base mast, corresponding to the switch on the left side of lifting gear. Install the second support rack on the second mast. Attach the stop pad (2) and verify its position against the respective switch.

Set the switch MATERIAL/TP to MATERIAL and attach the assembly keyboard to the base control panel. From the ground floor level, try a rise maneuver to reach the first upward landing pad and do the same maneuver downwards. The machine will stop at 10 ft above the ground as soon as a switch engages with a respective stop pad. To perform the descent of the last 10 ft is necessary to maintain constant pressure on the DOWN push-button (a human-controlled operation). Perform movement tests a few times to check the perfect functioning of the stop system.

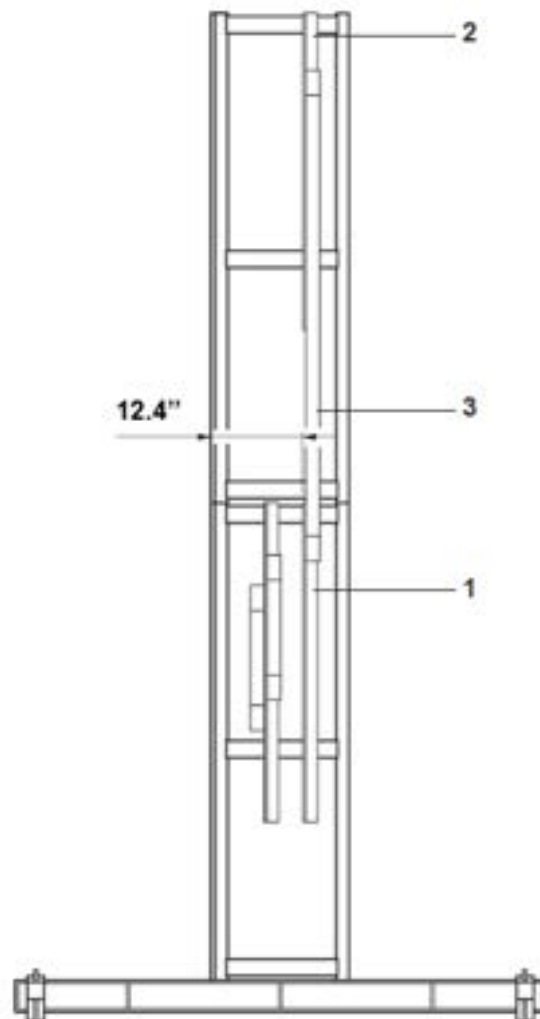

Figure 6.14

### 6.13.3 Floor level braking pads

To mount the braking pads at the various floor levels, whilst referring to figure and proceed as described below:

- set the switch MATERIALS/TP to TP position
- move the machine to the level where to install the first landing pad, stop the load unit in correspondence to the floorboard and open the unloading ramp. Mount the landing pad so as to be able to stop the loading unit at 2 in above the landing floorboard, in both directions
- line up the lower part of the braking pad (1) with the sensor (2) fix the pad by screws (3) and nuts (4) to the support's holes (5)

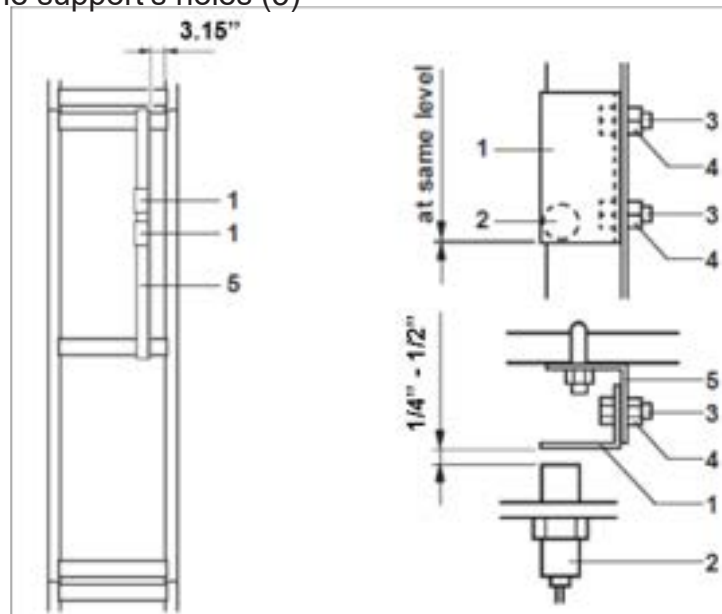

Figure 6.15

- adjust the distance between the braking pad and the sensor as shown on figure and repeat the same procedure at each landing level

### ATTENTION:

It is fundamental to adjust all braking pads properly. In case it wouldn't be placed at the prescribed distance from the sensor, they risk crushing with the sensor during the machine passage or, in case they would be mounted too far from it, the sensor wouldn't send the signal to stop the machine at the floor.

- ensure that the connections of the electrical signals of the safety devices as well as those of the floor level calling system function properly

On completion of the operations described above, the machine is ready to be used.

#### 6.13.4 Mast Presence Device

The Mast Presence Device detects the incorrect installation of mast sections and intervenes in the motion of the machine. Before operating the machine, it is necessary to check the functionality of this device.

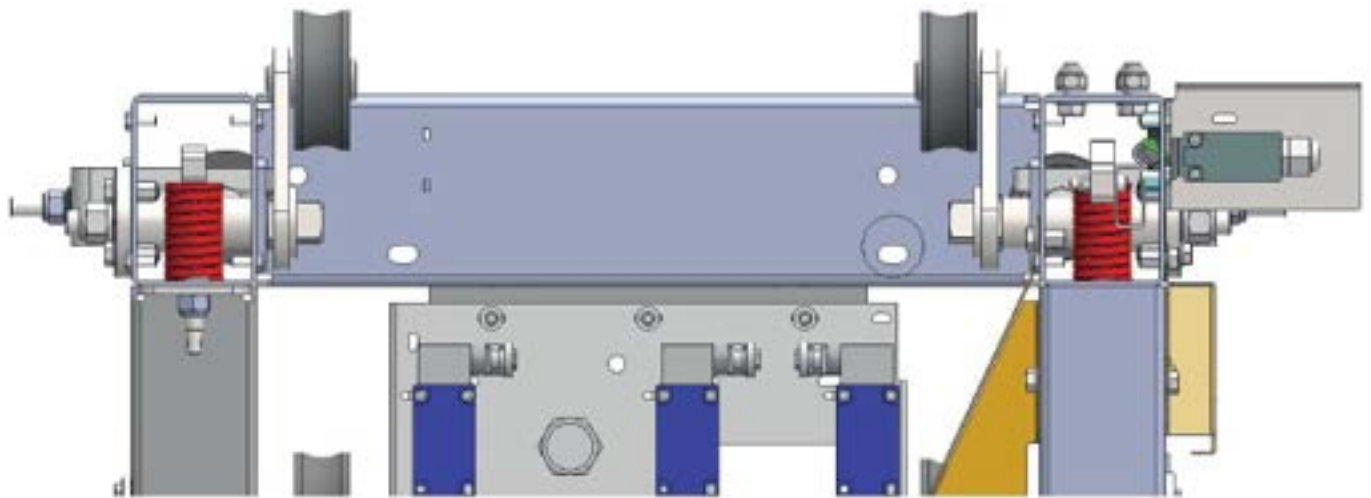

Figure 6.16

## 6.14 MOUNTING THE DOORS

### ATTENTION:

When positioning the landing doors on the floors consider that the ramps on the machine must come to engage the device for release of the door. Place the machine 24 inches away from landing doors.

#### 6.14.1 Mounting the hinged doors (TRANSPORT PLATFORM ONLY)

Proceed as follows:

- the door is supplied fully assembled and equipped with electrical and mechanical interlock system for installation safety and either safe passage of materials or persons
- people involved in the installation must exclusively position and fix the gate to the existing structure

### ATTENTION:

The door can be fastened with anchor bolts to the ground of the landing floor or connected to the traditional scaffolding or cantilever structure by means of supporting rods supplied.

- to fix it to the ground, place the door (1) and fasten it to the ground by means of anchor bolts, inserting the screws into the base support holes (2)
- to connect to traditional scaffolding or cantilever, mount the support rods (3) into the door fixed structure (4), place the door and fasten the supporting rods (3) by means of perpendicular clamps
- execute the electrical connections of all landing equipment

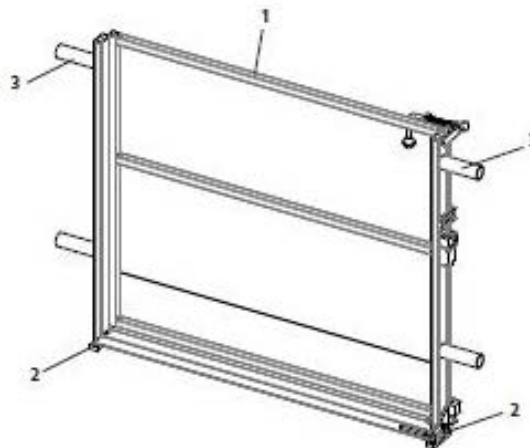

Figure 6.17



**This page has been left blank for formatting purposes**

# CHAPTER 7: COMMAND AND CONTROL DEVICES

Record of modifications

Revision	Executor	Date	Description of modification

## 7 COMMAND AND CONTROL DEVICES

### 7.1 GENERAL INFORMATION ON COMMAND DEVICES

The command devices installed on the control panels allow the operators to perform their duty by commanding the machine's entire cycle of operations in optimal conditions.

The machines can be commanded in different ways depending on whether they are to be used solely for transporting material or material and persons.

The MC1600TP/M (Transport Platform/Material Hoist) machines, intended to transport material and intended to transport material and persons have control panels on the base unit and onboard the machine, floor level calling control panels, and the control panel to test the safety brake device.

#### **ATTENTION:**

Some machines do not have the assembly control panel (the upward and downward commands and those for stopping at the floor levels are replicated on the onboard control panel) or the drop test keyboard.

#### **ATTENTION:**

By pressing one of the two drive buttons the loading unit will move in the desired direction and when it is close to the selected floor level you just press the STOP NEXT LANDING push button in TP mode, and the loading unit will stop when it reaches it. In MAT mode, the unit will always stop at a floor level, and the FLOOR BYPASS push button will need to be pushed to bypass the floor. The floor stop cam may need to be adjusted if the unit does not stop evenly at the floor level.

#### **ATTENTION:**

At both the top and bottom extreme ends of the path, the machine will stop automatically even if the drive button is kept depressed, since appropriate braking cams are installed on the mast.

The commands pertaining to the machine referred to in this manual are described in detail in the following paragraphs, therefore, it is of utmost importance to read this chapter attentively to use all the commands described correctly.

## 7.2 COMMANDS ON THE BASE CONTROL PANEL

Referencing figure 7.1, the electrical base control panel includes:

- 1 - Main switch/disconnect
- 2 - Signal light PRESENCE PHASE 1
- 3 - Signal light PRESENCE PHASE 2
- 4 - Signal light PRESENCE PHASE 3
- 5 - Up pushbutton
- 6 - Down pushbutton
- 7 - Stop Next Landing pushbutton
- 8 - Machine mode key selector (MATERIAL/TRANSPORT PLATFORM)
- 9 - Emergency pushbutton
- 10 - Plug for Trailing Cable
- 11 - Plug for Ground Enclosure Gate
- 12 - Plug for floor call boxes
- 13 - 3-Meter Lasts pushbutton

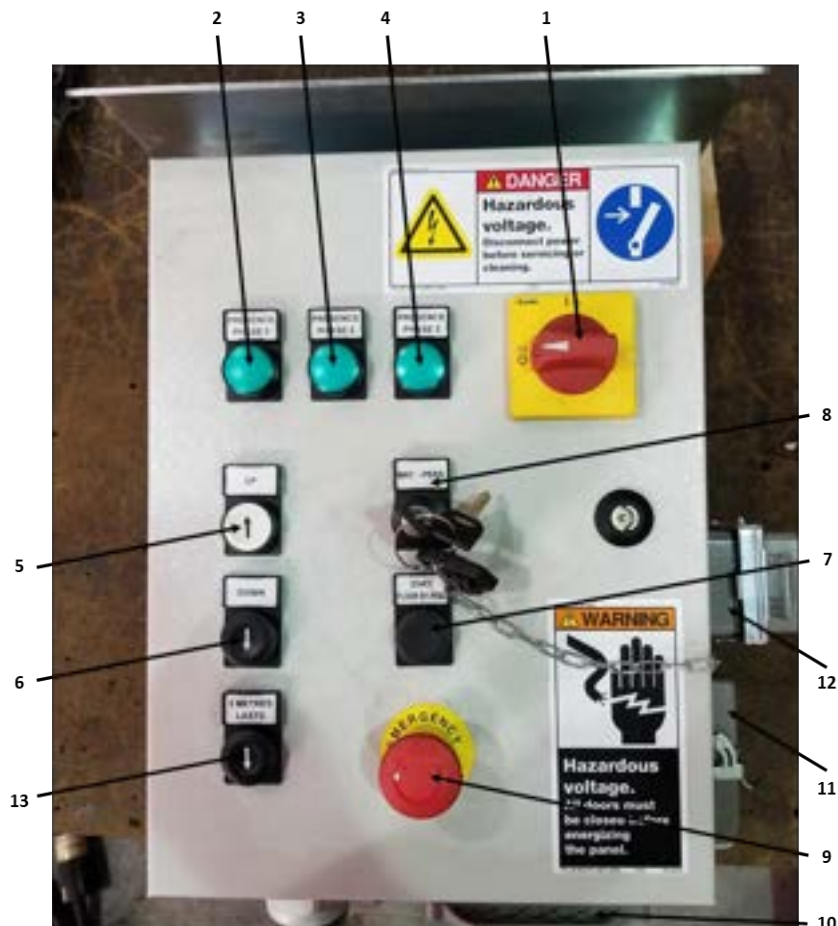

Figure 7.1

#### 7.2.1 Main switch/disconnect

The main switch/disconnect with the safety lock, locks in the zero position. This switch allows the operator to interrupt the power supply to the machine. With the safety lock mechanism, the switch prevents the control panel from being opened during normal operation, therefore, not allowing operations to be carried out to the internal part of the control panel with energized wiring. The switch also makes it possible to safely shut down the machine for all maintenance operations to be carried out by setting the safety lock in the zero position.

#### 7.2.2 Signal light PRESENCE PHASE 1

The green signal light informs the operator that the power supply on phase 1 is present.

#### 7.2.3 Signal light PRESENCE PHASE 2

The green signal light informs the operator that the power supply on phase 2 is present.

#### 7.2.4 Signal light PRESENCE PHASE 3

The green signal light informs the operator that the power supply on phase 3 is present.

#### 7.2.5 UP pushbutton

The UP pushbutton allows the operator to control the machine towards the upper floors when the Machine Mode is in Material mode.

#### 7.2.6 DOWN pushbutton

The DOWN pushbutton allows the operator to control the machine towards the lower floors when the Machine Mode is in Material mode.

#### 7.2.7 START/FLOOR BYPASS pushbutton

The START/FLOOR BYPASS pushbutton engages the unit to allow UP and DOWN travel functions only in "MATERIAL" mode. It also allows the operator to bypass a floor level, towards which the machine is traveling. This function applies to both the upward and downward movements of the machine.

#### 7.2.8 Machine mode key selector (MATERIAL/TRANSPORT PLATFORM)

The two-way key selector (MATERIAL/TRANSPORT PLATFORM) allows the installer to select one of the two working conditions according to the operations that are to be conducted on the machine. If the selector is in "MAT" position, the machine is set to allow the operations of the FLOOR CALL BOXES and GROUND CONTROLS to operate in Material mode. If the selector is rotated in the "TP" position the FLOOR CALL BOXES and GROUND CONTROL functions are disabled.

#### 7.2.9 EMERGENCY pushbutton

This is a safety device and once pressed, the supply voltage of the main contactor is interrupted. The operator can intentionally rotate the same button in the directions indicated on the face to restore the system. This operation prevents the restore system from being made by mistake which could put the operator at risk.

#### 7.2.10 Plug for Trailing Cable

The connector connects the ground box to the cabin box.

#### 7.2.11 Plug for Ground Enclosure Gate

The connector connecting the ground enclosure gate switch (if supplied).

#### 7.2.12 Plug for Floor Call Boxes

The connector allows the operator to control the machine from floor levels in MATERIAL mode. The STOP button is always functional in both modes. In “MAT” mode the ENGAGE/FLOOR BYPASS button must be pressed once before the UP or DOWN buttons operate the travel of the unit. The unit will stop at all floor locations in the FLOOR STOP CAMS are installed. The ENGAGE/FLOOR BYPASS button will need to be pressed to bypass the floor levels.

#### 7.2.13 3-METER LASTS pushbutton

The 3-METER LASTS pushbutton allows the operator to command the loading unit downward to the ground level after stopping at 10ft from the ground by the intervention of a specific safety switch in “TP” mode.

### 7.3 COMMANDS ON THE ONBOARD CONTROL PANEL

Referencing figure 7.2, the onboard control panel includes:

- 1 - Main switch.
- 2 - Signal light NORMAL LOAD
- 3 - Display touchscreen
- 4 - Automatic greaser selector
- 5 - Machine mode key selector (MATERIAL/TRANSPORT PLATFORM)
- 6 - OVERTRAVEL BYPASS key selector with spring return
- 7 - Numeric keypad
- 8 - START pushbutton
- 9 - Electric panel lock
- 10 - 3-Meter Lasts pushbutton
- 11 - EMERGENCY pushbutton
- 12 - Signal light FULL LOAD
- 13 - Signal light OVERLOAD
- 14 - Acoustic advisor
- 15 - Plug for TRAILING CABLE
- 16 - Plug for Drop test pendant

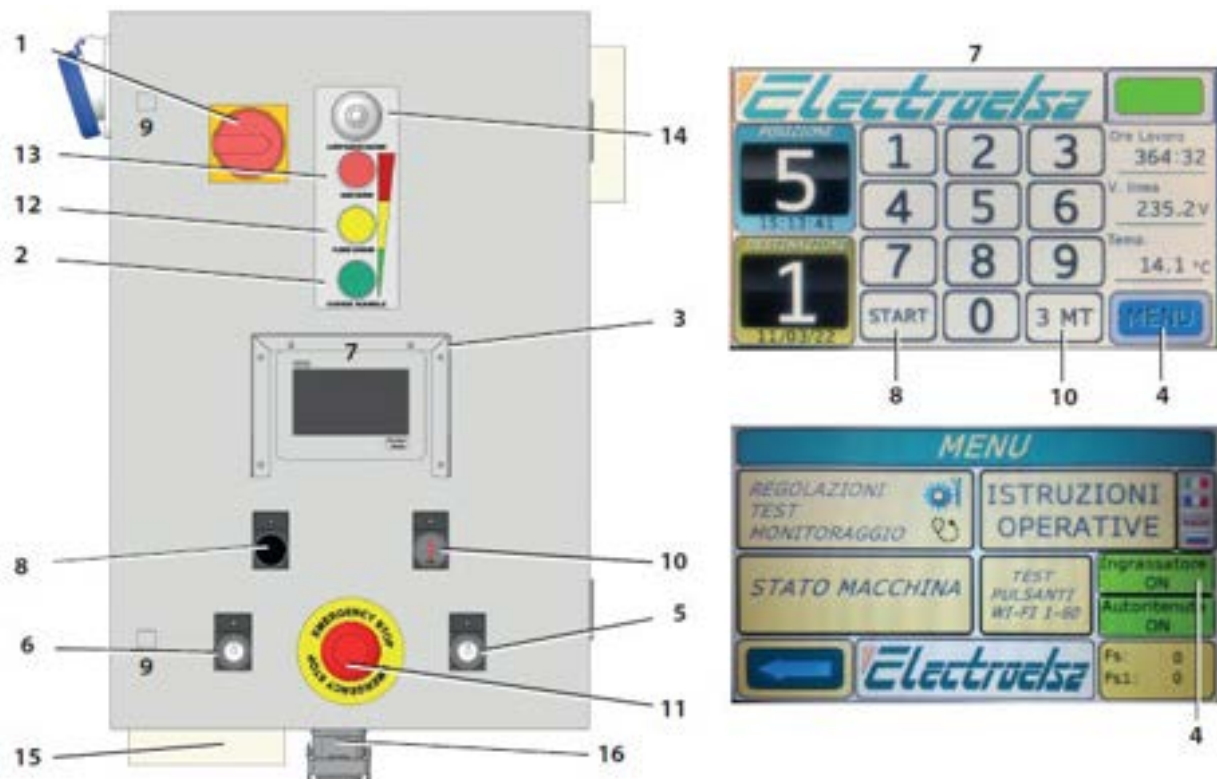

Figure 7.2

### 7.3.1 Main switch

The main switch locks in the “OFF” position. It is placed on the electrical power control panel and allows you to interrupt the power supply to the machine. It makes it possible to safely shutdown the machine for all maintenance operations to be carried out, by setting the safety lock in the “OFF” position.

### 7.3.2 Signal light NORMAL LOAD

The light is green and signals that the charge on the machine is lower than the maximum payload admitted. The green light stays always on.

### 7.3.3 Display Touchscreen

The touchscreen display shows all the information on the operation of the machine and commands given. It is used to give commands to the machine, detect data, and monitor the movements. If necessary, it shows alarms and malfunctions warnings.

### 7.3.4 Automatic Greaser

The selector for the automatic grease is located in the menu section of the touchscreen. This toggle enables or disables the automatic greaser during the upward movement of the machine.

### 7.3.5 Machine mode key selector (MATERIAL/TRANSPORT PLATFORM)

The two-way key selector (MATERIAL/TRANSPORT PLATFORM) allows the installer to select one of the two working conditions per the operations that are to be carried out on the machine. If the selector is rotated in the “MAT” position, the machine is set to allow operation of the ground controls. If the selector is in the “TP” position, only the cabin controls will operate the unit.

### 7.3.6 OVERTRAVEL BYPASS key selector

This key selector with spring return allows you to return the machine from the overtravel position. You may be required to implement this process if the machine (for example after descending the machine manually) has reached a position which has caused the overtravel limit switch to intervene.

### 7.3.7 Numeric keypad

The numeric keypad is used to input the desired floor to reach.

#### 7.3.8 START pushbutton

The START pushbutton allows the operator to command the machine towards the floors selected via the keypad, both up and down. To reach the desired floor, key in the floor number and press and hold the START pushbutton. During decent, when you arrive at the 3Mt stop, press and hold the 3Mt Lasts pushbutton in conjunction with the START pushbutton.

#### 7.3.9 Electric panel lock

Panel locking mechanism.

#### 7.3.10 3-M push button

The 3-M push button allows the operator to command the loading unit's downward to the ground level after stopping at 10 ft from the ground by the intervention of a specific safety switch in "TP" mode.

#### 7.3.11 EMERGENCY pushbutton

There is a safety device that once pressed the supply voltage of the main contactor of the electrical control panel is interrupted. The operator can intentionally rotate the same button in the direction of the arrow on the button face to enable the electrical power to be restored.

#### 7.3.12 Signal light FULL LOAD

The light is yellow and signals that the charge on the machine has reached 70% of the allowable load. The yellow light is switched off if the charge on the machine is under 70% of the rated load.

#### 7.3.13 Signal light OVERLOAD

The light is red and signals that the charge on the machine has exceeded the maximum rated load. When the red light is switched on, an acoustic advisor emits an audible tone and power to the motors is removed. The red light switches off when the charge on the machine returns to allowable parameters.

#### 7.3.14 ACOUSTIC ADVISOR

The acoustic advisor intervenes when the charge on the machine has exceeded the maximum allowable payload. The warning alarm intervenes at the same time as the overload red light.

#### 7.3.15 Plug for TRAILING CABLE

The connector, installed in the lower part of the control panel, allows the power supply and the command to the connection cable with the base panel.

## 7.4 COMMANDS ON GROUND CONTROL PENDANT (if equipped)

Referencing figure 7.3 the keyboard includes:

1. **UP push button**
2. **DOWN push button**
3. **ENGAGE/FLOOR BYPASS push button**
4. **EMERGENCY push button**

### 7.4.1 UP push button

The UP push button allows the operator to control the machine towards the upper floor levels only in “MATERIAL” mode.

### 7.4.2 DOWN push button

The DOWN push button allows the operator to control the machine towards the lower floor levels only in “MATERIAL” mode.

### 7.4.3 ENGAGE/FLOOR BYPASS push button

The ENGAGE/FLOOR BYPASS push button engages the unit to allow UP and DOWN travel functions only in “MATERIAL” mode. It also allows the operator to bypass a floor level, towards which the machine is going. This function is applicable for both upward and downward movements of the machine.

### 7.4.4 EMERGENCY push button

This is a safety device and once it is pressed, the supply voltage of the main contactor of the electrical control panel is interrupted. The operator can intentionally rotate the same button in the same direction of the arrows to enable the restore system. This operation prevents the restore system from being enabled by mistake which would put the operator at risk.

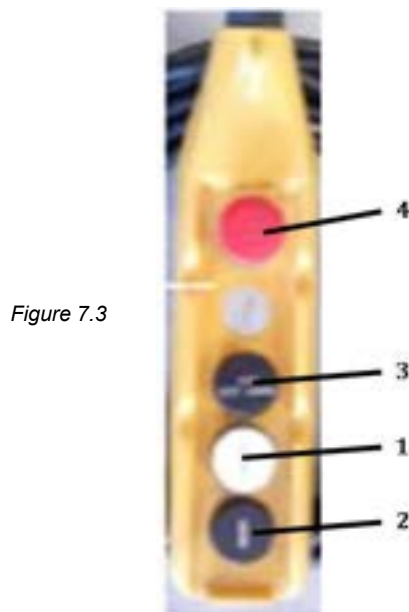

## 7.5 COMMANDS ON FLOOR CALL BOXES

Referencing figure 7.4 the keyboard includes:

1. **UP** push button
2. **DOWN** push button
3. **ENGAGE/FLOOR BYPASS** push button
4. **EMERGENCY** push button
5. **Plug for floor call box**

### 7.5.1 UP push button

The UP push button allows the operator to control the machine towards the upper floor levels only in “MATERIAL” mode.

### 7.5.2 DOWN push button

The DOWN push button allows the operator to control the machine towards the lower floor levels only in “MATERIAL” mode.

### 7.5.3 ENGAGE/FLOOR BYPASS push button

The ENGAGE/FLOOR BYPASS push button engages the unit to allow UP and DOWN travel functions only in “MATERIAL” mode. It also allows the operator to bypass a floor level, towards which the machine is going. This function is applicable for both upward and downward movements of the machine.

### 7.5.4 EMERGENCY push button

This is a safety device and once it is pressed, the supply voltage of the main contactor of the electrical control panel is interrupted. The operator can intentionally rotate the same button in the same direction of the arrows to enable the restore system. This operation prevents the restore system from being enabled by mistake which would put the operator at risk.

### 7.5.5 Plug for floor call box

The connector allows you to connect the floor call box with the machine's control system.

Figure 7.4



## 7.6 COMMANDS ON THE DROP TEST PENDANT

Referencing figure 7.5 the keyboard includes:

1. **UP push button**
2. **TEST push button**
3. **EMERGENCY push button**

### 7.6.1 UP push button

The UP-push button allows the operator to control the machine towards the upper floor levels only in “PERSONS” mode.

### 7.6.2 TEST push button

The TEST push button allows a qualified operator to carry out the test on the safety brake device only in “TP” mode. The test allows you to ensure that the safety brake system functions perfectly. After every test, the intervention system must be restored by following the instructions given in the relevant paragraph.

### **WARNING:**

**This button opens the motor brakes, causing the free fall of the machine therefore must be pressed only by a qualified operator.**

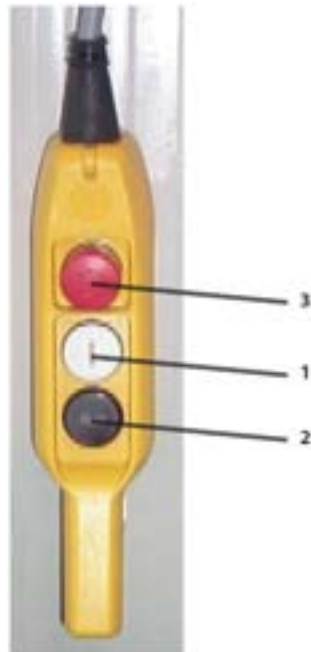

Figure 7.5

### 7.6.3 EMERGENCY pushbutton

This is a safety device and once it is pressed, the supply voltage of the main contactor of the electrical control panel is interrupted. The operator can intentionally rotate the same button in the same direction of the arrows to enable the restore system. This operation prevents the restore system from being enabled by mistake which would put the operator at risk.

#### **DANGER:**

**The operator is authorized to exclusively carry out the restore operations as described in the relevant paragraph. NO INTERVENTION MUST BE IMPLEMENTED ON THE SAFETY BRAKE DEVICE. Such interventions are the exclusive responsibility of BETA MAX Technical Support.**

## 7.7 OVERLOAD DETECTION DEVICE

The lifting unit is equipped with a load control device. This device (essentially composed of a system of springs and position sensors together with a series of signal lights and an acoustic device) has the task of checking that the lifting unit is never loaded with weights greater than those that can be safely tolerated or braked.

The device has two alarm thresholds calibrated and verifiable directly on the lifting unit:

- Limit load at approximately 70% of the rated load, when reached, activates a yellow signal light indicating proximity to the load limit.
- Overload at approximately 100% of the rated load, when reached, activates a red signal light and audible alarm and inhibits the movement of the machine.

The red signal light and audible alarm switch off when the load on the machine returns to within the load parameters allowed by the device.

To test the correct functioning of the device, simply use a small screwdriver on sensors 1 (yellow light) and 2 (red light) as in the figure below.



## CHAPTER 8: SAFETY REGULATIONS

Record of modifications

Revision	Executor	Date	Description of modification

## 8 SAFETY REGULATIONS

### 8.1 DESCRIPTION OF THE MACHINE'S SAFETY SYSTEMS

The machine is equipped with effective safety systems. The loading unit (1), intended for transporting materials and/or persons, is a completely closed structure equipped with access ramps (2) which interlock both mechanically and electrically. The area surrounding the machine is completely protected with the base enclosure (3) or barrier system.

#### **DANGER:**

It is absolutely forbidden to operate the machine without the above-mentioned protection devices in place. It is absolutely forbidden to replace the protection devices with others, which do not meet the requirements of safety legislation. Such implementations could cause considerable injuries and damage the mechanical components.

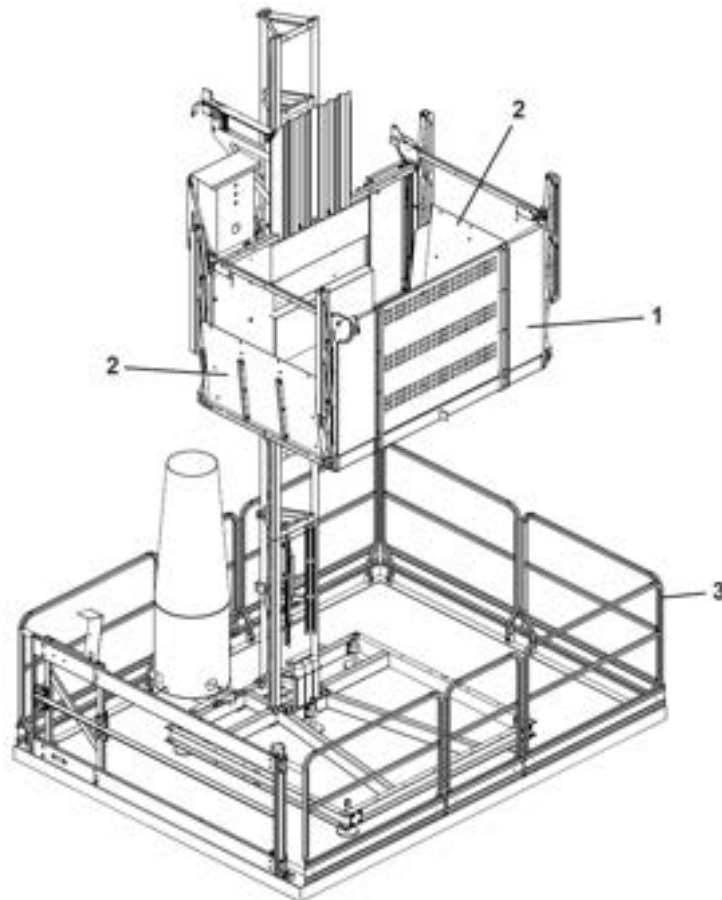

Figure 8.1

## 8.2 MOVABLE GUARDS

Sheet metal panels or doors made of steel bars and steel mesh are set in place to close off parts of the machine used to transport materials and/or persons, or areas which can be particularly dangerous due to the machine's movable parts or to an area where electricity passes. The machine is equipped with movable guards for the access door of the base enclosure and for that of the loading unit; these are controlled electrically and interlock mechanically as well as movable guards for the electrical control panels, which lock with a key.

### 8.2.1 Electrically controlled and mechanical interlocking movable guards

The electrically controlled movable guards that interlock mechanically are applied to the base enclosure access door, the ground floor access ramp to the loading unit and the doors leading to the floor level landing platforms. The control system consists of position detection switches and a mechanical interlocking system. If the door is open or not closed properly, the switch is not pressed; therefore, the machine cannot be operated. If the loading unit and the floor level doors are not aligned correctly, the mechanical interlocks prevent the doors from being opened.

The movable guards are shown in figure 8.2; the ramps (1) allows access to the loading unit supported by the hinged doors (2) and of the mast guard (3).

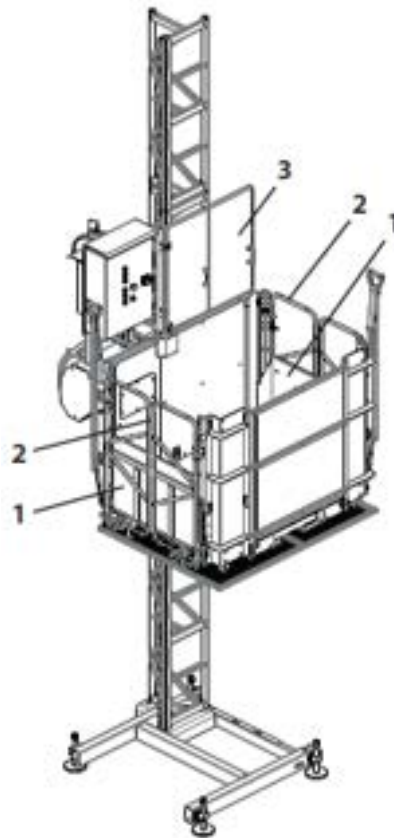

Figure 8.2

### 8.2.2 Electrically controlled movable guards

The electrically controlled movable guards consist of protection bars placed close to the loading unit access ramps and the platform used for mounting the wall anchors.

The guards are shown in figure 8.3; the bars (1) allow closing the upper part of ramps giving access into the loading unit; the movable bar (2) is the upper guard of platform used for assembling the wall anchors.

#### **ATTENTION:**

It is forbidden to work with the movable guards open, by-passing the switches control. If the machine is deprived of the safety electrical controls or the same controls are replaced with others which are not original and not adequate, BETA MAX denies all responsibility for damage caused to the machine and injuries caused to persons.

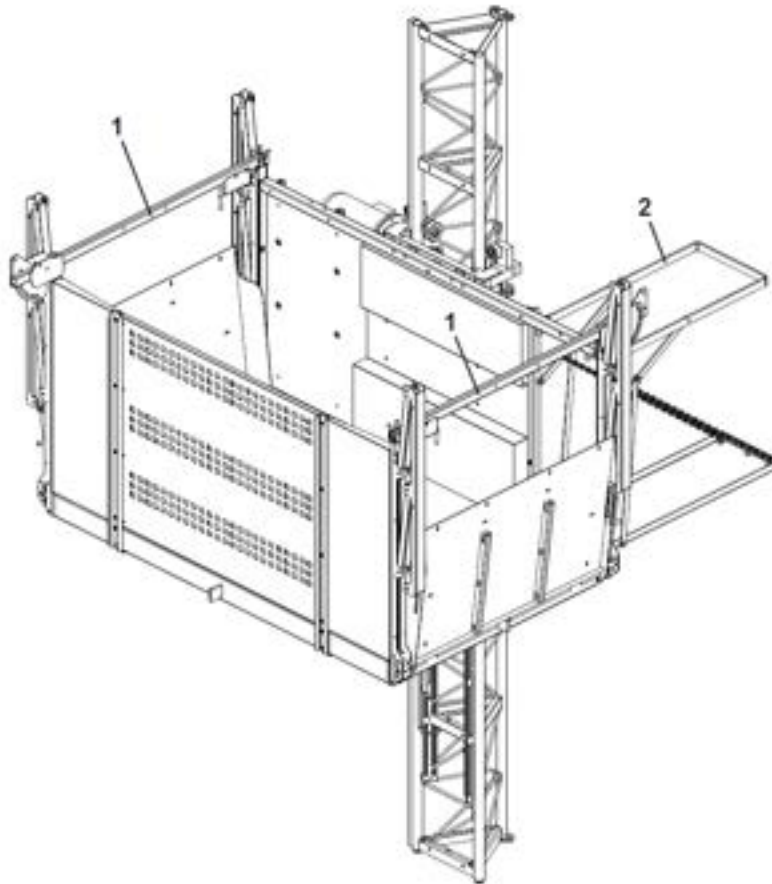

Figure 8.3

### 8.2.3 Movable guards which lock with a key or tool

The movable guards which lock with a key or tool are applied to the panels used to close the electrical base control panel and that found onboard the machine. The main switch on the onboard control panel and be locked in the “OFF” position.

**DANGER:**

Before accessing the internal parts of the electrical control panels, wait at least 15 minutes after the machine is switched off, so that some internal electrical components can dispel any dangerous residual energy they may have.

**DANGER:**

The locking keys must never be left in the control panels when the machine is in normal operation but must be safely kept by the technical maintenance personnel or by the specialized expert who has been designated to carry out any electrical operations.

### 8.3 FIXED GUARDS

Structures made of steel rods and bars and metal sheets are placed to protect some areas of the loading unit, where are not present the access ramps or where are particularly dangerous areas of the machine which allow access to areas reserved for personnel responsible for conducting installation and maintenance operations, and the areas where machine's members are in motion.

The main fixed guards are listed below:

1. enclosing panels of the loading unit
2. fastening bar for safety devices on the small assembly platform
3. cover onto the gear motor pinion (there can be more than one device)
4. cover onto the parachute pinion (it can be welded onto the support)
5. mast protection panel

#### **DANGER:**

The machine must NEVER be started up and used without the fixed guards being properly installed. All the fixed guards must ALWAYS be installed before the platform is elevated and the installation operations begin.

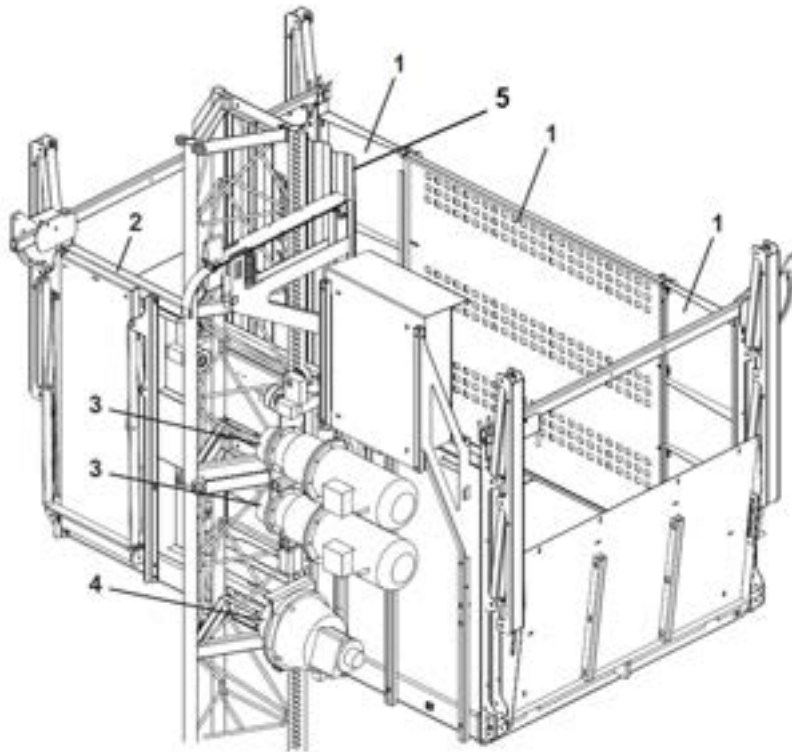

Figure 8.4

## 8.4 SAFETY EQUIPMENT

The machine is supplied with the following safety equipment:

- mechanical equipment
- electro-mechanical equipment
- electrical equipment
- overload control device (optional)

### 8.4.1 Mechanical equipment

The following mechanical safety devices are installed on the machine:

- safety hooks on the lifting unit
- silent block shock absorbers on the base unit
- mechanical and electrical interlock on the access doors

The safety hooks are welded on the lifting unit to prevent the unit from coming off the mast, should the operator inadvertently drive the machine beyond the end of the vertical mast whilst lifting the cabin upwards. These hooks keep the lifting unit hooked to the vertical mast. The silent blocks, also called shock absorbing buffers, are mounted on the base unit to cushion the metal contact between the loading unit and the base unit in the event of an incorrect maneuver implemented by the operator, or if the loading unit free-falls. With reference to modest impacts, these buffers will prevent damaging the loading unit and the base unit.

The electrical and mechanical interlocking devices found on the floor landing doors and on and the base enclosure doors, prevent the doors from being opened if the machine is not at a standstill and in the correct position for access; obviously, if the doors are open, the electrical devices prevent the machine from moving.

### 8.4.2 Electro-mechanical equipment

The following electromechanical safety devices are installed on the machine:

- safety brake device with progressive braking
- safety cam on the platform used for assembly operations

The safety brake is a safety device, which intervenes and stops steadily the loading unit, if it descends with an excessive speed. Moreover, the safety brake device is equipped with a switch that indicates the intervention by interrupting the main contactor. Therefore, it will not be possible to put the machine back on until the cause which provoked the intervention is identified and resolved. The safety cams on the platform used for assembly operations prevent the machine from moving unless these are properly closed.

### 8.4.3 Electrical equipment

On the machine are identifiable service switches and security switches. Service switches are the normal switch for the ascent and descent. The switches that concern the safety of the loading unit are:

- switch for upward overtravel
- switch for downward overtravel
- safety switch on the access doors of the loading unit
- safety switch on the cam of the platform used for assembly operations
- mast presence switch

Moreover, a normally closed contact EMERGENCY push button is found on the machine.

#### **SWITCH FOR UPWARD OVERTRAVEL**

The upward overtravel device consists of a switch with a small wheel and the overtravel pad, which is installed about 2 inches above the upward end-of-travel pad. The switch intervenes by interrupting the 110 V control circuit, which in turn intervenes on the main contactor. This device can be reset in the following way:

- acting upon the manual brake release, which is placed on the motor and moving slightly downwards.

#### **SWITCH FOR DOWNWARD OVERTRAVEL**

The downward overtravel device consists of a switch which is physically coupled and mounted to the downward switch, on the lifting unit. The downward overtravel pad is placed in a lower position from the downward end-of-travel pad. This device intervenes:

- in the event of the downward switch breaking or malfunctioning
- if the loading unit, even slightly, after the downward braking pad stops it. Therefore, the device is also an indicator of the wear and tear of the gear motor brakes and of excessive load on the machine
- in the event of failure in voltage when descending, in an emergency; by means of the manual brake releases, the machine is stopped on the shock absorbers of the base unit

The downward overtravel switch intervenes by interrupting the 110 V control circuit, which in turn intervenes on the main contactor.

The reset of the device can be done by turning the key switch OVERTRAVEL BYPASS on the control panel to position “1” while in “TP” mode.

### ***SAFETY SWITCH ON THE ACCESS DOORS OF THE LOADING UNIT***

The safety switch on each access door is positioned on the vertical support of the loading unit where the bar turns. If the ramp is opened or not properly closed, during the machine's normal operation, the switch prevents the movement of the machine.

Just like all the other devices described above, the switch intervenes by interrupting the entire 110 V control circuit, which in turn intervenes on the main contactor. The device can be reset by the closing of the access door correctly whilst ensuring that the head of the switch is not broken, flattened, or altered in any way.

### ***SAFETY SWITCH ON THE CAM OF THE PLATFORM USED FOR ASSEMBLY OPERATIONS***

The safety switch on the small platform used for assembly operations prevents the machine from moving if this platform is not properly closed. Just like all the other devices described above, the switch intervenes by interrupting the entire 110 V control circuit, which in turn intervenes on the main contactor. The device can be reset by the correct closing of the access door whilst ensuring that the head of the switch is not broken, flattened, or altered in any way and that it is placed perfectly in the center of the cam shaft.

### ***MAST PRESENCE SWITCH***

The mast presence switch is installed on the upper part of the lifting unit, preventing the movement of the machine when the group itself does not stop on the upward overtravel switch or during assembly if the machine was made up incorrectly above the last mast installed. The switch intervenes by interrupting the 110 V control circuit, which in turn intervenes on the main contactor. This device can be reset in the following way:

- acting upon the manual brake release, which is placed on the motor and moving slightly downwards.

### ***EMERGENCY PUSHBUTTON***

On the control panels supplied with the machine, there are clearly visible red mushroom push buttons used to stop the machine in case of emergency (stop-emergency). Should the need arise, pressing one of these pushbuttons will interrupt the entire 110 V control circuit, which in turn intervenes on the main contactor: acting in the same way as a normal safety switch. Once pressed, this remains pressed. To restore the machine back to normal operation, at the end of the emergency, the push button must be rotated, reconnecting its normally closed contact, which is opened by the pressure exerted when the operator presses on it.

#### **8.4.4 Overload control device (if equipped)**

A load cell, an overload signaling device equipped with different colored signal lights and an acoustic advisor allow the operator to check the load charged of the machine at any time.

The green light switched on means that the machine can work properly.

The orange light means that the charge on the machine has exceeded 70% of the maximum payload admitted.

In case of red light switched on and intervention of the acoustic advisor the charge on the machine has exceeded the maximum payload admitted and as consequence the power supply cut off.

## 8.5 LIST OF PLATES FOUND ON THE MACHINE

The machine is equipped with a series of adhesive plates, which correspond to dangerous areas, to immediately signal dangers which the operator can face. This paragraph is intended to point out where the signs are found on the machine and explain their meaning. The signs found on the machine are:



**1 - General danger.** Consult the instruction manual in case of maintenance, adjustment, particular use, etc.



**2 - Danger: moving parts.** This sign indicates that there are chains, mechanisms and other working components within the guarded areas.



**3 - Individual protection gear is necessary.** These signs indicate the type of individual protection gear to use (gloves, noise protection earmuffs and safety shoes).



**4 - Pinching/shearing hazard.** There is a risk of having your hands pinched/sheared, if placed close to the equipment during work in progress.



**5 - Obligatory use of indicated point.** The sign indicates which points are to be used for lifting (to insert the lifter blades or the hook used for the fastening system).



**6 - Risk of electric shock.** In proximity to this signal, you are in presence of electric voltage and there is the danger of electric shock.

Every time the machine is installed, the site manager who is responsible for the installation must see to apply the capacity plate pertaining to the layout of the machine. The plate indicates the measurements of the installed machine's configuration and the maximum rated loads allowed, in relation to such a configuration. The plate must be placed inside the loading unit in such a way to be immediately visible by the operator.

### 8.5.1 Signs onboard the machine

Self-adhesive signs are placed on the machine in order to indicate dangerous points, such as where the rack and pinion fit together on the lifting unit, where there are the access ramps gears that allow its closing and in points where one needs to be aware of live parts in order to avoid contact, such as inside the electrical control panel. The figure shows the layout of such signs:

1. **Danger moving parts.** This sign (1) indicates the presence of moving parts such as chains and mechanisms for motor transmission
2. **Pinching/shearing hazard.** This sign (2) indicates that there is a risk of having your hands pinched/sheared if placed near the closures of the loading unit's access ramps
3. **Danger live parts.** This sign indicates that one must be aware of live parts when opening the hatch of the electrical control panel, even after having rotated the main contactor to the "OFF" position. The sign is found on the electric base control panel and on the onboard control panel.

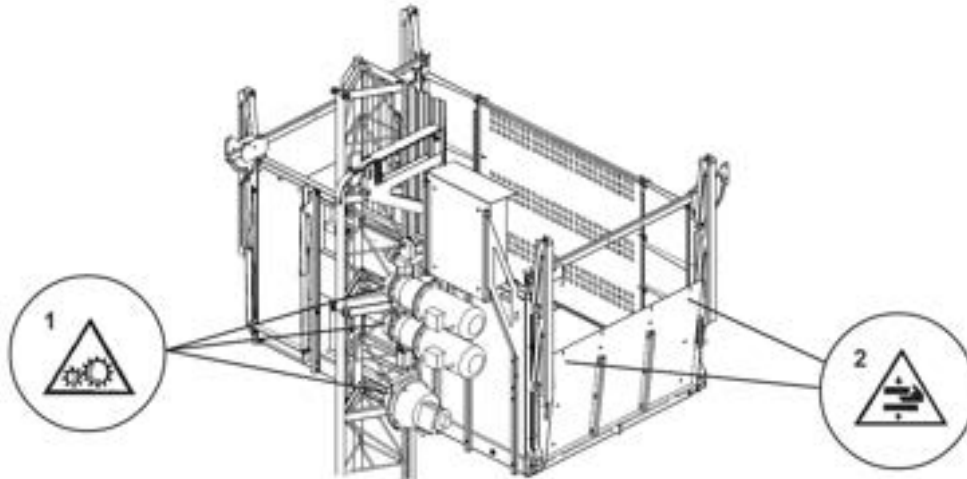

Figure 8.5

Other signs are placed inside the loading unit to identify the type of machine, the load and safety indications to be adhered to during operation and installation.

The figure shows the layout of such signs:

1. **Identification plate.** The sign provides a clear identification of the type of machine, the manufacturer, the serial number, and the machine's main characteristics.
2. **Load plate.** The sign allows you to clearly see the possible load combinations which the machine is designed for.
3. **Safety indications plate.** The sign describes the safety requirements that are necessary to operate the machine, including those of qualified operators.
4. **Safety indications plate.** This sign allows you to clearly see the safety requirements to be adhered to, to avoid dangerous situations during the installation of the vertical components.

## 8.6 FUNDAMENTAL SAFETY REGULATIONS

Over the years, serious accidents have occurred during the assembly and disassembly operations of machines having a rack and pinion. These accidents have human factors in common, such as failing to comply with safety regulations and lack of good sense. This document is for all personnel, including general workers, involved in the assembly and disassembly operations and those assisting in such operations.

As an example, if a worker leans out of the opening that is used to mount the masts, while the machine is in motion, he can be hit by a wall anchor; or, if the bolts used on the vertical mast are not completely installed and tightened, this may cause the mast sections to separate and the lifting unit to fall, resulting in serious injuries or possible fatalities. Many other cases or examples can be given. To avoid accidents from being caused, read these instructions attentively. Do not be hasty in carrying out your work and always ensure that it has been done properly.

### 8.6.1 General safety regulations

Always adhere to the indications described below to carry out correct installation, use and maintenance operations:

- read all the warnings and instructions related to the work and/or danger
- keep the work area clean. Any oil spills must be immediately removed, to avoid the risk of slipping; to reduce the risk of stumbling over unnecessary material, remove them immediately (disassembled parts of the machine or any other)
- under no circumstances is the machine to be put in motion if a person is inside the base enclosure when the loading unit is raised onto the mast or at an anchor level. The power supply must be interrupted during these operations
- complete each operation before starting another or before taking a break. This is particularly important when the sections of the vertical mast are being tightened and when the anchors or other structural parts are being installed
- always apply the required torsion when tightening junction bolts (it is recommended to use a dynamometric wrench), as shown in the relative specifications table
- if structural damage or significant corrosion is noticed in parts such as the mast sections or the anchors, machine operation must be immediately stopped, and the damage must be identified and repaired before operating the machine again (these operations are to be carried out exclusively by authorized and particularly experienced personnel, otherwise, you must contact Beta Max Technical Support)

### 8.6.2 Local safety regulations

Strictly adhere to all national safety regulations in the country where the machine is installed.

### 8.6.3 Environmental conditions

The machines must not be assembled or disassembled if the wind speed exceeds 28 mph. In countries where local regulations are more restrictive, abide by the specific indications.

#### 8.6.4 Pre-installation requirements

To install the machine correctly, the designated technical expert must:

- study the use and maintenance instruction manual attentively before starting the work
- secure the assembly/disassembly area from objects that may fall, by delimiting or closing off the area in such a way to prevent access to outsiders, who are not authorized or who are not equipped with suitable protection devices or gear
- forbid unauthorized personnel from accessing the machine, during assembly, disassembly and normal operation

#### 8.6.5 Individual protection gear regulations

Protection and safety gear pertaining to the work being carried out must be used and/or worn, such as hard hats, safety shoes, safety harness, or any other which is suitable to prevent injuries.

### **DANGER:**

It is absolutely prohibited to work on the machine without utilizing the above-mentioned personal protection equipment.

#### 8.6.6 Regulations pertaining to electricity

Only competent personnel are to perform work on electrical parts. The power supply must be interrupted and shut off before commencing such work. All necessary measures must be taken to prevent the power supply from being turned back on, even inadvertently.

#### 8.6.7 Regulations pertaining to spare parts

Only original or approved spare parts must be used.

## 8.7 REGULATIONS PERTAINING TO MAXIMUM LOADS

The admissible load on the machine must be in accordance with its configuration and the tables placed on the machine itself regarding maximum loads.

The site manager, who is responsible for the installation process, must verify the machine's layout and affix the plate indicating the loads, relative to this layout, as stipulated earlier on.

### **NOTE:**





All data pertaining to the maximum installation height, loads and maximum number of persons allowed to be transported on the machine, strictly pertains to standard installations given in this manual and is not applicable to non-standard configurations.

### **ATTENTION:**

You are recommended to contact BETA MAX technical support regarding non-standard installations, which are not included in this manual.

Hereunder are the machine’s load characteristics pertaining to persons and material that may be transported.

MC1600TP/M V installed as a Transport Platform may have a maximum of 4 people (including the operator) and an additional weight of 800 lbs. (**ANSI/SAIA A92.10**)

<b>CAPACITY</b> (LBS)	
	<b>1600</b>
	<b>+1400</b>
	<b>+1200</b>
	<b>+1000</b>
	<b>+800</b>

10-009

Figure 8.6

MC1600TP/M V installed as a Material Hoist may have a maximum of 1600 lbs. and **“NO RIDERS ARE ALLOWED” (ANSI/ASSE A10.5)**

**ATTENTION:**

MC1600TP/M in material hoist mode is not allowed to have riders during operation except for erection, dismantle, and servicing by authorized and trained personnel.

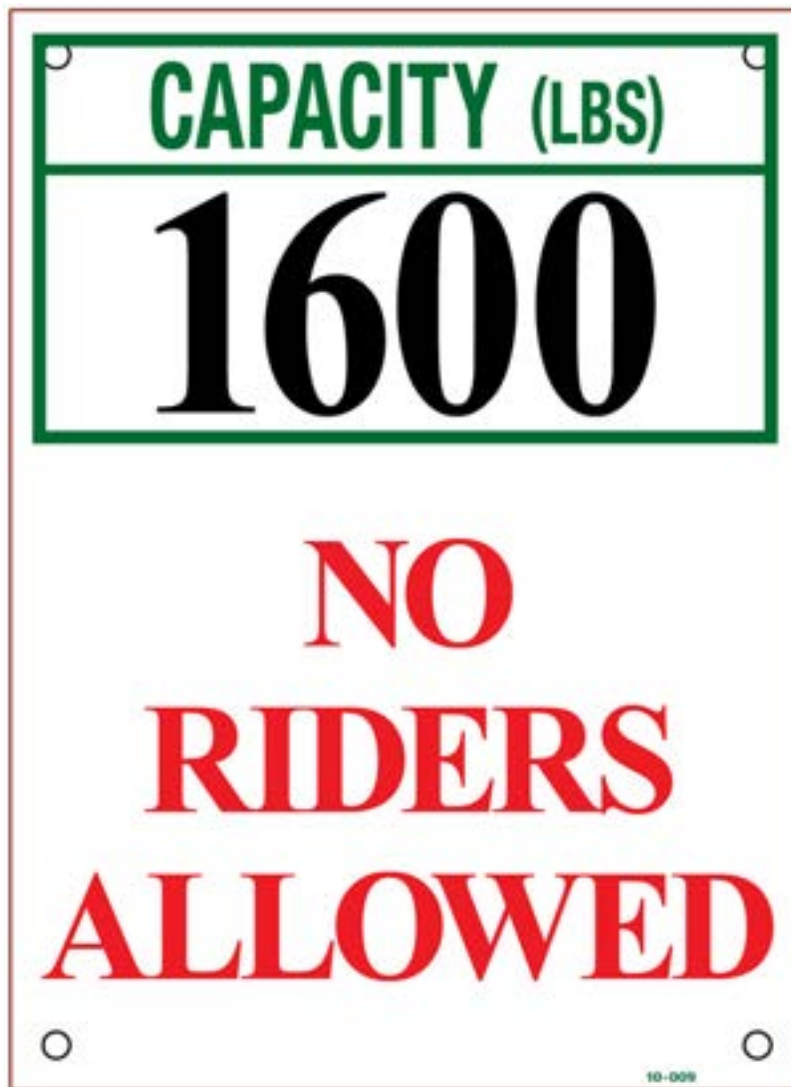

Figure 8.7

## 8.8 RESIDUAL RISKS

This paragraph is intended to highlight the residual risks associated with the operations covered in this manual. The major risks can be identified in the situations mentioned below:

- risks arising from operating with configurations not provided for by the manufacturer
- risks arising from positioning the machine incorrectly
- risks arising from transporting the machine
- risks arising from incorrect assembly on the ground
- risks arising from incorrect overground assembly
- risks arising from functional verification of the machine
- risks arising from the machine's normal operation
- risks arising from descending the machine manually
- risks arising from handling the machine in the construction site
- risks arising from disassembling the machine

A detailed description is given for each of these situations, indicating the stage of operations, the equipment used, the possible risks and relative prevention and safety measures.

### 8.8.1 Risks arising from operating with configurations not provided for by the manufacturer

The measurements of the machine and its conformation in respect to the building in question must be confirmed in the construction site itself, before commencing the machine's assembly operations. The drafted and executive project plans of the building in question together with the Use and Maintenance Instruction Manual of the machine must be consulted for such verification.

Possible risks:

- differences between the measurements in the plans and the actual measurements of the building
- overground obstacles
- verification of the machine's anchor positions
- errors in the assembly configuration of the machine

Prevention and safety measures:

- verification of any overground obstacles in the construction site that prevent the regular assembly of the machine, regarding power and telephone lines anchored to the building. In the case of obstacles being found, a different configuration must be planned for the machine
- the person responsible for the installation process must decide upon the positions of the wall anchors in accordance with the Instruction Manual. If the standard solutions given in the Instruction Manual cannot be implemented because of particularities in the construction site, a plan must be drawn up for every anchorage and signed for by a qualified professional
- the person responsible for the installation process must ensure that the configuration chosen, based on the above-mentioned considerations, is mounted with no variations or modifications

### 8.8.2 Risks arising from an incorrect positioning of the machine

The position where the machine will be mounted is defined and the machine is prepared for this operation.

For this operation, the drafted and executive project plans of the building in question must be consulted regarding the underground and underlying conformation of the area chosen, together with the Use and Maintenance Instruction Manual of the machine.

Possible risks:

- weak flooring is chosen for the installed base unit to rest on
- underground pipelines or cavities
- difficulties with the power supply

Prevention and safety measures:

- the total load that will weigh on the machine's base unit flooring must be determined beforehand, based upon the indications given in the Instruction Manual. The person responsible for the installation must communicate the total intended loads to the Qualified Technician, who is designated by the Firm or by the Owner. After having carried out the necessary verification calculations, the Technician will issue a written statement certifying approval of the flooring which is to withstand the intended loads
- it must be ascertained that there are no pipelines, sewage systems or any other underground cavities that can result in the base unit giving way and/or sinking, at no point in time during the operational life of the machine
- suitable power supply, which is in accordance with the regulations, is to be organized together with the earthing system

### 8.8.3 Shearing risk deriving from machine proximity to obstacles

When the machine moves within the required distance from any obstacles depending on the installation type, a risk is present of shearing for people on board the machine or present on structures adjacent to the machine path. By obstacle it means any object which is protruding towards the machine path to a distance below the required distance from it (trees, streetlamps, suspended cables, terraces floor slabs, steel beams, etc.).

Possible risks:

- shearing risk / trapping hazard for people moving on buildings or structures adjacent to machine elevation path
- shearing risk for people on board machine

Prevention and safety measures:

- wherever possible, maintain the maximum required distance from machine to any obstacle near its elevation path

#### 8.8.4 Risks arising from transporting the machine

The machine and its accessories are unloaded. The material is set according to the position chosen for the assembly operation.

For this operation, all the documents pertaining to the configuration together with the Use and Maintenance Instruction Manual of the machine must be consulted. Moreover, all the necessary means must be employed for lifting and transporting the material in question.

Possible risks:

- breakages or damages to the material
- instability of the material when deposited in piles
- errors in the material or configuration to be installed
- personnel knocking, pinching, or shearing limbs
- personnel suffering from trauma due to exertion

Prevention and safety measures:

- the person responsible for the installation must see to inspecting the components to verify their structural integrity
- the stability of the material piled up must be ascertained to prevent it from giving way or slipping
- the person responsible for the installation must verify that the required components for the configuration to be installed are prepared accordingly, paying attention to components that could create confusion due to their similarity with others
- all loads that are to be mechanically moved must be adequately strapped with adjustable cables, belts or chains. Only one operator must be responsible for signaling the required maneuvers to the operator driving the un/loading vehicle and he must use regulatory signs. Personnel not involved in this operation will remain at a safe distance. Nobody must pass under or stop beneath suspended loads, and the area in question must be closed off and marked
- the personnel designated to manually move the material must be informed of the weight of each component and the best way to handle it

#### 8.8.5 Risks arising from incorrect assembly on the ground

The first components of the vertical mast, wall anchors and the frames of the electric cable guide are assembled.

For this operation, all the documents pertaining to the configuration together with the Use and Maintenance Instruction Manual of the machine must be consulted. Moreover, all the necessary means must be employed for lifting and transporting the material in question.

Possible risks:

- errors in the assembly process
- assembly is not compliant with the authorization given
- falling material or equipment
- errors in the electrical connections

Prevention and safety measures:

- all personnel designated to the assembly process must be qualified and must be perfectly aware of the procedures given in the Instruction Manual of the machine. Attention is to be paid to when positioning and fastening each component precisely whilst carefully following the indications of the Instruction Manual
- during the installation process, exact correspondence must be verified between the work carried out, the assembly layout given with the authorization and that of the Instruction Manual
- personnel involved in the installation operations must constantly wear safety hard hat, safety shoes and work gloves. Nobody is to be allowed to stop beneath or pass under the machine during the assembly process
- all electrical connections must be carried out exclusively by qualified personnel and their functionality is to be verified before being used

#### 8.8.6 Risks arising from incorrect overground assembly

The machine's vertical masts are assembled, and the relative wall anchors are implemented with the relative protruding sections, which are necessary for fastening the masts. For this operation, all the documents pertaining to the configuration together with the Use and Maintenance Instruction Manual of the machine must be consulted. Moreover, all the necessary means must be employed for mounting the masts and anchors.

Possible risks:

- errors in the assembly process
- assembly is not compliant with the authorization given
- falling material or equipment
- defects in implementing the wall anchors
- personnel shearing limbs
- obstructions in the machine's path
- incorrect positioning of the end-of-travel

Prevention and safety measures:

- All personnel designated for the assembly process must be qualified and must be perfectly aware of the procedures given in the Instruction Manual of the machine. Attention is to be paid when positioning and fastening each component precisely whilst carefully following the indications of the Instruction Manual
- during the installation process, exact correspondence must be verified between the work carried out, the assembly layout given with authorization and that of the Instruction Manual
- personnel involved in the installation operations must constantly wear safety hats, safety shoes and work gloves. Nobody is to be allowed to stop beneath or pass under the machine during the assembly process
- All the anchors must be implemented in accordance with the instructions given by the person responsible for the installation process. If an anchor seems to be inadequate, the works in progress must be put on hold and the situation is to be reported to the person responsible for the installation process
- only one operator is to handle the movement of the machine. The operator will carry out each maneuver only after having ascertained the position of all the other operators, who must remain in their safe positions. Before putting the machine in motion, all objects placed on the machine must be secured to prevent them interfering with the maneuvers or possibly falling
- when the machine is in motion, utmost care must be taken to avoid a member of staff from being crushed under the protruding parts
- when the machine is in motion, utmost care must be taken to ensure that the machine's path is not somehow obstructed
- the safety end-of-travel devices must be positioned in such a way to let the machine work between two adequate heights, whilst preventing an impact with the base unit and also preventing the upward movement going beyond the upper limit of the mast

#### 8.8.7 Risks arising from functional verification of the machine

The correct functionality of all the machine's driving and safety devices is verified together with the correct movement of the machine itself.

For this operation, all the documents pertaining to the configuration together with the Use and Maintenance Instruction Manual of the machine must be consulted.

Possible risks:

- errors in the assembly process or in the electrical connection
- falling material or equipment
- incorrect adjustment for the downward motion of the machine

Prevention and safety measures:

- all personnel designated to the assembly process must be qualified and must be perfectly aware of the procedures given in the Instruction Manual of the machine. All the functions of the normal drive must be verified, starting from the simpler operations, and proceeding onto the more complex ones
- if, for any reason whatsoever, difficulties arise in completing the functional test when driving the cabin downwards and it is considered to be further complicated to drive the cabin down to the ground, the designated personnel will immediately suspend the test. The personnel must ensure their safety by fastening the safety-belt's spring-clip to the fall protection rope, which will be connected to an appropriate structural part of the building. The safety manager must be informed and under his supervision, the personnel are to be evacuated from the cabin with the help of qualified personnel

#### 8.8.8 Risks arising from the machine's normal operation

The machine is used for normal operations in the construction site.

For this operation, the Use and Maintenance Instruction Manual of the machine must be consulted.

Possible risks:

- the machine is overloaded
- personnel, material or equipment fall when work is being carried out
- the machine stops working due to a power failure
- a wall anchor loosens
- the machine stops working due to a failure in the lifting unit

Prevention and safety measures:

- all personnel designated to the machine's functionality must be qualified and must be perfectly aware of the procedures given in the Instruction Manual of the machine. The site manager must supervise the loading operations, ensuring not to overload the machine
- the personnel must take care to remain inside the cabin and must never use ladders, provisional bridges or any other device to reach a higher level or protruding part
- if a power failure occurs, the safety manager must be immediately informed, and he will see to organizing the necessary interventions to restore the working conditions. The personnel onboard must remain safe and must not implement any improvised maneuver. If it is not possible to resolve the problem promptly, the personnel must follow the procedures given in the Instruction Manual to descend the machine manually
- the wall anchors must be checked periodically, especially after particularly intense weather conditions, under the supervision of the safety manager. If an anchor is found to be loose, all personnel must be evacuated from the cabin, and a new wall anchor must be implemented
- if a failure is verified in the lifting unit, the safety manager must be informed and under his supervision, all personnel must be evacuated from the cabin, and the defect is to be repaired by the maintenance personnel or by BETA MAX Technical Support

### 8.8.9 Risks arising from descending the machine manually

The machine is driven to the ground floor level or to the closest landing platform following a failure in the lifting unit.

For this operation, the Use and Maintenance Instruction Manual of the machine must be consulted.

Possible risks:

- intervention of the safety brake device
- the motor brakes overheat
- unusual wear and tear of the motor brakes
- impact between the loading unit and the base unit if the machine is driven to ground level

Prevention and safety measures:

- implement the manual descent maneuver by meticulously following the indications given in Chapter 9, Section 9.4 *“Manual descent procedure”* in this manual
- it is prohibited to provoke the intervention of the safety brake device for the cabin to gain speed.
- In fact, should this occur, it will not be possible to operate the machine unless qualified personnel from BETA MAX Technical Support intervenes
- you are to absolutely avoid driving the cabin downwards for long distances as the motor brakes can overheat and/or wear out. In fact, should this occur, the machine could start going down uncontrollably, resulting in the safety brake device intervening, after which it will not be possible to operate the machine unless qualified personnel from BETA MAX Technical Support intervenes
- if the cabin is driven right down to the ground floor, the operator must pay utmost attention in not bringing it down too fast as this impact with the base unit’s shock absorbers could cause damage to the machine itself or injure the operator

#### 8.8.10 Risks arising from handling the machine in the construction site

With the use of lifting equipment, the machine is moved from one area to another, within the same construction site where it has been installed.

For this operation, the Use and Maintenance Instruction Manual of the machine must be consulted. Moreover, all necessary measures must be taken to eliminate the risks arising from the lifting process of the machine.

Possible risks:

- inadequacy of the lifting equipment
- inadequate positioning

Prevention and safety measures:

- always ensure that the lifting equipment used is able to lift the machine within a large margin of safety
- to handle the machine, always position the lifting blades or the anchor cables as described in this instruction manual, in order not to damage the machine's structure
- always check the adequacy of the supporting surface onto which the machine is to be repositioned and carry out the re-assembly operations of all the service and anchor structure on the building in question, in accordance with all that stipulated in this instruction manual

#### 8.8.11 Risks arising from disassembling the machine

The machine's vertical masts are disassembled together with the relative wall anchors.

For this operation, the Use and Maintenance Instruction Manual of the machine must be consulted. Moreover, all necessary measures must be taken for the disassembly of the masts and anchors.

Possible risks:

- instability of the disassembled components
- instability of the machine
- personnel, material or equipment fall when work is being carried out

Prevention and safety measures:

- pay particular attention when positioning the disassembled components, always following the indications given in the Instruction Manual, precisely
- disassemble the anchors at the same pace as the mast's vertical components so as not to cause instability to the machine
- personnel must take care to remain inside the parapets on the upper part of the loading unit and within the perimeter of the mounting platform; they must also never use ladders or provisional bridges to reach the wall anchors. Everyone must be prohibited from passing under or stopping below the cabin and the said area must be properly enclosed



**This page has been left blank for formatting purposes**

# CHAPTER 9: PREPARATION FOR MACHINE USE

Record of modifications

Revision	Executor	Date	Description of modification

## **9 PREPARATION FOR MACHINE USE**

### **9.1 SAFETY REQUIREMENTS BEFORE HANDLING THE MACHINE**

Once the machine is mounted and the electrical connection is set, it is good practice to carry out several verifications to ascertain its functionality.

Before handling the machine verify that:

- the base enclosure has been mounted correctly, preventing anyone from stepping into or stopping inside the area where the loading unit descends
- adequate signs, which are easily visible and/or bright, have been set in place
- there are no power lines in the machine's path or in its immediate vicinity, which can constitute a risk for the operator's safety
- there is no material nor protruding components in the machine's path, which can hit the workers or hinder the machine's regular movement
- all the machine's mechanical, electromechanical, and electrical safety devices work perfectly well
- the rack, pinions and sliding wheels are in perfect working condition
- the belts used in any emergency are readily available on the machine (where required from the operation plans of the site)
- when the cabin is driven upward or downward, the personnel onboard are positioned in such a way to spread the load in a uniform manner
- the emergency brake control, which triggers the interruption of the entire control circuit, immediately stopping the machine's movements, works perfectly well
- the wind speed is less than 44 mph otherwise the cabin must be brought down
- in case of a power failure, the cabin can be brought down to the ground level by acting upon the lever of the manual release of the motor brakes, very cautiously. The operation must be carried out by BETA MAX Technical Support personnel or by specialized personnel, specially trained in maintenance and repairs
- there is no snow or ice on the machine, otherwise it is obligatory to see that this is removed
- the drive direction of the machine is in accordance with the pressed drive button
- after having carried out the trial run, all the upward/downward brake devices function correctly

After having carried out the verifications described above, the machine is ready for its normal operation in a construction site.

## 9.2 SAFETY REQUIREMENTS DURING MACHINE OPERATION

To work safely, always remember the following requirements during machine operation:

- it is strictly forbidden to construct work levels which are higher than the loading unit
- when the loading unit is elevated, the machine can only be abandoned in the case of an emergency and making use of the appropriate fall protection devices
- the cabin is to be brought down to ground level, as soon as possible, in every instance and any kind of failure

### **DANGER:**

When failure occurs during machine operation, take the necessary steps to resolve this before utilizing the machine again.

- at the end of each working day, the cabin must be brought down to its lowest position and the power supply must be disconnected, storing the power cable separately, in a safe place.

## 9.3 SAFETY VERIFICATION INSTRUCTIONS

The Technicians, who are responsible for the machine's start up and maintenance, are to refer to the instructions given below in order to verify the functionality of the installed safety devices and to ensure that all parts of the machine work perfectly well. These instructions are also found in abbreviated form on the labels onboard the machine.

### 9.3.1 General verification of the machine

To ensure that the machine's mechanical components are working perfectly well, proceed as described below:

- in case of a storm, tornado, hurricane or earthquake, all essential parts of the machine must be checked by a professional or an authorized inspector, before putting the machine back into operation
- if the machine is installed outdoors, it must not be used if the wind speed exceeds 44 mph
- if the machine is exposed to frost, the cabin must be brought down to the landing floor level, once the work is carried out. If the mast and/or the power cable are covered in ice, remove this before operating the machine
- ensure that no equipment or material is suspended from the machine's structure

### **DANGER:**

It is strictly forbidden to suspend any equipment or material from the machine's lifting structure.

### **ATTENTION:**

A safety inspection must be carried out every day or every shift before operating the machine.

### 9.3.2 Electrical verification of the machine

To test and ascertain that the electrical command and control devices work perfectly well, proceed as described below:

- check that all the emergency buttons and main switches of electric boards, function properly. For this purpose, carry out trial runs with each EMERGENCY buttons pushed, and each switch set to the “0” position. In all instances the machine must not move
- verify synchronization by carrying out trial runs with the base enclosure doors and the floor level doors open. In all instances the machine must not move

#### **NOTE:**

Carry out the verification tests with one switch at a time to clearly identify any malfunctions.

- perform trial runs to verify the functionality of the end-of-travel devices
- also check that the pads and the end-of-travel devices are fastened well

### 9.3.3 Verification of the machine’s motion

To test the cabin’s motion, proceed as described below:

- visually check the machine’s cable guide and ensure that it is free from any obstacle. Monitor this constantly
- while the loading unit is on the ground level, turn the main switches of base and onboard control panel to the “1” position
- ensure that the load does not exceed the maximum allowed - refer to the information given on the label indicating the load capacity
- close the floor level doors, the base enclosure door, and the access ramps to loading unit properly
- press the pushbutton to drive the loading unit in the desired direction and the machine will start-up. At the extreme floor levels the cabin will automatically stop by means of the end-of-travel cams placed on the mast. During travel, press the STOP NEXT LANDING pushbutton when the machine approaches the floor chosen for the landing to see if it shuts down automatically

#### **DANGER:**

An approximate assessment of the operating conditions is the greatest and most common cause of accidents, often with a fatal outcome.

## 9.4 MANUAL DESCENT PROCEDURE

When the machine is in use, if a failure occurs in the lifting unit while it is at height, the manual descent procedure must be implemented until the personnel onboard can get out onto a floor level or the machine reaches a safe height.

To implement this operation, proceed as described below:

- the main switch of the onboard control panel must be set to the “OFF” position.
- remove the manual decent panel located directly below the on-board control panel.
- act upon the manual release lever (1) to the right.
- act upon the lever with extreme caution and very lightly for a short while, for the cabin to start descending without gaining speed.
- stop after a short distance is covered so that the brake can cool down properly; this prevents the brake lining from overheating and burning out, resulting in speed control being lost and the lifting unit dropping downwards. As an example, the operator can cover a distance of about 10 ft, equal to two masts, and must then let the brake cool down for about 1 minute.

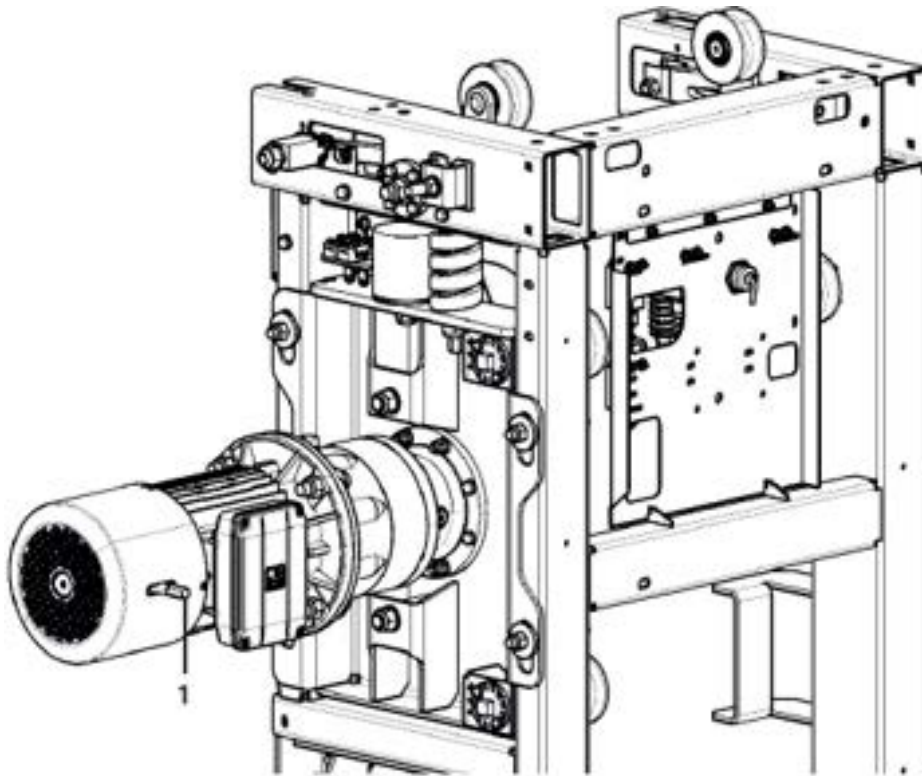

Figure 9.1

**ATTENTION:**

If the machine gains too much speed during the manual descent procedure, resulting in the lifting unit free-falling, the safety brake device will intervene. In this case, the machine cannot be handled without the intervention of qualified personnel from BETA MAX's technical support.

- as soon as the lifting unit reaches a floor level where the personnel onboard can get off, the machine must be stopped and abandoned. Bringing the cabin back to ground floor level or carrying out the necessary repairs over ground is a task which is to be carried out by the personnel from BETA MAX Technical Support or qualified personnel appropriately trained in maintenance and repairs

#### 9.4.1 General regulations to descend manually but safely

Members of staff, who are given the responsibility of descending the machine manually, must be appropriately and particularly prepared and all operators concerned with this procedure must always keep the following safety warnings in mind.

### **ATTENTION:**

If it is not possible to carry out the manual descent procedure, remain on the machine and call the safety manager, for all persons and material to be evacuated with suitable means.

### **DANGER:**

Releasing the brake for the machine to descend, is a task which is to be carried out by personnel from BETA MAX technical support or qualified personnel who are appropriately trained in maintenance and repairs. The persons designated to work on the machine, which happens to be at altitude when the failure occurs must limit themselves to driving the cabin down, by means of the brake release, solely till a floor level is reached where they can get off or until the machine reaches a safe condition.

### **DANGER:**

Implement the brake release maneuver for very short distances, at a maximum speed equal to 1/3 of the normal working speed. Moreover, when this maneuver is carried out, it is necessary to stop for at least 1 minute every 20 seconds of descent so that the brakes can cool down. It is very important to implement this procedure because if the brakes overheat, this could put the entire braking system at risk with very serious consequences.

## 9.5 OPERATING THE MACHINE

Operators who are appropriately trained can operate the machine.

Once all the verifications have been carried out on the machine by qualified Technicians who are responsible for the construction site, proceed as described below:

- the main switch of the base and onboard control panel must be set to the “1” position
- to position the cabin over ground, drive it in the desired direction and once the floor level is reached, press the emergency pushbutton as an additional safety

### **ATTENTION:**

Before utilizing the machine in any way, all safety procedures must be implemented, and maintenance and lubrication procedures must be carried out as stipulated in the relative chapter of this manual.

### **DANGER:**

It is strictly forbidden to enter the base enclosure or stop beneath the machine’s path when this is in operation.

## 9.6 OPENING OF GATES FOR EGRESS TO BUILDING

Whenever egressing the work platform to a building floor equipped with suitable access/egress gate, it is necessary to open the provided safety railings in accordance with the following procedure:

- open the ramp on board the machine
- ensure that the dock-leveler is correctly positioned on the access gate, to create a safe passage between machine and access gate on the building
- open the gate placed on the floor of the served building

### **DANGER:**

It is strictly forbidden to open the gate on the building side without first deploying the ramp on the machine side.

## **9.7 SHUTTING DOWN THE MACHINE AT THE END OF A WORK SHIFT**

Once a work shift is over, proceed as described below to shut down the machine:

- drive the cabin to the ground floor level until it stops at the lower end-of-travel device.  
Put the main switch of the base and onboard control panel in position “OFF”.  
Disconnect the machine from the power supply. Ensure that nobody has access to the machinery when there is no personnel present who is responsible for the said machinery.

## **9.8 SHUTTING DOWN THE MACHINE FOR LONG PERIODS**

To shut down the machine for long periods of time, proceed as described below:

- carry out the procedures explained for the end of a work shift. In case of ice, snow or heavy rain, before putting the machine back into operation, ensure that the integrity of the delicate parts has not been altered. Leaving the machine idle for a long period of time can cause some trouble such as, the motor brakes can lock, metal parts and gaskets can corrode.



**This page has been left blank for formatting purposes**

## CHAPTER 10: TROUBLESHOOTING

Record of modifications

Revision	Executor	Date	Description of modification

## 10 TROUBLESHOOTING

### 10.1 THE MACHINE DOES NOT START

If the machine does not start up, the operator responsible for its maintenance must:

- ensure that the main switches of the base and onboard control panels are in the “OFF” position.
- ensure that none of the EMERGENCY pushbuttons are depressed.
- ensure that the platforms for mounting the anchors, all the access doors and the floor level doors are closed properly.
- ensure that no switch has interrupted the power supply.
- ensure that no alarm light is lit on electrical panels.
- ensure that the safety brake device is not intervened.

If the machine still does not start up after having verified or restored all these conditions, call Beta Max technical support.

### 10.2 THE MACHINE STOPS ABRUPTLY

If the machine stops between two floor levels due to a power failure, a blown fuse or a switch having interrupted the power supply due to a power surge, etc., it can be manually lowered to the nearest floor landing.

To move the machine to the nearest landing floor, proceed as shown in Chapter 9, Section 9.4 “*Manual descent procedure*” of the present instruction manual.

If, for any reason, it is not possible to lower the cabin, remain inside the loading unit and call Beta Max Technical support.

#### **ATTENTION:**

**If the machine's movement is blocked, call for technical assistance.  
Remain inside the machine until qualified personnel arrive.**

## 10.3 ELECTRIC MOTORS TROUBLESHOOTING

To maintain the electric motors efficiently you must service them correctly as described in the relevant section of this manual.

Malfunction:

- the motor is too hot (this can only be established after carrying out the relative verification)

Probable cause:

- the motor connection does not comply with the supply voltage
- the supply voltage variation is more than the motor's rated voltage. Higher voltage is particularly unfavorable for high-polarity motors as their rated values reach absorption with a normal voltage
- lack of cooling air caused by clogged air passages
- the cooling air is heated
- overload, with a normal voltage, high absorption, and low speed
- weak power cable contact (gear is temporarily on one phase)

Remedy:

- modify the connection
- ensure the correct voltage is supplied
- ensure that there is good air circulation
- add on cool air
- eliminate the machine's overload
- ensure the clamps convey good contact

Malfunction:

- the motor does not start up easily or does not start up at all

Probable cause:

- blown fuse
- the contactor has interrupted the power supply
- the motor's contactor does not respond due to a fault in the command
- the motor is set to start-up with a triangular connection but is connected to a star connection
- the voltage or frequency drops considerably in respect to their rated value
- the star-triangle switch has weak contact

Remedy:

- replace the blown fuse
- verify and adjust the contactor
- verify the contactor's command and eliminate the cause of the malfunction
- correct the connection
- improve the power supply
- repair the contact

Apart from the above-mentioned verifications and inspections, check and if necessary adjust the air gap as described in the following paragraph.



**This page has been left blank for formatting purposes**

# CHAPTER 11: MAINTENANCE AND REPAIR

Record of modifications

Revision	Executor	Date	Description of modification

## 11 MAINTENANCE AND REPAIR

### 11.1 GENERAL INSTRUCTIONS

Regular maintenance of the mechanical and electrical components prolongs the machine's operational life, ensures best performance and is an important safety factor. Regularly verify the efficacy of the devices installed on the machine, in accordance with the indications given in this instruction manual.

Only specialized and authorized personnel are to carry out any maintenance or repairs on the electrical system.

The operator responsible for maintenance must remember the following:

- always use individual protection gear (gloves, earmuffs, safety shoes, goggles) when carrying out maintenance operations on the machine
- never start works on the machine before having interrupted all electrical power supply and ensuring that nobody can reconnect it, even inadvertently
- never to intervene on the machine by operating from under the work platform: all maintenance operations shall be carried out from the upper surface of the work platform or, with the machine resting on the ground, from outside the work platform perimeter
- only original spare parts are to be used whenever maintenance and repairs are carried out on the machine
- if the machine is shut down due to faults, maintenance, or repairs, this must be made known by means of a warning sign
- once maintenance or repairs are carried out, ensure that no tools or items have been left inside the machine or in the loading unit
- the machine's devices are to be checked and tested in accordance with the stipulated regularity
- after having carried out maintenance operations, these must always be recorded in the appropriate register that is attached to this manual

#### **ATTENTION:**

**If maintenance is not carried out in accordance with the above-mentioned instructions, or not in conformity with that stipulated in this manual, it will be considered as improper use. BETA MAX disclaims all responsibility if the operator fails to comply with the requirements.**

#### **ATTENTION:**

**For repairs to be carried out, it is recommended to always contact authorized technical support or the Manufacturer of the machine. If maintenance and repairs are carried out incorrectly, without original spare parts or by personnel who is not specialized and authorized, the user of the machine bears full responsibility for its proper use.**

## 11.2 MAINTENANCE SCHEDULE

Maintenance operations must be performed with the following timetable:

Maintenance every	<b>Daily</b>	it does not include the obligation to register the maintenance schedules
Maintenance every	<b>40 hours</b>	it does not include the obligation to register the maintenance schedules
Maintenance every	<b>125 hours</b>	it includes the obligation to register the maintenance schedules
Maintenance every	<b>500 hours</b>	it includes the obligation to register the maintenance schedules

Maintenance operations to perform according to the working hours of the machine are described in detail in the following paragraphs. The corresponding forms to be filled are attached to this manual.

### ATTENTION:

To verify the periodic maintenance operations due, refer to the meter installed on the electrical control panel. This is the most reliable instrument to verify the machine's operational life, which in turn lets you check the operating time that has elapsed in between maintenance operations.

### ATTENTION:

It is not obligatory for the maintenance operations, which are to be carried out Daily or every 40 and 120 hours, to be recorded in the maintenance register.

However, it is obligatory for the maintenance operations, which are to be carried out every 500 hours, to be recorded in the maintenance register.

### ATTENTION:

If the machine remains installed for long periods of time, even if it is not used, maintenance must be carried out every three months. This maintenance operation is to be carried out in the same way as the one due after 500 hours. If this is not carried out at the end of the three months, it is **OBLIGATORY** to carry out this maintenance operation when the machine is put back into operation. It is not obligatory for this intervention to be recorded in the maintenance register.

### 11.2.1 General maintenance (Daily)

Perform the maintenance described below:

- check for fallen hardware in pit/surrounding area (ex. mast bolts, cable guides, construction material)
- check hoistway for obstructions
- ensure that ice is not present on the mast or trailing cable (must be removed before operation)
- in case of intense weather conditions prior to operation, all essential parts of machine must be inspected
- ensure wind speeds do not exceed safe operating conditions
- check grease level in automatic greaser
- check for any signs of oil leaks around gearbox and motor
- check the base and loading unit for damage
- check that all hoists' guards are in place (ex. mast guard, wall panels)
- check emergency stop pushbuttons and main switches
- perform trial runs with emergency stop pushbuttons engaged to verify functionality
- perform trial runs with car door/ramp open to verify unit does not run
- check that the controls are functioning and are undamaged
- perform a trial run to verify motor and motor brake is functioning
- perform a trial run to verify the travel down stop is functioning
- check the mast sections for missing or loose hardware
- check wall anchors for missing or loose hardware
- check cable guides for missing or loose hardware
- check cable guides for missing cable keepers
- check the trailing cable ensuring all of the cable is spooled into the cable drum
- ensure the trailing cable is not damaged in any way
- perform a trial run to verify the travel up stop is functioning
- perform a trial run to verify the floor stops are functioning

The General Maintenance (Daily) checklist form is located in appendix C of this manual.

### 11.2.2 General maintenance (40 hours)

Perform the maintenance described below:

- check for fallen hardware in the pit/surrounding area (ex. mast bolts, cable guides, construction material)
- check hoistway for obstructions
- ensure that ice is not present on the mast or trailing cable (must be removed before operation)
- ensure wind speeds do not exceed safe operating conditions
- check the support conditions of the base frame
- ensure that all warning signs are legible and in the right place
- ensure that all documents are readily available and legible
- check the oil level of the gearbox
- lubricate the pinion shaft of the safety device through the proper greases nipple
- lubricate the indicated parts paying particular attention to the rack
- check the grease level of the automatic greaser
- ensure all connections of the guide rollers to the machine's frame are correct and tight
- check the rack of the mast and the motor pinion and ensure there is no damage, alignment errors, or defective connections
- ensure that the electric motor brake functions properly, the loading unit must stop within the set limits when the brake is applied
- inspect all bolted joints between the components of the mast
- inspect all bolted joints of the wall anchors
- inspect the cable guides and check for missing cable keepers
- check the emergency stop pushbuttons and main switches
- check that the controls are functioning and are undamaged
- perform trial runs with the emergency stop pushbuttons engaged to verify functionality
- check the functionality of the manual release mechanism of the brakes checking for damage
- verify the operation of the final travel stops
- ensure that all mechanical and electrical synchronized systems function properly – both on the machine and on the floor levels
- check the trailing cable and ensure that this is not damaged, twisted, or pinched in any way
- check the trailing cable ensuring all of the cable is spooling correctly in the drum
- ensure that the safety device does not intervene unnecessarily and does not make noise
- (if applicable) check the loading unit roof installation and attachment
- check the functionality of the overweight sensor system

The General Maintenance (40 hour) checklist form is located in appendix D of this manual.

### 11.2.3 General maintenance (125 hours)

In addition to the controls concerning the maintenance of the 40 h, perform the maintenance described below:

- tighten all bolted joints between the components of the mast
- tighten all bolted joints of the wall anchors
- tighten the cable guides and check for missing cable keepers
- clean any debris from the covers of the electric motor and fan

The General Maintenance (125 hour) checklist form is located in appendix E of this manual.

### 11.2.4 General maintenance (500 hours)

In addition to the controls concerning the maintenance of the 125 h, perform the maintenance described below:

- check the state of preservation of the base frame
- check the state of preservation of the loading unit and doors/ramps
- check the state of preservation of the lifting unit
- check the state of preservation of the electrical panels
- check the state of preservation of the landing door/gate
- perform a drop test of the unit

Contact Beta Max technical support for inspection and any repairs.

The General Maintenance (500 hour) checklist form is located in appendix F of this manual.

### 11.3 FUNDAMENTAL MAINTENANCE OPERATIONS

The machine's main operations of inspection, verification and lubrication, recommended for all the maintenance operations mentioned above, can be carried out correctly by following the indications given below:

- verification of the lifting unit's pinions
- verification of the lifting unit's drive system
- wear and tear verification of the lifting unit's drive wheels
- inspection of the rack and the vertical components
- servicing the electric motors
- verification and adjustment of the air gap of the motor brakes
- servicing the gear motors
- lubricating the machine

### 11.3.1 Verification of the lifting unit's pinions

To check the wear and tear of the pinions and pulleys (if present) of the lifting unit, proceed as described below:

- drive the cabin to the shutdown position on the ground floor level and disconnect the electrical control panel from the power line
- from the rear end of the lifting unit, visually check and ensure that the teeth of each pinion and pulley (if present) are not damaged, and the tangent length is not less than that specified below

**Motor pinion (1) with a minimum tangent length of 35.5 mm (1.3976 in)**

**Pulley (2) with a minimum tangent length of 60.5 mm (2.3818 in)**

**Safety brake pinion (3) with a minimum tangent length of 35.5 mm (1.3976 in)**

- if damages are found or the measurements do not fall within the limits indicated, replace the worn-out component
- put the machine back on

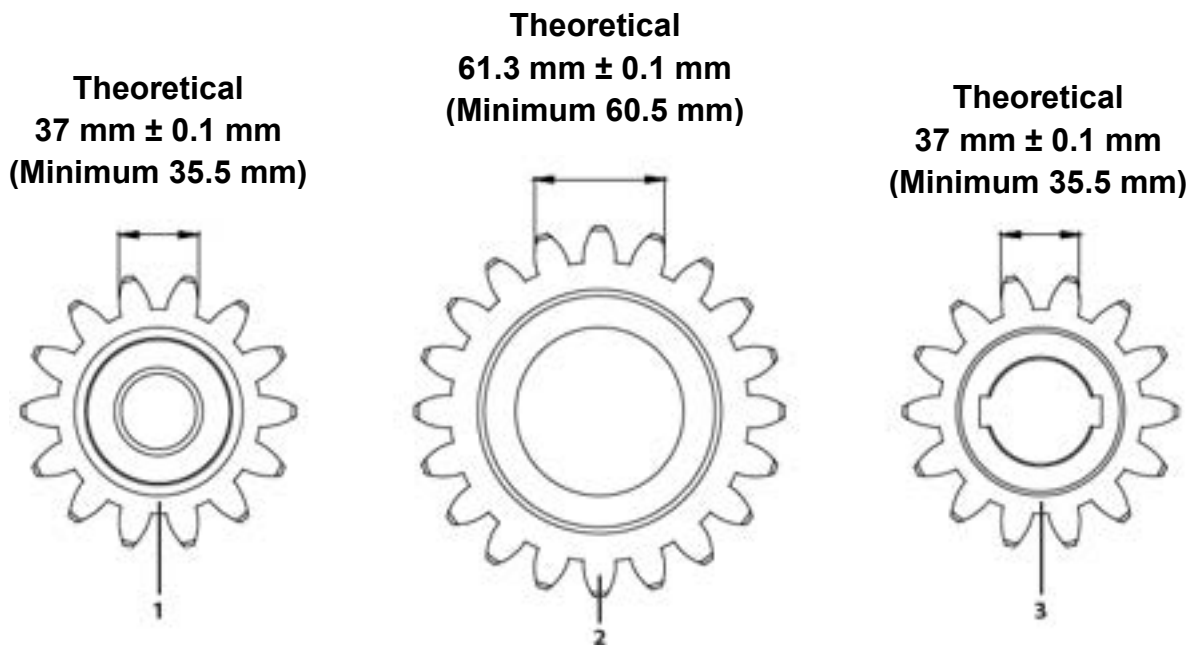

Figure 11.1

### 11.3.2 Verification of the lifting unit's drive system

To verify that the lifting unit's drive system is properly adjusted, proceed as described below:

- drive the cabin to the shutdown position on the ground floor level and disconnect the electrical control panel from the power line
- from the rear end of the lifting unit, ensure that the drive wheels (1) and (2) and the bevel wheels (3) are fitted well on the bars and on the rack of the vertical component, and the pinions and pulleys (if present) engage well with the rack as shown in the figure below
- the pinions and pulleys must remain centered on the rack as shown in the figure below, so that the teeth engage perfectly well with the rack
- check that any loosening between the upper and lower drive wheels of the unit fall within the limits shown in the figure below, in respect to the bars of the vertical component and the rack. The wheels are grouped in carriages that allow a necessary oscillation when sliding and can be adjusted for the loosening effect to be about 1mm (0.039 in).
- if the wheels are not in the recommended condition, adjust them by positioning the bevel wheels (3) in contact on the rack side (4).
- Loosen the locking screw (5) and act upon the eccentric pin (6) till bringing the wheel in contact, then tighten the locking screw once again (5). Should the engagement position of the pinion on the rack be lost due to the adjustment operation, adjust the position of the drive wheels (1) following the same procedure described for the bevel wheels, in order to not stress the mast upright too much.
- put the machine back on

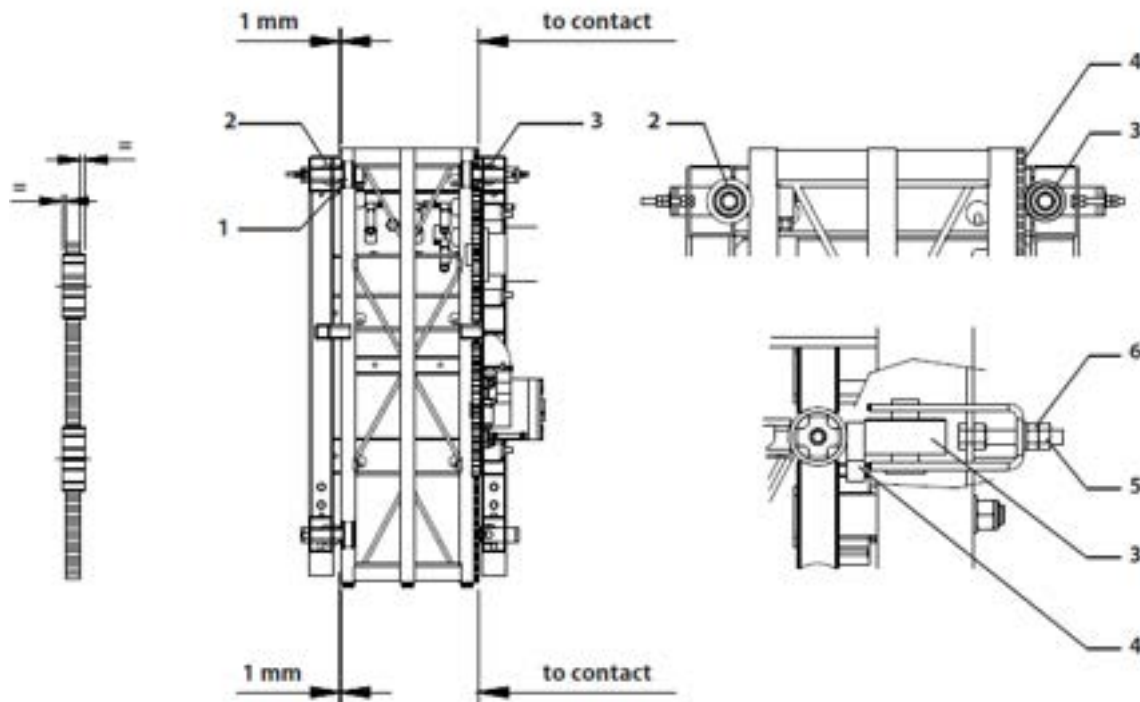

Figure 11.2

### 11.3.3 Wear and tear verification of the lifting unit's drive wheels

To check the wear and tear of the lifting unit's drive wheels proceed as described below:

- drive the cabin to the shutdown position on the ground floor level and disconnect the electrical control panel from the power line
- from the rear end of the lifting unit, visually check and ensure that each drive wheel is not damaged or excessively worn out, as shown in figure; this is to be checked all along the surface where they are in contact with the bar of the vertical component
- if the wheels are found damaged or worn out, replace them and verify the loosening effect between the wheels and the bar of the vertical component, as described earlier on
- put the machine back on

### 11.3.4 Inspection of the rack and the vertical components

To check the wear and tear of the rack and the vertical components proceed as described below:

- with the machine in regular operation mode, set the operation mode selector of the control panel to the "TP" position so that the machine can be solely controlled by the operator responsible for the maintenance
- from the upper part of the loading unit, the maintenance technician must visually check the rack and bars where the drive wheels' rest on each component of the vertical mast, whilst controlling the upward movement of the lifting unit
- Other than this visual inspection, the maintenance technician must measure the rack's wear and tear by placing a calibrated roller with  $\varnothing 15$  h8 in various parts of the vertical mast as shown in figure. The same measurement inspection must be carried out in all the parts that are worn out

#### Rack with a minimum measurement of 53.2 mm (2.094 in)

- if they are found damaged or the measurements do not fall within the limits indicated, replace the vertical mast
- put the machine back on

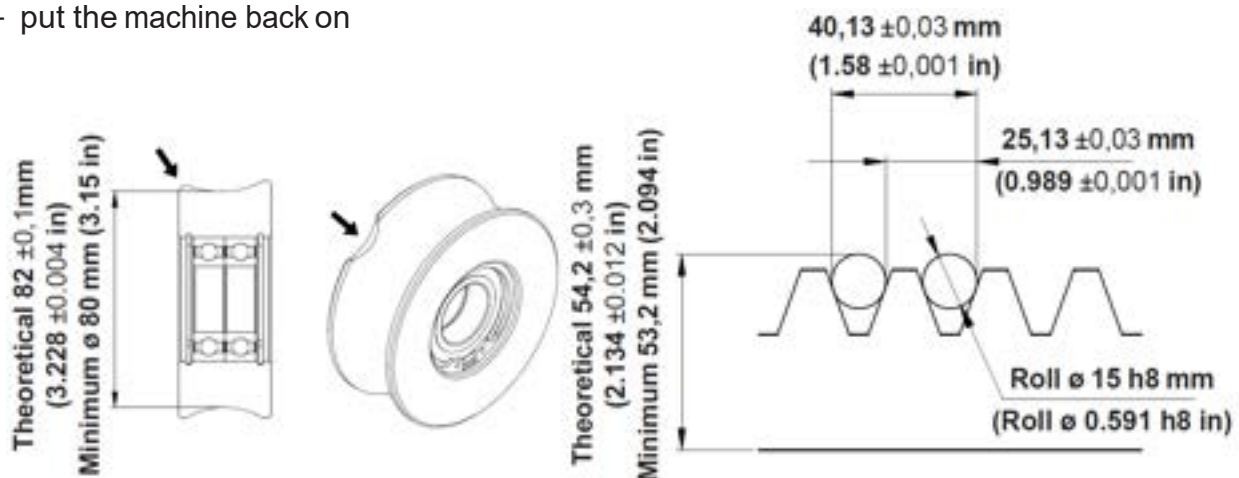

Figure 11.3

### 11.3.5 Verification and adjustment of the air gap of the motor brakes

The air gap (1) is the distance between the two nuclei of the electromagnet; one of which is set on the mobile anchor (2) of the device. To avoid vibrations on the anchor itself, excessive noise, the electromagnet's coils from burning or the braking unit from being damaged, this distance must be between 0.3 and 0.4 mm. If the motor brake does not unlock or reaches its scheduled inspection, check the thickness of the brake lining and measure the air gap as described below:

- drive the cabin to the shutdown position on the ground floor level and disconnect the electrical
- control panel from the power line
- from the rear end of the lifting unit, remove the external protection covers (3) of the motor brakes after having removed the screws (4) and check the measurement of the brake lining (5) with a caliber and the measurement of the air gap (1) with a feeler gauge in each motor
- to adjust the measurement of the air gap (1) act upon the bolts (6) and (7) that set the electromagnet in place by making it move close to or away from the mobile anchor (2) of the device
- implement this adjustment on all the stud bolts of the spring system and finally verify that the distance of the air gap is uniform on all the circumference and that the bolts are tightened well
- put the external protection covers (3) back on, fixing them in place with the screws (4)
- put the machine back on

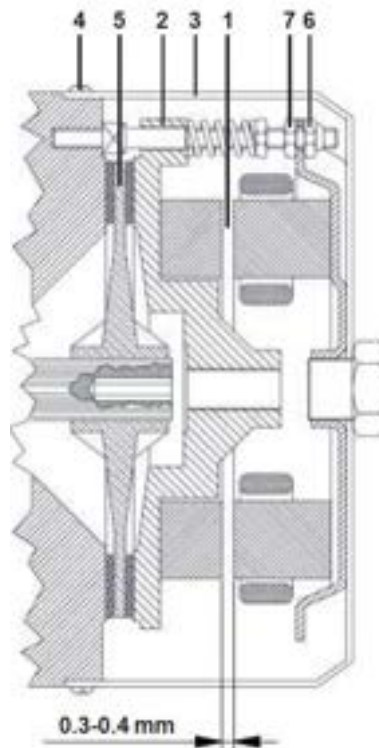

Figure 11.4

### 11.3.6 Servicing the gear motors

Servicing the gear motors installed on the machine simply requires the oil level to be checked - topping it up or replacing it if necessary, and in accordance with the schedules given below.

To carry out such operations proceed as described below:

- drive the cabin to the shutdown position on the ground floor level and disconnect the electrical control panel from the power line
- From the rear end of the lifting unit verify the oil level in each gear motor.
- If the gear motor is equipped with a sight glass (1) simply ensure that the oil reaches the sight glass itself; if the gear motor is not equipped with a sight glass but has a level plug (2), remove this and ensure that the oil reaches the plug hole. If the oil cannot be seen, use a clean rod which is quite flexible and insert it in the plug hole to have a good idea on the level of the oil
- unscrew the oil filler cap (3) and top up enough oil to reach the required level with SHELL OMALA oil 150 or its equivalent
- the level plug (2) and the filler cap are to be screwed back on (3)

### **ATTENTION:**

**To service the gear motors correctly, the oil must be completely replaced after the first 50-100 operating hours, then replaced after approximately 2500 operating hours and in any case, once a year and the oil level must be checked every 500 operating hours.**

Apart from the normal inspection of the oil level in accordance with the schedules given, the operator or authorized and qualified personnel will be responsible to carry out the maintenance, change the oil after the running-in period and replace all the oil in accordance with the stipulated schedule.

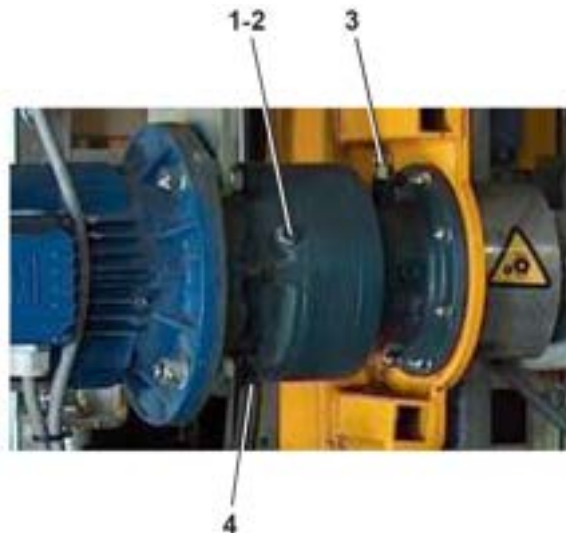

Figure 11.5

After about 50-100 operating hours, when the gear motor ends its running-in period, remove all the oil by removing the drain plug (4, fig. 11.5), wash the internal part well and refill the tank with new mineral oil in accordance with the table below. The successive oil replacement must be carried out after 2500 operating hours or after one year. With every replacement, it is always best to wash the internal part well.

Use lubricating oil which has an average ISO viscosity value of 150 CST at 40 °C

**ATTENTION:**

**For any top-ups of lubricating oil between one replacement and another, always use the same type of oil found inside the gear motor.**

**DANGER:**

**The oil must be replaced when the gear motor is hot, therefore you must be careful not to burn yourself during this operation.**

The lubricant that corresponds to the above-mentioned characteristics can be chosen from the listed below:

Producer	Type of Oil
API	DT 150
AGIP	BLASIA
ARAL	DEGOL B.G.
B.P.	ENERGOL GR/XP
ESSO	SPATAN EP
FIAT	E.P.Z.
IP	MELANA OIL
MOBIL	MOBILGEAR 600
SHELL	OMALA
TEXACO	MEROPA
TOTAL	CARTER EP

**ATTENTION:**

**It is absolutely prohibited to dispose of used oil in the environment.**

### 11.3.7 Lubricating the machine

The machine must be lubricated carefully, paying attention to the areas affected by the motor transmission, such as between the pinions, pulleys (if present) and the rack. Proceed as described below to lubricate the machine:

- From the rear end of the lifting unit, with the use of a brush, grease the pinions, the pulleys (if present) and the rack, which can be reached from the ground. The grease used for lubrication must be adequate for outdoor conditions
- start-up the machine and turn the control panel's operation mode selector to "TP" position so that the machine can be solely controlled by the operator who is responsible for maintenance
- from the loading unit, the maintenance technician must lubricate the various sections of the rack on each component of the vertical mast, as indicated earlier on, whilst controlling the upward movement of the lifting unit

#### **DANGER:**

**While carrying out the inspection and lubrication, be very careful not to place your hands near the motor transmission when the cabin is moved; the risk of having your limbs, and particularly your hands, pinched or sheared, is very evident.**

#### **ATTENTION:**

**The necessity to carry out the lubrication process depends on several factors, such as how frequent the machine is used, the type of use of the machine (transporting modest loads or operating often with a full load) and also weather conditions / the elements of the place where it is installed.**

**It is of fundamental importance that the pinions, pulleys (if presents) and rack are lubricated well to avoid excessive wear and tear on the motor transmission system and to have a smoother drive with little noise and without excessive vibrations.**

**The lubricating process must be carried out every time the machine's movement causes too much vibration and excessive noise, as it becomes a necessity in both instances, even if it is still early for the scheduled lubrication process to be carried out.**

#### **ATTENTION:**

**When on the machine is installed the mast automatic greasing device, the operator only needs to supply the grease into the container of the device before its empty.**

#### 11.3.8 Calibration of the OVERWEIGHT SENSOR system

The overweight sensor system needs to be inspected for proper functionality. It may be necessary to re-calibrate the system. To re-calibrate the overweight sensor system, follow the instructions located in appendix G of this manual.

For any other assistance contact Beta Max Technical Support.

## 11.4 TESTING THE SAFETY BRAKE DEVICE

### **ATTENTION:**

The drop test must be carried out upon every new installation and in conformity with local safety regulations that are in force. Moreover, this test must be carried out at least every 3 months with at least a full load.

If the safety device intervenes during normal downward operation, or if abnormal noise is emitted while the cabin is being driven, the machine must be stopped immediately, and BETA MAX technical support must be contacted.

### **DANGER:**

There must be nobody in the cabin when the drop test is carried out. Moreover, it is necessary to ensure that the brakes of the motors work well, as described earlier on.

### **DANGER:**

The drop test must be carried out solely by personnel who has been adequately prepared or by BETA MAX technical support.

Proceed as described below to carry out the drop test:

- set the MATERIALS/TP selector of the onboard control panel in the “TP” position.
- connect the control panel of the safety brake device to the electrical control panel.
- connect the cable to the electrical control panel, ensuring that the cable is suspended and that there is no risk of it being damaged during the drop test.
- If you take the test with the machine at full load, provide the load weight on the machine.
- close all the ramps of the machine, go outside of the ground enclosure or still in security location and make sure that the control cable test is free of obstacles
- Set the main switches on base control panel and on-board control panels to “ON” position.
- Using the drop test push button, drive the loading unit to a height of 30 ft.
- press the TEST button, this will release the electric motor brake, allowing the cabin to descend by gravity; when the cabin reaches a speed of about 98 ft/min, the safety brake will intervene, and the cabin will stop. If the safety brake does not intervene, let go the TEST button immediately; this causes the motor brake to intervene immediately.

---

---

## ATTENTION:

If the safety brake does not intervene because the cabin does not gain the required speed, let go the TEST button immediately; this causes the motor brake to intervene immediately, which in turn stops the cabin. Not letting go of the TEST button immediately, can cause a collision on the shock absorbing systems of the base unit.

## NOTE:

Keep the TEST button pressed until the safety brake intervenes; when the cabin is at a standstill, drive the cabin in the upward direction for a very short distance, by pressing the relative button for a very short while; this releases the safety brake system, which is used later for other resetting operations.

- act on the upward pushbutton on the TEST control panel, to drive the cabin in this direction for a short distance - this is to release the safety brake system
- act upon the TEST button for short instances to drive the machine to the ground floor level, in short distances and remove the test keyboard
- turn the control panel's operation mode selector to the desired position in order to bring back the machine in normal functioning condition

### 11.4.1 Resetting the safety brake device

If the safety brake intervenes during normal operation, specifically trained personnel must inspect the motor brake, the transmission, the pinion, the rack, the guides, and the rollers. The cause must be identified and eliminated before the safety device is re-activated. The above-mentioned inspection may be omitted only if the safety brake device has been intervened as a result of a drop test.

To reset the safety brake's functionality, press the UP pushbutton on the DROP TEST PENDANT to move the machine upward for a short distance (1 mast section).

## ATTENTION:

For safety reasons, the safety brake must never be disassembled other than to reset it. For this reason, the safety brake is sealed.

**ATTENTION:**

The safety brake device must be checked every 5 years at BETA MAX.  
The review date is stamped on the plate of each parachute.

## 11.5 ELECTRICAL SYSTEM MAINTENANCE

All inspection and maintenance operations of the electrical system must always be carried out with the supply voltage disconnected.

A copy of the wiring diagram of the safety circuits must be kept near the electrical control panel.

### **DANGER:**

**Before accessing the internal part of the electrical control panel 15 minute after it has been disconnected, so that all circuits can dispel their residual energy.**

#### 11.5.1 Maintenance of the electrical system rectifier

For correct verification of the installed, live rectifier, use an instrument with a mobile coil and proceed as described below:

- measure the continuous voltage between the clamps (+) and (-) and the alternating voltage between the clamps marked with the appropriate symbol
- verify that the voltage value is between 35% and 45% of the alternating supply voltage value
- For correct verification of the installed but not connected rectifier, use an ohmmeter or a measuring instrument for direct current and proceed as described below
- check the rectifier diodes, verifying continuity between the marked clamps on the diode
- verify that the diodes do not allow the current to pass in one direction and when the probes of the measuring instrument are inverted, the current is allowed to pass in the opposite direction. Residual resistance, detected in the flowing direction of the current, is caused by the threshold voltage of the diodes
- verify the resistance value between the clamps (+) and (-) of the brake rectifier. There must be no connection when verifying the diode quality

### **NOTE:**

**In order to carry out such maintenance, refer to the wiring diagram that is placed near the electrical control panel.**

### **ATTENTION:**

**It is required that only specialized and authorized personnel or BETA MAX technical support carry out all inspection and repair operations on the installed rectifiers.**



## 11.6 TECHNICAL SUPPORT

Technical support for the machine is provided directly by the BETA MAX, Inc. by calling or sending a fax to the numbers below:

**Ph. 321-727-3737**  
**TF. 800-233-5112**  
**Fax 321-768-9517**

## CHAPTER 12: ADDITIONAL INSTRUCTIONS

Record of modifications

Revision	Executor	Date	Description of modification

## 12 ADDITIONAL INSTRUCTIONS

### 12.1 MACHINE NOISE LEVEL

The sound power level measured on an equipment representative of the type described in the manual:

Sound pressure	LPA	=	76.2 dB(A)
Sound power level	LWA	=	94.5 dB(A)
Uncertainty of measurement			1.50 dB(A)
Guaranteed sound power			96.0 dB(A)

### 12.2 INDICATIONS TO DECOMMISSION THE MACHINE

To decommission the machine, it must be disposed of accordingly; mechanical components that consist of steel and aluminum alloys are to be disposed of together and electrical and electronic components are to be disposed of at special facilities, in accordance with the relevant regulations that are in force in the user's country.

It is recommended to separate the materials to facilitate storage and/or recycling processes.



## CHAPTER 13: WARRANTY

Record of modifications

Revision	Executor	Date	Description of modification



## 13 WARRANTY

### 13.1 WARRANTY

Beta Max, Incorporated warrants all MAX CLIMBER RACK & PINION HOISTS to be free from defects in material and workmanship under normal use and service provided it has been maintained as specified in the owner’s manual.

Beta Max, Incorporated will provide to the original purchaser\*\* with a 12-month limited warranty on all parts excluding those parts whose warranty schedule is listed below. Our obligation under this warranty, as outlined below, is limited to repairing or replacing, at our discretion, any part of the unit, which proves upon examination to be defective in material or workmanship. The item is to be returned to Beta Max, Incorporated through an authorized distributor. The warranty period below is from the date that the equipment is sold to the original purchaser\*\*. All return shipments must be prepaid by the customer.

<u>Limited High Wear Items:</u>	<u>Warranty</u>
<ul style="list-style-type: none"> <li>- Lights and Service Outlets</li> <li>- Limit Switches</li> <li>- Landing and Car Door Rollers &amp; Cable</li> <li>- All Electrical Components</li> </ul>	<b>90 Days</b>
<u>Extended Warranty Items:</u>	<u>Warranty</u>
<ul style="list-style-type: none"> <li>- Motor and Motor Brake Assembly</li> <li>- Transmission/Gearbox</li> </ul>	<b>2 Years</b>
<ul style="list-style-type: none"> <li>- Base Frame</li> <li>- Mast</li> </ul>	<b>5 Years</b>
<ul style="list-style-type: none"> <li>- Emergency Brake (Safety Device) (Good for the extent of the brake certification period)</li> </ul>	<b>3-5 Years</b>

\*\* “Original Purchaser” definition:

for rental machines: Dealer,  
 for resale machines: First User.



Any parts proven to be defective upon our inspection will be repaired or replaced at no cost. The obligation under this warranty includes freight costs if determined the product failed under normal usage within the above-described time.

The manufacturer reserves the right to have the warranty serviced by the distributor from whom the unit was purchased. The distributor will make arrangements with the factory for repairs or replacement of parts within the terms of this warranty. Distributors must get a return authorization number from Beta Max before any item is returned for repairs or replacement.

Beta Max, Incorporated's obligation is limited to replacing parts and does not include replacing the complete unit. This warranty is void on any unit that has been modified or tampered with, repaired by persons other than a factory representative or an authorized Beta Max distributor, repaired with other than Beta Max standard parts, or damaged by reasons of accident, alteration, misuse or abuse.

This warranty is in lieu of all other warranties, expressed or implied. We do not authorize any person or representative to make any guarantee or to assume for us any liability in connection with the sale of our products other than those contained herein. Any agreement outside of or contradictory to the foregoing shall be void and of no effect.



**This page has been left blank for formatting purposes**



## Appendix A

Installation Data Sheet Form (Section 6.2)



**This page has been left blank for formatting purposes**



1895 Robert J. Conlan Blvd NE  
 Palm Bay, FL 32905  
 Ph. (800) 233-5112  
 Fax (321) 768-9517  
[www.betamaxhoist.com](http://www.betamaxhoist.com)

**Installation Data Sheet Form**  
**MC1600TP/M V**

**PROJECT NAME:** \_\_\_\_\_

**PROJECT ADDRESS:** \_\_\_\_\_

**SITE MANAGER:** \_\_\_\_\_

**Machine Installation Type:** TRANSPORT PLATFORM  MATERIAL HOIST

**Serial Number:** \_\_\_\_\_

**Unit Weight:** \_\_\_\_\_

**Max Height:** \_\_\_\_\_

**Max Load:** \_\_\_\_\_

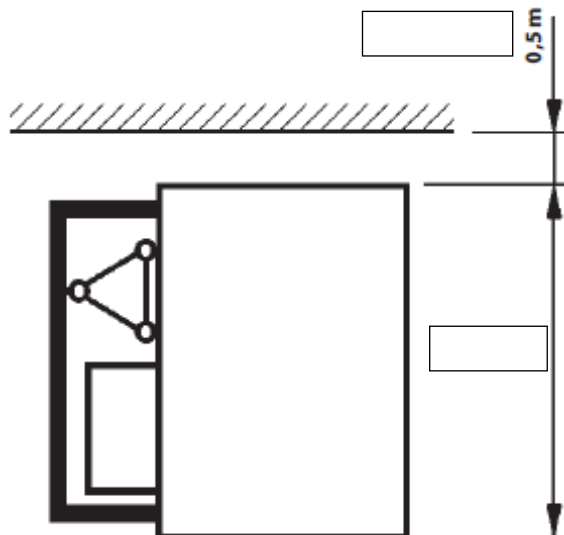

Machine Placement

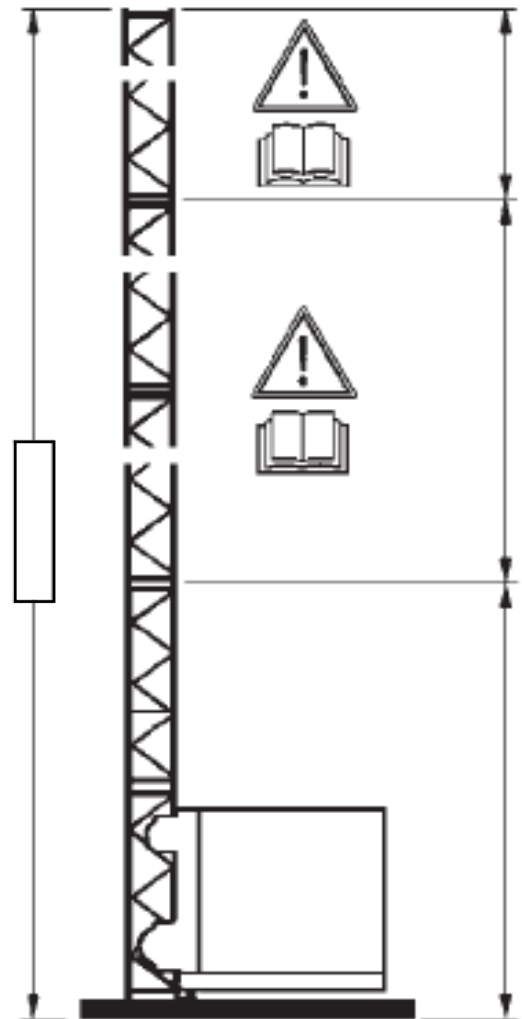

Anchorage Placement



**This page has been left blank for formatting purposes**



## Appendix B

Verification and Test Data Sheet Form (Section 6.4)



**This page has been left blank for formatting purposes**



1895 Robert J. Conlan Blvd NE  
 Palm Bay, FL 32905  
 Ph. (800) 233-5112  
 Fax (321) 768-9517  
[www.betamaxhoist.com](http://www.betamaxhoist.com)

**Verification and Test Data Sheet**  
**MC1600TP/M V**

**SECTION I – VERIFICATION OF DAMAGE DUE TO TRANSPORTATION**

**Note:** If any item is marked DAMAGED, write comments in the notes section.

	<b>OK</b>	<b>DAMAGED</b>	<b>N/A</b>
1. BASE UNIT.....	<input type="checkbox"/>	<input type="checkbox"/>	<input type="checkbox"/>
2. LIFTING UNIT.....	<input type="checkbox"/>	<input type="checkbox"/>	<input type="checkbox"/>
3. LOADING UNIT.....	<input type="checkbox"/>	<input type="checkbox"/>	<input type="checkbox"/>
4. ELECTRICAL CONTROL PANELS (BASE AND ONBOARD THE MACHINE).....	<input type="checkbox"/>	<input type="checkbox"/>	<input type="checkbox"/>
5. BASE ENCLOSURE AND ACCESS DOOR.....	<input type="checkbox"/>	<input type="checkbox"/>	<input type="checkbox"/>
6. CONTROL AND POWER ELECTRICAL CABLES.....	<input type="checkbox"/>	<input type="checkbox"/>	<input type="checkbox"/>
7. MAST.....	<input type="checkbox"/>	<input type="checkbox"/>	<input type="checkbox"/>
8. WALL ANCHORS.....	<input type="checkbox"/>	<input type="checkbox"/>	<input type="checkbox"/>
9. CABLE GUIDES AND DRUM.....	<input type="checkbox"/>	<input type="checkbox"/>	<input type="checkbox"/>
10. FLOOR-LEVEL SAFETY DEVICES (DOOR/GATES).....	<input type="checkbox"/>	<input type="checkbox"/>	<input type="checkbox"/>
11. FLOOR-LEVEL CALLING DEVICES (IF PRESENT).....	<input type="checkbox"/>	<input type="checkbox"/>	<input type="checkbox"/>

**SECTION II – VERIFICATION OF MACHINE MISSING COMPONENTS**

**Note:** If any item is marked MISSING, write comments in the notes section.

	<b>OK</b>	<b>MISSING</b>	<b>N/A</b>
1. MAST.....	<input type="checkbox"/>	<input type="checkbox"/>	<input type="checkbox"/>
2. WALL ANCHORS.....	<input type="checkbox"/>	<input type="checkbox"/>	<input type="checkbox"/>
3. CONTROL AND POWER ELECTRICAL CABLES.....	<input type="checkbox"/>	<input type="checkbox"/>	<input type="checkbox"/>
4. BRAKING DEVICES AND PADS.....	<input type="checkbox"/>	<input type="checkbox"/>	<input type="checkbox"/>
5. CABLE GUIDES AND DRUM.....	<input type="checkbox"/>	<input type="checkbox"/>	<input type="checkbox"/>
6. FLOOR-LEVEL SAFETY DEVICES (DOOR/GATES).....	<input type="checkbox"/>	<input type="checkbox"/>	<input type="checkbox"/>
7. FLOOR-LEVEL CALLING DEVICES (IF PRESENT).....	<input type="checkbox"/>	<input type="checkbox"/>	<input type="checkbox"/>

### SECTION III – VERIFICATION OF SAFETY EQUIPMENT

**Note:** If any item is marked FAIL, write comments in the notes section.

	PASS	FAIL	N/A
1. WEAR AND TEAR/USAGE OF THE MOTOR PINION.....	<input type="checkbox"/>	<input type="checkbox"/>	<input type="checkbox"/>
2. WEAR AND TEAR/USAGE OF THE GUIDE ROLLERS.....	<input type="checkbox"/>	<input type="checkbox"/>	<input type="checkbox"/>
3. WEAR AND TEAR/USAGE OF THE RACK TEETH ON THE MAST.....	<input type="checkbox"/>	<input type="checkbox"/>	<input type="checkbox"/>
4. WEAR AND TEAR/USAGE OF THE SAFETY DEVICE PINION.....	<input type="checkbox"/>	<input type="checkbox"/>	<input type="checkbox"/>
5. WEAR AND TEAR/USAGE OF THE ELECTRIC MOTOR BRAKE.....	<input type="checkbox"/>	<input type="checkbox"/>	<input type="checkbox"/>
6. SAFETY DEVICE EXPIRATION DATE.....	<input type="checkbox"/>	<input type="checkbox"/>	<input type="checkbox"/>
7. MECHANICAL INTERLOCKS OF THE ACCESS DOORS/RAMPS FOR THE LOADING UNIT AND THE DOOR/GATE.....	<input type="checkbox"/>	<input type="checkbox"/>	<input type="checkbox"/>
8. MECHANICAL INTERLOCKS OF THE ACCESS DOORS/GATES AND BASE ENCLOSURE FOR THE FLOOR-LEVELS.....	<input type="checkbox"/>	<input type="checkbox"/>	<input type="checkbox"/>
9. EMERGENCY PUSHBUTTONS.....	<input type="checkbox"/>	<input type="checkbox"/>	<input type="checkbox"/>
10. UPWARD AND DOWNWARD OVERTRAVEL LIMIT SWITCH.....	<input type="checkbox"/>	<input type="checkbox"/>	<input type="checkbox"/>
11. UPWARD AND DOWNWARD OVERTRAVEL PAD.....	<input type="checkbox"/>	<input type="checkbox"/>	<input type="checkbox"/>
12. UP AND DOWN END-OF-TRAVEL LIMIT SWITCH.....	<input type="checkbox"/>	<input type="checkbox"/>	<input type="checkbox"/>
13. UP AND DOWN END-OF-TRAVEL PAD.....	<input type="checkbox"/>	<input type="checkbox"/>	<input type="checkbox"/>
14. SAFETY DEVICE LIMIT SWITCH.....	<input type="checkbox"/>	<input type="checkbox"/>	<input type="checkbox"/>
15. ERECTION PLATFORM LIMIT SWITCH.....	<input type="checkbox"/>	<input type="checkbox"/>	<input type="checkbox"/>
16. LIMIT SWITCH FAR ACCESS DOORS FOR THE LOADING UNIT AND THE BASE ENCLOSURE DOOR.....	<input type="checkbox"/>	<input type="checkbox"/>	<input type="checkbox"/>

### SECTION IV – VERIFICATION OF MACHINE CONTROLS

**Note:** If any item is marked FAIL, write comments in the notes section.

	PASS	FAIL	N/A
1. FLOOR STOP LIMIT SWITCH.....	<input type="checkbox"/>	<input type="checkbox"/>	<input type="checkbox"/>
2. FLOOR STOP PAD.....	<input type="checkbox"/>	<input type="checkbox"/>	<input type="checkbox"/>
3. UP PUSHBUTTON.....	<input type="checkbox"/>	<input type="checkbox"/>	<input type="checkbox"/>
4. DOWN PUSHBUTTON.....	<input type="checkbox"/>	<input type="checkbox"/>	<input type="checkbox"/>
5. NEXT FLOOR PUSHBUTTON.....	<input type="checkbox"/>	<input type="checkbox"/>	<input type="checkbox"/>
6. OPERATION OF MANUAL LOWERING.....	<input type="checkbox"/>	<input type="checkbox"/>	<input type="checkbox"/>
7. LIMIT SWITCH FOR FLOOR-LEVEL SAFETY DEVICES (DOOR/GATES).....	<input type="checkbox"/>	<input type="checkbox"/>	<input type="checkbox"/>





**This page has been left blank for formatting purposes**



## Appendix C

General Maintenance (Daily) Checklist Form (Section 11.2.1)



**This page has been left blank for formatting purposes**



1895 Robert J. Conlan Blvd NE  
 Palm Bay, FL 32905  
 Ph. (800) 233-5112  
 Fax (321) 768-9517  
[www.betamaxhoist.com](http://www.betamaxhoist.com)

**Operator's Daily Checklist**  
**MC1600TP/M V**

**OPERATOR:** \_\_\_\_\_ **DATE:** \_\_\_\_\_

**SERIAL NUMBER:** \_\_\_\_\_ **TIME:** \_\_\_\_\_

**Note:** If any item is marked FAIL, write comments in the notes section.

	PASS	FAIL	N/A
1. CHECK FOR FALLEN HARDWARE IN PIT/SURROUNDING AREA (e.g., MAST BOLTS, CABLE GUIDES, CONSTRUCTION MATERIAL).....	<input type="checkbox"/>	<input type="checkbox"/>	<input type="checkbox"/>
2. CHECK HOISTWAY FOR OBSTRUCTIONS.....	<input type="checkbox"/>	<input type="checkbox"/>	<input type="checkbox"/>
3. ENSURE THAT ICE IS NOT PRESENT ON THE MAST OF TRAILING CABLE (MUST BE REMOVED BEFORE OPERATION).....	<input type="checkbox"/>	<input type="checkbox"/>	<input type="checkbox"/>
4. IN CASE OF INTENSE WEATHER CONDITIONS PRIOR TO OPERATION, ALL ESSENTIAL PARTS OF MACHINE MUST BE INSPECTED.....	<input type="checkbox"/>	<input type="checkbox"/>	<input type="checkbox"/>
5. ENSURE WIND SPEEDS DO NOT EXCEED SAFE OPERATING CONDITIONS.....	<input type="checkbox"/>	<input type="checkbox"/>	<input type="checkbox"/>
6. CHECK GREASE LEVEL IN AUTOMATIC GREASER.....	<input type="checkbox"/>	<input type="checkbox"/>	<input type="checkbox"/>
7. CHECK FOR ANY SIGNS OF OIL LEAKS AROUND GEARBOX AND MOTOR....	<input type="checkbox"/>	<input type="checkbox"/>	<input type="checkbox"/>
8. CHECK THE BASE AND LOADING UNIT FOR DAMAGE.....	<input type="checkbox"/>	<input type="checkbox"/>	<input type="checkbox"/>
9. CHECK THAT ALL HOIST GUARDS ARE IN PLACE (e.g., MAST GUARD, WALL PANELS).....	<input type="checkbox"/>	<input type="checkbox"/>	<input type="checkbox"/>
10. CHECK EMERGENCY STOP PUSHBUTTONS AND MAIN SWITCHES.....	<input type="checkbox"/>	<input type="checkbox"/>	<input type="checkbox"/>
11. PERFORM TRIAL RUNS WITH THE EMERGENCY STOP PUSHBUTTONS ENGAGED TO VERIFY FUNCTIONALITY.....	<input type="checkbox"/>	<input type="checkbox"/>	<input type="checkbox"/>
12. PERFORM TRIAL RUNS WITH CAR DOOR/RAMP OPEN TO VERIFY THAT UNIT DOES NOT RUN.....	<input type="checkbox"/>	<input type="checkbox"/>	<input type="checkbox"/>
13. CHECK THE CONTROLS ARE FUNCTIONING AND ARE UNDAMAGED.....	<input type="checkbox"/>	<input type="checkbox"/>	<input type="checkbox"/>
14. PERFORM A TRIAL RUN TO VERIFY MOTOR AND MOTOR BRAKE ARE FUNCTIONING.....	<input type="checkbox"/>	<input type="checkbox"/>	<input type="checkbox"/>
15. PERFORM A TRIAL RUN TO VERIFY THE TRAVEL DOWN STOP IS FUNCTIONING.....	<input type="checkbox"/>	<input type="checkbox"/>	<input type="checkbox"/>
16. CHECK MAST SECTIONS FOR MISSING OR LOOSE HARDWARE.....	<input type="checkbox"/>	<input type="checkbox"/>	<input type="checkbox"/>
17. CHECK WALL ANCHORS FOR MISSING OR LOOSE HARDWARE.....	<input type="checkbox"/>	<input type="checkbox"/>	<input type="checkbox"/>
18. CHECK CABLE GUIDES FOR MISSING OR LOOSE HARDWARE.....	<input type="checkbox"/>	<input type="checkbox"/>	<input type="checkbox"/>
19. CHECK CABLE GUIDES FOR MISSING CABLE KEEPERS.....	<input type="checkbox"/>	<input type="checkbox"/>	<input type="checkbox"/>
20. CHECK THE TRAILING CABLE ENSURING ALL OF THE CABLE IS SPOOLED INTO THE CABLE DRUM.....	<input type="checkbox"/>	<input type="checkbox"/>	<input type="checkbox"/>





## Appendix D

General Maintenance (40 hours) Checklist Form (Section 11.2.2)



**This page has been left blank for formatting purposes**



1895 Robert J. Conlan Blvd NE  
 Palm Bay, FL 32905  
 Ph. (800) 233-5112  
 Fax (321) 768-9517  
[www.betamaxhoist.com](http://www.betamaxhoist.com)

## General Maintenance

40 Hours

MC1600TP/M V

**Note:** If any item is marked FAIL, write comments in the notes section.

	PASS	FAIL	N/A
1. CHECK FOR FALLEN HARDWARE IN PIT/SURROUNDING AREA (e.g., MAST BOLTS, CABLE GUIDES, CONSTRUCTION MATERIAL).....	<input type="checkbox"/>	<input type="checkbox"/>	<input type="checkbox"/>
2. CHECK HOISTWAY FOR OBSTRUCTIONS.....	<input type="checkbox"/>	<input type="checkbox"/>	<input type="checkbox"/>
3. ENSURE THAT ICE IS NOT PRESENT ON THE MAST OF TRAILING CABLE (MUST BE REMOVED BEFORE OPERATION).....	<input type="checkbox"/>	<input type="checkbox"/>	<input type="checkbox"/>
4. ENSURE WIND SPEEDS DO NOT EXCEED SAFE OPERATING CONDITIONS.....	<input type="checkbox"/>	<input type="checkbox"/>	<input type="checkbox"/>
5. CHECK SUPPORT CONDITIONS OF THE BASE FRAME.....	<input type="checkbox"/>	<input type="checkbox"/>	<input type="checkbox"/>
6. ENSURE THAT ALL WARNING SIGNS ARE LEGIBLE AND IN THE RIGHT PLACE.....	<input type="checkbox"/>	<input type="checkbox"/>	<input type="checkbox"/>
7. ENSURE THAT ALL DOCUMENTS ARE READILY AVAILABLE AND LEGIBLE...	<input type="checkbox"/>	<input type="checkbox"/>	<input type="checkbox"/>
8. CHECK THE OIL LEVEL OF THE GEARBOX.....	<input type="checkbox"/>	<input type="checkbox"/>	<input type="checkbox"/>
9. LUBRICATE THE PINION SHAFT OF THE SAFETY DEVICE THROUGH THE PROPER GREASE NIPPLE.....	<input type="checkbox"/>	<input type="checkbox"/>	<input type="checkbox"/>
10. LUBRICATE THE INDICATED PARTS PAYING PARTICULAR ATTENTION TO THE RACK.....	<input type="checkbox"/>	<input type="checkbox"/>	<input type="checkbox"/>
11. CHECK THE GREASE LEVEL OF THE AUTOMATIC GREASER.....	<input type="checkbox"/>	<input type="checkbox"/>	<input type="checkbox"/>
12. ENSURE ALL CONNECTIONS OF THE GUIDE ROLLERS TO THE MACHINE'S FRAME ARE CORRECT AND TIGHT.....	<input type="checkbox"/>	<input type="checkbox"/>	<input type="checkbox"/>
13. CHECK THE RACK OF THE MAST AND THE MOTOR PINION; ENSURE THERE IS NO DAMAGE, ALIGNMENT ERRORS, OR DEFECTIVE CONNECTIONS.....	<input type="checkbox"/>	<input type="checkbox"/>	<input type="checkbox"/>
14. ENSURE THAT THE ELECTRIC MOTOR BRAKE FUNCTIONS PROPERLY, THE LOADING UNIT MUST STOP WITHIN THE SET LIMITS WHEN THE BRAKE IS APPLIED.....	<input type="checkbox"/>	<input type="checkbox"/>	<input type="checkbox"/>
15. INSPECT ALL BOLTED JOINTS BETWEEN THE COMPONENTS OF THE MAST.	<input type="checkbox"/>	<input type="checkbox"/>	<input type="checkbox"/>
16. INSPECT ALL BOLTED JOINTS OF THE WALL ANCHORS.....	<input type="checkbox"/>	<input type="checkbox"/>	<input type="checkbox"/>
17. INSPECT THE CABLE GUIDES AND CHECK FOR MISSING CABLE KEEPERS.	<input type="checkbox"/>	<input type="checkbox"/>	<input type="checkbox"/>
18. CHECK EMERGENCY STOP PUSHBUTTONS AND MAIN SWITCHES.....	<input type="checkbox"/>	<input type="checkbox"/>	<input type="checkbox"/>
19. CHECK THAT THE CONTROLS ARE FUNCTIONING AND ARE UNDAMAGED..	<input type="checkbox"/>	<input type="checkbox"/>	<input type="checkbox"/>
20. PERFORM A TRIAL RUN WITH THE EMERGENCY STOP PUSHBUTTONS ENGAGED TO VERIFY FUNCTIONALITY.....	<input type="checkbox"/>	<input type="checkbox"/>	<input type="checkbox"/>





## Appendix E

General Maintenance (125 hours) Checklist Form (Section 11.2.3)



**This page has been left blank for formatting purposes**



1895 Robert J. Conlan Blvd NE  
 Palm Bay, FL 32905  
 Ph. (800) 233-5112  
 Fax (321) 768-9517  
[www.betamaxhoist.com](http://www.betamaxhoist.com)

## General Maintenance

125 Hours

MC1600TP/M V

**Note:** If any item is marked FAIL, write comments in the notes section.

	PASS	FAIL	N/A
1. CHECK FOR FALLEN HARDWARE IN PIT/SURROUNDING AREA (e.g., MAST BOLTS, CABLE GUIDES, CONSTRUCTION MATERIAL).....	<input type="checkbox"/>	<input type="checkbox"/>	<input type="checkbox"/>
2. CHECK HOISTWAY FOR OBSTRUCTIONS.....	<input type="checkbox"/>	<input type="checkbox"/>	<input type="checkbox"/>
3. ENSURE THAT ICE IS NOT PRESENT ON THE MAST OF TRAILING CABLE (MUST BE REMOVED BEFORE OPERATION).....	<input type="checkbox"/>	<input type="checkbox"/>	<input type="checkbox"/>
4. ENSURE WIND SPEEDS DO NOT EXCEED SAFE OPERATING CONDITIONS.....	<input type="checkbox"/>	<input type="checkbox"/>	<input type="checkbox"/>
5. CHECK SUPPORT CONDITIONS OF THE BASE FRAME.....	<input type="checkbox"/>	<input type="checkbox"/>	<input type="checkbox"/>
6. ENSURE THAT ALL WARNING SIGNS ARE LEGIBLE AND IN THE RIGHT PLACE.....	<input type="checkbox"/>	<input type="checkbox"/>	<input type="checkbox"/>
7. ENSURE THAT ALL DOCUMENTS ARE READILY AVAILABLE AND LEGIBLE...	<input type="checkbox"/>	<input type="checkbox"/>	<input type="checkbox"/>
8. CHECK THE OIL LEVEL OF THE GEARBOX.....	<input type="checkbox"/>	<input type="checkbox"/>	<input type="checkbox"/>
9. LUBRICATE THE PINION SHAFT OF THE SAFETY DEVICE THROUGH THE PROPER GREASE NIPPLE.....	<input type="checkbox"/>	<input type="checkbox"/>	<input type="checkbox"/>
10. LUBRICATE THE INDICATED PARTS, PAYING PARTICULAR ATTENTION TO THE RACK.....	<input type="checkbox"/>	<input type="checkbox"/>	<input type="checkbox"/>
11. CHECK THE GREASE LEVEL OF THE AUTOMATIC GREASER.....	<input type="checkbox"/>	<input type="checkbox"/>	<input type="checkbox"/>
12. ENSURE ALL CONNECTIONS OF THE GUIDE ROLLERS TO THE MACHINE'S FRAME ARE CORRECT AND TIGHT.....	<input type="checkbox"/>	<input type="checkbox"/>	<input type="checkbox"/>
13. CHECK THE RACK OF THE MAST AND THE MOTOR PINION; ENSURE THERE IS NO DAMAGE, ALIGNMENT ERRORS, OR DEFECTIVE CONNECTIONS.....	<input type="checkbox"/>	<input type="checkbox"/>	<input type="checkbox"/>
14. ENSURE THAT THE ELECTRIC MOTOR BRAKE FUNCTIONS PROPERLY, THE LOADING UNIT MUST STOP WITHIN THE SET LIMITS WHEN THE BRAKE IS APPLIED.....	<input type="checkbox"/>	<input type="checkbox"/>	<input type="checkbox"/>
15. INSPECT ALL BOLTED JOINTS BETWEEN THE COMPONENTS OF THE MAST.	<input type="checkbox"/>	<input type="checkbox"/>	<input type="checkbox"/>
16. INSPECT ALL BOLTED JOINTS OF THE WALL ANCHORS.....	<input type="checkbox"/>	<input type="checkbox"/>	<input type="checkbox"/>
17. INSPECT THE CABLE GUIDES AND CHECK FOR MISSING CABLE KEEPERS.	<input type="checkbox"/>	<input type="checkbox"/>	<input type="checkbox"/>
18. CHECK EMERGENCY STOP PUSHBUTTONS AND MAIN SWITCHES.....	<input type="checkbox"/>	<input type="checkbox"/>	<input type="checkbox"/>
19. CHECK THE CONTROLS ARE FUNCTIONING AND ARE UNDAMAGED.....	<input type="checkbox"/>	<input type="checkbox"/>	<input type="checkbox"/>
20. PERFORM A TRIAL RUN WITH THE EMERGENCY STOP PUSHBUTTONS ENGAGED TO VERIFY FUNCTIONALITY.....	<input type="checkbox"/>	<input type="checkbox"/>	<input type="checkbox"/>





## Appendix F

General Maintenance (500 hours) Checklist Form (Section 11.2.4)



**This page has been left blank for formatting purposes**



1895 Robert J. Conlan Blvd NE  
 Palm Bay, FL 32905  
 Ph. (800) 233-5112  
 Fax (321) 768-9517  
[www.betamaxhoist.com](http://www.betamaxhoist.com)

## General Maintenance

500 Hours

MC1600TP/M V

**Note:** If any item is marked FAIL, write comments in the notes section.

	PASS	FAIL	N/A
1. CHECK FOR FALLEN HARDWARE IN PIT/SURROUNDING AREA (e.g., MAST BOLTS, CABLE GUIDES, CONSTRUCTION MATERIAL).....	<input type="checkbox"/>	<input type="checkbox"/>	<input type="checkbox"/>
2. CHECK HOISTWAY FOR OBSTRUCTIONS.....	<input type="checkbox"/>	<input type="checkbox"/>	<input type="checkbox"/>
3. ENSURE THAT ICE IS NOT PRESENT ON THE MAST OF TRAILING CABLE (MUST BE REMOVED BEFORE OPERATION).....	<input type="checkbox"/>	<input type="checkbox"/>	<input type="checkbox"/>
4. ENSURE WIND SPEEDS DO NOT EXCEED SAFE OPERATING CONDITIONS.....	<input type="checkbox"/>	<input type="checkbox"/>	<input type="checkbox"/>
5. CHECK SUPPORT CONDITIONS OF THE BASE FRAME.....	<input type="checkbox"/>	<input type="checkbox"/>	<input type="checkbox"/>
6. CHECK THE STATE OF PRESERVATION OF THE BASE FRAME.....	<input type="checkbox"/>	<input type="checkbox"/>	<input type="checkbox"/>
7. CHECK THE STATE OF PRESERVATION OF THE LOADING UNIT AND DOORS/RAMPS.....	<input type="checkbox"/>	<input type="checkbox"/>	<input type="checkbox"/>
8. CHECK THE STATE OF PRESERVATION OF THE LIFTING UNIT.....	<input type="checkbox"/>	<input type="checkbox"/>	<input type="checkbox"/>
9. CHECK THE STATE OF PRESERVATION OF THE ELECTRICAL PANELS.....	<input type="checkbox"/>	<input type="checkbox"/>	<input type="checkbox"/>
10. ENSURE THAT ALL WARNING SIGNS ARE LEGIBLE AND IN THE RIGHT PLACE.....	<input type="checkbox"/>	<input type="checkbox"/>	<input type="checkbox"/>
11. ENSURE THAT ALL DOCUMENTS ARE READILY AVAILABLE AND LEGIBLE..	<input type="checkbox"/>	<input type="checkbox"/>	<input type="checkbox"/>
12. CHECK THE OIL LEVEL OF THE GEARBOX.....	<input type="checkbox"/>	<input type="checkbox"/>	<input type="checkbox"/>
13. LUBRICATE THE PINION SHAFT OF THE SAFETY DEVICE THROUGH THE PROPER GREASE NIPPLE.....	<input type="checkbox"/>	<input type="checkbox"/>	<input type="checkbox"/>
14. LUBRICATE THE INDICATED PARTS, PAYING PARTICULAR ATTENTION TO THE RACK.....	<input type="checkbox"/>	<input type="checkbox"/>	<input type="checkbox"/>
15. CHECK THE GREASE LEVEL OF THE AUTOMATIC GREASER.....	<input type="checkbox"/>	<input type="checkbox"/>	<input type="checkbox"/>
16. ENSURE ALL CONNECTIONS OF THE GUIDE ROLLERS TO THE MACHINE'S FRAME ARE CORRECT AND TIGHT.....	<input type="checkbox"/>	<input type="checkbox"/>	<input type="checkbox"/>
17. CHECK THE RACK OF THE MAST AND THE MOTOR PINION; ENSURE THERE IS NO DAMAGE, ALIGNMENT ERRORS, OR DEFECTIVE CONNECTIONS.....	<input type="checkbox"/>	<input type="checkbox"/>	<input type="checkbox"/>
18. ENSURE THAT THE ELECTRIC MOTOR BRAKE FUNCTIONS PROPERLY, THE LOADING UNIT MUST STOP WITHIN THE SET LIMITS WHEN THE BRAKE IS APPLIED.....	<input type="checkbox"/>	<input type="checkbox"/>	<input type="checkbox"/>
19. TIGHTEN ALL BOLTED JOINTS BETWEEN THE COMPONENTS OF THE MAST.	<input type="checkbox"/>	<input type="checkbox"/>	<input type="checkbox"/>
20. TIGHTEN ALL BOLTED JOINTS OF THE WALL ANCHORS.....	<input type="checkbox"/>	<input type="checkbox"/>	<input type="checkbox"/>



**COMPANY:** \_\_\_\_\_

**JOBSITE ADDRESS:**

\_\_\_\_\_

**SERIAL NUMBER:** \_\_\_\_\_

\_\_\_\_\_

**YEAR OF MANUFACTURE:** \_\_\_\_\_

\_\_\_\_\_

**TECHNICIAN NAME:** \_\_\_\_\_ **DATE:** \_\_\_\_\_

**TECHNICIAN SIGNATURE:** \_\_\_\_\_

**This page has been left blank for formatting purpose**