



Original Instructions

TRANSPORT PLATFORM
MATERIAL HOIST

BETA MAX
MC2000PMB V

BY:



USE AND MAINTENANCE
INSTRUCTION MANUAL

Rev. 2.4 - 2025

SERIAL NUMBER: _ _ _ _ _

1895 Robert J. Conlan Blvd. NE
Palm Bay, FL 32905
PH: 800.233.5112 --- Fax 321.768.9517
www.betamaxhoist.com



BEFORE OPERATING, INSTALLING, OR CARRYING OUT MAINTENANCE ON THE UNIT IT IS IMPORTANT TO READ AND UNDERSTAND THE INFORMATION IN THIS MANUAL.

ATTENTION:

The machine must not be used when the instruction manual is missing or not readily available for consultation. A copy of this manual must always be at hand and available to the operators. Improper use of the machine may cause great danger to people or damage other people's property.

This manual is to be used only if the serial or model shown in the manual corresponds with the identification information shown on the machine. If they do not correspond, contact your BETA MAX retailer or agent.



Owner: _____

Company name: _____

Address: _____

USE AND MAINTENANCE INSTRUCTION MANUAL

Brand - Manufacturer: BETA MAX
Type: MAX CLIMBER
Model: MC2000PMB V

		<u>Date</u>	<u>Signature</u>
Written By:	Beta Max, Inc.	04-15-25	
Approval By:	Beta Max, Inc.		

Descriptions and photos are only to be considered as pure illustrations. They may or may not be exact representation due to updated and revised changes made to the product.

According to continuous technological innovations, Beta Max, Inc. reserves the right to make any modifications with the intention of improving the product without notice.

All rights reserved.

Copyright © 2025 BETA MAX, Inc.
Reproduction of this document by any means, in whole or in part, is prohibited without the authorization of BETA MAX, Inc.

TABLE OF CONTENTS

TABLE OF CONTENTS	I
1 INTRODUCTION	1-1
1.1 USE AND MAINTENANCE INSTRUCTION MANUAL	1-1
1.1.1 The importance of the manual	1-1
1.1.2 Conserving the manual	1-1
1.1.3 Consulting the manual	1-1
1.2 PURPOSE OF THE USE AND MAINTENANCE INSTRUCTION MANUAL	1-2
1.3 UPDATES OF THE MANUAL	1-4
1.4 DEFINITIONS	1-4
1.5 PREREQUISITES FOR THE MACHINE USER	1-5
1.5.1 Use and maintenance training	1-5
1.5.2 The user’s responsibility	1-5
1.5.3 Training on the particular model of machine	1-5
1.6 PREREQUISITES FOR THE ASSIGNED OPERATOR	1-6
1.6.1 Preparatory information	1-6
1.6.2 The operator’s training	1-6
2 GENERAL INFORMATION	2-1
2.1 IDENTIFICATION DATA OF THE MANUFACTURER AND THE MACHINE	2-1
2.2 MACHINE IDENTIFICATION PLATE	2-1
2.3 IDENTIFICATION SIGN	2-2
3 MACHINE INFORMATION	3-1
3.1 PREFACE	3-1
3.2 GENERAL DESCRIPTION	3-1
3.3 MACHINE LAYOUT	3-2
3.4 DESCRIPTION OF THE MACHINE	3-4
3.4.1 Base unit	3-6
3.4.2 Base enclosure	3-7
3.4.3 Vertical mast unit	3-8

3.4.4	Loading unit -----	3-9
3.4.5	Lifting unit-----	3-10
3.4.6	Floor landing unit -----	3-11
3.4.7	Electric cable guide unit -----	3-12
3.4.8	Electrical equipment-----	3-13
3.4.9	Electrical settings -----	3-13
3.4.9.1	Base control panel-----	3-14
3.4.9.2	Onboard control panel-----	3-15
3.4.9.3	VFD enclosure panel-----	3-16
3.4.9.4	Control keyboard-----	3-17
3.4.10	Centrifugal safety brake unit -----	3-18
3.4.11	Drop test pendant-----	3-19
3.4.12	Wall anchor unit -----	3-20
3.4.13	Platform for anchors mounting unit (erection platform) -----	3-21
3.4.14	Accessories -----	3-22
3.5	TECHNICAL SPECIFICATIONS OF THE MACHINE-----	3-24
3.5.1	General Data-----	3-24
3.5.2	Electrical specifications of the machine -----	3-24
3.5.3	Electrical -----	3-24
3.5.4	Manufacturing characteristics of the electric motor -----	3-24
3.5.5	Technical specifications of electric motor -----	3-24
3.5.6	Dimensions and capacities -----	3-25
3.5.7	Dimensions and weights -----	3-25
3.5.8	Loads/load capacity -----	3-25
3.5.9	Safety equipment -----	3-26
3.5.10	Recommended tightening torques -----	3-26
3.6	INTENDED USE -----	3-27
3.7	NORMAL CONDITIONS OF STORAGE-----	3-27
3.8	STORAGE CONDITIONS WITH TEMPERATURES REACHING A MINIMUM OF -4 -----	3-27
3.9	STORAGE CONDITIONS WITH TEMPERATURES LOWER THAN -4-----	3-28
3.10	AMBIENT WORKING CONDITIONS -----	3-28
4	WALL ANCHORS-----	4-1

4.1	PREAMBLE -----	4-1
4.1.1	Disposition of the machine -----	4-3
4.2	WALL ANCHORS -----	4-4
4.2.1	Distance between the anchors -----	4-5
4.2.2	The structure used for anchoring the machine -----	4-5
4.2.3	Allowed height of the topmost part above the last anchor -----	4-5
4.2.4	Mounting conditions for a free-standing mast -----	4-7
4.2.5	Condition for anchoring the mast for standard loading unit -----	4-8
4.2.6	Forces onto the wall anchor system -----	4-9
4.2.7	Type of anchor system -----	4-12
4.2.8	Working conditions with a free-standing mast (not anchored) -----	4-13
4.2.9	Information for the commissioning of the mast -----	4-13
4.3	INSTALLATION OF WALL-TIE ON THE MAST -----	4-15
5	HANDLING AND TRANSPORTATION -----	5-1
5.1	INTRODUCTION AND PRELIMINARY OPERATIONS -----	5-1
5.2	TRANSPORTATION -----	5-2
5.3	HANDLING -----	5-3
5.3.1	Fork Trucks -----	5-5
5.3.2	Lifting eye -----	5-6
5.4	LOADING AND UNLOADING -----	5-9
6	INSTALLATION -----	6-1
6.1	INTRODUCTION -----	6-1
6.2	INSTALLATION DATA SHEET -----	6-2
6.3	INSTALLATION PROCEDURE -----	6-3
6.3.1	Machine configuration -----	6-3
6.3.2	Machine configured in the STANDARD configuration -----	6-4
6.3.3	Converting the machine to the REVERSE configuration -----	6-5
6.3.3.1	Relocating the cable gooseneck -----	6-6
6.3.3.2	Relocating the trailing cable drum -----	6-7
6.4	TEST AND VERIFICATION DATA SHEET OF THE MACHINE'S COMPONENTS -----	6-8
6.5	FOUNDATION FOR POSITIONING THE MACHINE -----	6-9

6.5.1	Concrete slab resting on the ground -----	6-11
6.5.2	Concrete slab at the same level of the ground -----	6-11
6.5.3	Concrete slab below ground level -----	6-11
6.5.4	Minimum area for machine placement-----	6-11
6.6	DISTANCE OF THE MACHINE FROM OBSTACLES -----	6-13
6.7	MOUNTING INSTRUCTIONS -----	6-13
6.8	MOUNTING THE PRE-ASSEMBLED MACHINE -----	6-14
6.8.1	Positioning the machine on the ground-----	6-15
6.8.2	Adjustment of base leveling jacks -----	6-18
6.8.3	Preparing the machine’s functionality before connecting the power supply -----	6-19
6.8.4	Connecting the power supply -----	6-21
6.8.5	The first handling process of the machine -----	6-21
6.8.6	Machine parameters -----	6-25
6.9	MOUNTING THE MAST AND THE FIRST WALL ANCHOR -----	6-31
6.10	MOUNTING THE ANCHORS-----	6-37
6.11	MOUNTING THE ELECTRIC CABLE GUIDE -----	6-41
6.12	MOUNTING SUBSEQUENT MASTS-----	6-42
6.13	MOUNTING OF LANDING AND SLOWDOWN PADS -----	6-43
6.13.1	Landing pads -----	6-43
6.13.2	Floor level braking pads (floor stop)-----	6-44
6.13.2.1	Floor level programming -----	6-44
6.13.3	Procedure check -----	6-49
6.13.4	Procedure Verification -----	6-50
6.13.5	Examples of floor level programming -----	6-52
6.13.5.1	Example: recording of 2 floor levels -----	6-52
6.13.5.2	Example: addition of a floor between 2 existing floors -----	6-53
6.13.5.3	Example: removal of a single floor level-----	6-53
6.13.6	Wireless call station programing -----	6-54
6.13.6.1	System components -----	6-54
6.13.6.2	Example of component installation -----	6-57
6.13.6.3	Receiver configuration menu structure -----	6-58
6.14	MOUNTING THE DOORS-----	6-66

6.14.1	Mounting the sliding doors-----	6-66
6.15	GROUND ENCLOSURE ASSEMBLY -----	6-69
6.15.1	Ground enclosure extension for 700mm drum-----	6-69
7	COMMAND AND CONTROL DEVICES-----	7-1
7.1	GENERAL INFORMATION ON COMMAND DEVICES -----	7-1
7.2	COMMANDS ON THE BASE CONTROL PANEL -----	7-2
7.2.1	Main switch-----	7-3
7.2.2	FLOOR SELECTOR pushbutton-----	7-3
7.2.3	DOWN TO GROUND pushbutton -----	7-3
7.2.4	UP pushbutton-----	7-3
7.2.5	DOWN pushbutton -----	7-3
7.2.6	STOP NEXT FLOOR pushbutton -----	7-3
7.2.7	EMERGENCY pushbutton-----	7-3
7.2.8	Plug for TRAILING CABLE -----	7-3
7.2.9	Plug for AUXILLARY SAFETY SWITCH -----	7-4
7.2.10	Plug for GROUND GATE -----	7-4
7.2.11	Plug for FLOOR CALL BOXES-----	7-4
7.3	COMMANDS ON THE ONBOARD CONTROL PANEL -----	7-5
7.3.1	Main switch-----	7-6
7.3.2	Machine mode key switch (ERECTION / PROGRAMMING / NORMAL)-----	7-6
7.3.3	Plug for AUXILARY POWER-----	7-6
7.3.4	SIREN / ALARM pushbutton -----	7-6
7.3.5	DISPLAY screen-----	7-6
7.3.6	INCREASE FLOOR pushbutton-----	7-6
7.3.7	DECREASE FLOOR pushbutton -----	7-7
7.3.8	RUN / OPERATOR pushbutton -----	7-7
7.3.9	STOP NEXT FLOOR pushbutton-----	7-7
7.3.10	SEND TO GROUND pushbutton-----	7-7
7.3.11	Control mode key switch (CABIN ONLY / CABIN & GROUND) -----	7-7
7.3.12	ALARM / ERROR RESET pushbutton-----	7-7
7.3.13	AUTOMATIC GREASER key switch (OFF/ON) -----	7-7

7.3.14	CABIN LIGHT key switch (OFF/ON) -----	7-8
7.3.15	Signal light POWER-----	7-8
7.3.16	EMERGENCY pushbutton-----	7-8
7.3.17	OVERWEIGHT SENSOR controller-----	7-8
7.3.18	Plug for DROP TEST PENDANT -----	7-8
7.3.19	Plug for TRAILING CABLE -----	7-8
7.4	DISPLAY SCREEN CONTROLS -----	7-9
7.4.1	Display when operating from inside the cabin -----	7-9
7.4.2	Display when operating from Ground controls-----	7-9
7.4.3	Setting the floor of destination -----	7-10
7.4.4	Move the machine to selected destination-----	7-10
7.5	COMMANDS FOR FLOOR CALL BOXES -----	7-11
7.5.1	UP pushbutton-----	7-11
7.5.2	DOWN pushbutton -----	7-11
7.5.3	STOP NEXT FLOOR pushbutton-----	7-11
7.5.4	EMERGENCY pushbutton-----	7-11
7.5.5	Plug for FLOOR CALL BOXES-----	7-11
7.6	COMMANDS FOR WIRELESS CALL STATION -----	7-12
7.6.1	Up button -----	7-12
7.6.2	Down button-----	7-12
7.7	COMMANDS ON THE DROP TEST PENDANT-----	7-13
7.7.1	UP pushbutton-----	7-13
7.7.2	TEST pushbutton -----	7-13
7.7.3	EMERGENCY pushbutton-----	7-14
8	SAFETY REGULATIONS-----	8-1
8.1	DESCRIPTION OF THE MACHINE'S SAFETY SYSTEMS-----	8-1
8.2	MOVABLE GUARDS -----	8-2
8.2.1	Electrically controlled and mechanical interlocking movable guards -----	8-2
8.2.2	Electrically controlled movable guards-----	8-3
8.2.3	Movable guards which lock with a key or tool-----	8-4
8.3	FIXED GUARDS-----	8-5

8.4	SAFETY EQUIPMENT -----	8-6
8.4.1	Mechanical equipment-----	8-6
8.4.2	Electro-mechanical equipment -----	8-6
8.4.3	Electrical equipment-----	8-7
8.4.4	Overweight control device -----	8-9
8.5	LIST OF PLATES FOUND ON THE MACHINE -----	8-10
8.5.1	Signs onboard the machine -----	8-11
8.6	FUNDAMENTAL SAFETY REGULATIONS-----	8-13
8.6.1	General safety regulations-----	8-13
8.6.2	Local safety regulations -----	8-13
8.6.3	Environmental conditions -----	8-13
8.6.4	Pre-installation requirements-----	8-14
8.6.5	Individual protection gear regulations-----	8-14
8.6.6	Regulations pertaining to electricity -----	8-14
8.6.7	Regulations pertaining to spare parts-----	8-14
8.7	REGULATIONS PERTAINING TO MAXIMUM LOADS -----	8-15
8.8	RESIDUAL RISKS-----	8-16
8.8.1	Risks arising from operating with configurations not provided for by the manufacturer-----	8-16
8.8.2	Risks arising from an incorrect positioning of the machine -----	8-17
8.8.3	Shearing risk deriving from the machine proximity to obstacles-----	8-17
8.8.4	Risks arising from transporting the machine -----	8-18
8.8.5	Risks arising from incorrect assembly on the ground -----	8-19
8.8.6	Risks arising from incorrect overground assembly -----	8-20
8.8.7	Risks arising from functional verification of the machine-----	8-21
8.8.8	Risks arising from the machine’s normal operation-----	8-22
8.8.9	Risks arising from descending the machine manually -----	8-23
8.8.10	Risks arising from handling the machine at the construction site -----	8-24
8.8.11	Risks arising from disassembling the machine -----	8-24
9	PREPARATION FOR MACHINE USE-----	9-1
9.1	SAFETY REQUIREMENTS BEFORE HANDLING THE MACHINE-----	9-1
9.2	SAFETY REQUIREMENTS DURING MACHINE OPERATION-----	9-2

9.3	SAFETY VERIFICATION INSTRUCTIONS -----	9-2
9.3.1	General verification of the machine -----	9-2
9.3.2	Electrical verification of the machine -----	9-3
9.3.3	Verification of the machine’s motion -----	9-3
9.3.4	Daily verification prior to operating the machine-----	9-4
9.4	MANUAL DESCENT PROCEDURE -----	9-5
9.4.1	General regulations to descend manually but safely-----	9-8
9.5	OPERATING THE MACHINE -----	9-9
9.6	OPENING OF GATES FOR EGRESS TO BUILDING-----	9-10
9.7	SHUTTING DOWN THE MACHINE AT THE END OF A WORK SHIFT -----	9-11
9.8	SHUTTING DOWN THE MACHINE FOR LONG PERIODS -----	9-11
10	TROUBLESHOOTING -----	10-1
10.1	THE MACHINE DOES NOT START -----	10-1
10.1.1	ALARM/ERROR messages on display -----	10-1
10.2	THE MACHINE STOPS ABRUPTLY -----	10-11
11	MAINTENANCE AND REPAIR -----	11-1
11.1	GENERAL INSTRUCTIONS -----	11-1
11.2	MAINTENANCE SCHEDULE-----	11-2
11.2.1	General maintenance (Daily)-----	11-3
11.2.2	General maintenance (40 hours)-----	11-4
11.2.3	General maintenance (125 hours)-----	11-5
11.2.4	General maintenance (500 hours)-----	11-5
11.3	FUNDAMENTAL MAINTENANCE OPERATIONS -----	11-6
11.3.1	Verification of the lifting unit’s pinion -----	11-6
11.3.2	Inspection of the mast rack-----	11-7
11.3.3	Inspection and maintenance of guide rollers -----	11-8
11.3.3.1	Inspection of nylon guide rollers-----	11-9
11.3.3.2	Replacement and adjustment of front/rear guide rollers-----	11-10
11.3.3.3	Replacement and adjustment of the rack leaf spring guide roller -----	11-11
11.3.4	Verification and adjustment of the air gap of the motor brakes -----	11-12
11.3.5	Servicing the gear motors -----	11-13

11.3.6	Lubricating the machine-----	11-15
11.3.7	Calibration of the OVERWEIGHT SENSOR system -----	11-16
11.3.8	Inspection of the base jacks-----	11-16
11.3.8.1	Inspection of the safety buffers-----	11-17
11.3.9	Inspection of cable guides -----	11-17
11.3.10	Inspection of the trailing cable -----	11-18
11.3.11	Inspection of automatic greaser-----	11-18
11.4	TESTING THE SAFETY BRAKE DEVICE-----	11-20
11.4.1	Performing the drop test -----	11-21
11.4.2	Resetting the safety brake device -----	11-23
11.4.3	Maintenance of the safety device-----	11-24
11.5	ELECTRICAL SYSTEM MAINTENANCE-----	11-25
11.5.1	Maintenance of the electrical system rectifiers -----	11-25
11.5.2	Location of limit switches -----	11-26
11.5.3	Inspection of braking resistors-----	11-27
11.6	TECHNICAL SUPPORT -----	11-28
12	WARRANTY-----	12-1
12.1	WARRANTY -----	12-1
APPENDIX A	-----	A
APPENDIX B	-----	B
APPENDIX C	-----	C
APPENDIX D	-----	D
APPENDIX E	-----	E
APPENDIX F	-----	F
APPENDIX G	-----	G

This page has been left blank for formatting purposes

CHAPTER 1: INTRODUCTION

Record of modifications

Revision	Executor	Date	Description of modification

1 INTRODUCTION

1.1 USE AND MAINTENANCE INSTRUCTION MANUAL

1.1.1 The importance of the manual

Whilst thanking you for choosing a machine from the MAX CLIMBER range, manufactured by BETA MAX, we would like to remind you that this manual is an integral part of the machine itself; therefore, you must look after the manual throughout the operational life of the product and hand it over to any other user or subsequent owner, who has the duty to ask for it and the right to obtain it.

1.1.2 Conserving the manual

The manual must be carefully kept away from humidity and heat. It is to be used in such a way so as not to damage the content or alter the format.

For no reason whatsoever, do not remove, tear, or rewrite any parts of the manual.

1.1.3 Consulting the manual

The manual is essentially divided into the following:

- identification page or “OVERVIEW” showing the version of the manual and the date of issue
- index by subject
- instructions and/or notes on the product
- enclosures

This manual contains warnings that will draw the operator’s attention to a particular procedure or function.

NOTE: these are warnings to guide and optimize the operator’s actions or to better highlight particular characteristics of the machine

ATTENTION: these are very important warnings that specify which actions are to be done, not to be done, or particular precautions which are to be taken before operating the machine in order not to cause damage to it

DANGER: these are extremely important warnings that specify which actions are to be done, not to be done, or particular precautions which are to be taken before operating the machine in order to not harm people

NOTE:

The manual must be carefully read and understood by the various operators, before carrying out their duties and responsibilities when handling the machine.

The instruction manual for the use and maintenance of the machine is intended for:

- the machine user
- the owner
- the site manager where the machine is installed and used
- assigned staff for assembling and disassembling the machine
- the maintenance staff
- the operators
- the people in charge of its displacement

It is mandatory for the instruction manual to be read before handling, installing, using, carrying out any maintenance or shutting down the machine; therefore, it is necessary to keep this manual intact over time by conserving it in a safe place and making copies for frequent use. Handling, installing, using, carrying out maintenance or shutting down the machine may constitute a danger if not carried out according to the requirements of this manual or without due caution and attention, which such actions require.

1.2 PURPOSE OF THE USE AND MAINTENANCE INSTRUCTION MANUAL

This manual provides the necessary information for the proper use of the machine, allowing you to carry out the following operations:

- INSTALLATION
- OPERATION
- MAINTENANCE
- SHUTTING DOWN

NOTE:

If the warnings and suggestions presented in this manual, regarding the above-mentioned operations, are not complied with, BETA MAX cannot be held responsible for the safety, reliability, and performance of the machine.

NOTE:

Failure to meet the requirements stipulated in this manual relieves the Manufacturer and Distributor from responsibility, or any incidents pertaining to such negligence.

Moreover, it is to be noted that in any of the instances listed below:

- improper use of the machine
- untrained staff using the machine
- total or partial non-compliance with the instructions contained in this manual
- non-compliance with national regulatory specifications pertaining to safety at work
- installed incorrectly or with configurations that are not permitted
- defects in power supply
- non-compliance with the instructions concerning the scheduled maintenance operations
- unauthorized modifications or interventions carried out on the machine
- use of spare parts other than those provided by BETA MAX, Inc

BETA MAX, Inc. will not be held liable for risks caused as a result of non-compliance with such requirements. The manual cannot be used as a reference if the intention is to carry out modifications that affect the machine's configuration. However, the Company retains the exclusive responsibility pertaining to any manufacturing defects.

NOTE:

The correct use of this machine entails the precise knowledge of these usage instructions and all the risks related to improper use of the same machine.

DANGER:

The purchaser or the user of the machine bears full responsibility for shutting down the security/safety systems or all that provided by the Manufacturer for the safety of the users and operators.

1.3 UPDATES OF THE MANUAL

This instruction manual reflects the condition of the machine as at the time the machine was marketed and sold; it cannot be considered inadequate solely because it has been subsequently updated based on newly acquired knowledge. BETA MAX, Inc. reserves the right to upgrade its products and manuals, in line with its policy to continuously improve product quality, with no obligation to upgrade previous productions and manuals, with the exception of particular cases.

The edition of an updated version of the use and maintenance instruction manual will not oblige the manufacturer to update this manual, except in the instance of new regulations being introduced, which narrow down the danger posed by the machine during its operation, or upgraded features are installed. In these instances, BETA MAX, Inc. undertakes to provide the Client with a new version of the manual.

1.4 DEFINITIONS

The following definitions will be found in the descriptions within this manual:

- USER.
 - OPERATOR.
 - MACHINE.
- “USER” refers to the person who, due to his qualification, is appointed as site manager where the machine is installed or the person who is directly responsible for the security of the place where the same machine is installed.
- “OPERATOR” refers to the person who, due to his qualification, is designated to install, operate, use, carry out maintenance works, clean, repair or transport the machine.
- “MACHINE” refers to the Transport Platform/Material Hoist with a rack drive system mounted onto masts, with the brand name BETA MAX MC2500TPM-MV model, in all its possible conformations and configurations. From this point onwards in this instruction manual, when reference is made to the Transport Platform/Material Hoist MC2500TPM-MV model, solely “MACHINE” will appear.

ATTENTION:

The operator assigned to work on the machine must be trained on how to use the machine, the safety devices and the installed equipment and accessories correctly. The operator must always wear the specific, individual protection gear and clothing which is appropriate from a safety point of view and also adequate for the type of work that is to be carried out (gloves, ear plugs, safety shoes, safety harness, hard hat, goggles, etc.).

1.5 PREREQUISITES FOR THE MACHINE USER

The information contained in this manual must be supported by the work being carried out well and applying firm principles of safety, training, inspection, assembly, maintenance, implementation, and operation, consistent with all the data available, pertaining to the parameters of usage required and consideration of the surroundings and environment in question. Given that the user has direct control over the machine's operation and its functions, it is his responsibility and that of his staff to ensure that these comply with the necessary safety requirements. Any decisions regarding the use and operation of the machine must always be taken after having considered that the same machine can carry persons as well as material. The safety of the people who work on the machine or nearby, depends on such decisions.

1.5.1 Use and maintenance training

The user must train his maintenance staff on how to inspect, assemble and carry out maintenance on the machine in accordance with the sections in this manual pertaining to the Manufacturer's instructions and recommendations.

1.5.2 The user's responsibility

Whenever a user assigns or authorizes an individual to operate the machine, it is his responsibility to ensure that the individual in question has been trained in accordance with the requirements stipulated in this manual under the sections pertaining to the installation and operation, together with the working knowledge imparted by the user himself.

1.5.3 Training on the particular model of machine

The user is responsible for training the operator on how to use the particular model of machine he is to work on. Such training must take place in an area that is free from any obstruction, under the direction of a qualified person and for a period of time which is long enough to ensure that the person being prepared is competent to use the machine.

Only members of staff who have been well prepared and who are authorized must be allowed to use the machine.

Before allowing an operator to use the machine, the user must ensure that the operator:

- has been well-prepared, by a qualified person, on the purposes and functions of each control
- has read and understood the instructions in this manual and the safety regulations passed on by the user
- has understood all the warnings and instructions provided for the proper and safe operation of the machine, by reading or by means of the explanations given by a qualified person
- has understood that the machine is to be used in accordance with the applications defined by the Manufacturer

1.6 PREREQUISITES FOR THE ASSIGNED OPERATOR

The information contained in this instruction manual must be supported by sound judgment, appropriate safety checks and caution in assessing every situation.

Since the operator has direct control of the machine, it is his responsibility to comply with the safety requirements in question. The operator must take decisions on the use and operation of the machine, bearing in mind that his personal safety, just like that of the staff members working on the same machine (only during installation and disassembly) and in the vicinity, depends upon his decisions.

1.6.1 Preparatory information

The operator must be aware that this instruction manual is found on the machine and must know where it is placed exactly. The operator must be confident in referring to the manual placed on the machine and must consult it whenever he is faced with doubts or questions regarding the safe and proper use of the machine itself.

1.6.2 The operator's training

The operator must be trained either on the same model of machine or on a model that has characteristics of operation and control that correspond with the machine that is to be used. The operator must operate the machine in an area that is free from any obstruction, under the direction of a qualified person and for a period of time which is long enough to ensure that the person being prepared is competent to use the machine. Only members of staff who have been well prepared and who are authorized must be allowed to use the machine.

Before being given authorization to use the machine, the operator must have:

- been trained by a qualified person, and understands the purpose and function of each control
- read and understand the instructions for the proper use of the machine and the safety regulations, or been trained on the contents of the instruction manual and the above-mentioned regulations by a qualified person
- understands all the warnings and instructions found on plates and tables on the machine, after having read this instruction manual or by means of the explanations given by a qualified person.

This page has been left blank for formatting purposes

CHAPTER 2: GENERAL INFORMATION

Record of modifications

Revision	Executor	Date	Description of modification

2 GENERAL INFORMATION

2.1 IDENTIFICATION DATA OF THE MANUFACTURER AND THE MACHINE

Manufacturer: Maber Hoist SRL Via dell'Industria e dell'Artigianto 35010 Carmignano di Brenta	Distributor: Beta Max, Inc. P.O. Box 2750 Melbourne, FL 32902 www.betamaxhoist.com info@betamaxhoist.com
---	---

Type: PERSONNEL HOIST

Model: MC2000PMB V

Serial Number: _____

Year of Manufacture: 20_____

2.2 MACHINE IDENTIFICATION PLATE

The identification plate of the machine is placed on the inside of the loading unit. The plate allows clear identification of the type of machine, the manufacturer, the serial number and the fundamental characteristics of the machine.

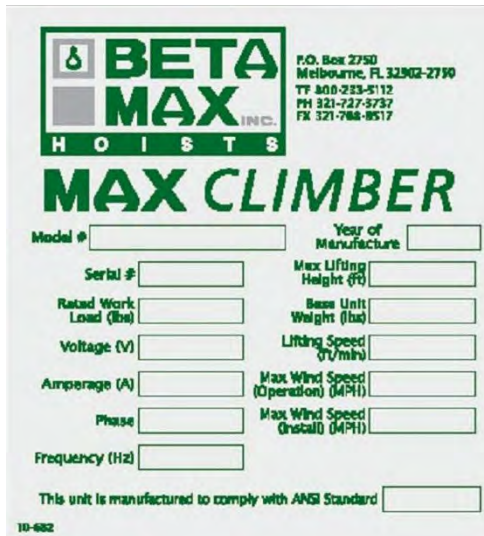

BETA MAX HOISTS INC.
 P.O. Box 2750
 Melbourne, FL 32902-2750
 TF 800-233-5132
 PH 321-727-5737
 FX 321-768-8517

MAX CLIMBER

Model # Year of Manufacture

Serial # Max Lifting Height (ft)

Rated Work Load (lbs) Base Unit Weight (lbs)

Voltage (V) Lifting Speed (ft/min)

Amperage (A) Max Wind Speed (Operation) (MPH)

Phase Max Wind Speed (Install) (MPH)

Frequency (Hz)

This unit is manufactured to comply with ANSI Standard

10-682



Figure 2.1

2.3 IDENTIFICATION SIGN

The machine is identified by means of the identification sign MC2000PMB V where:

- the prefix “MC” stands for Max Climber, that refers to a Rack and Pinion Hoist
- the suffix “PMB” stands for PERSONNEL & MATERIAL BASKET (machine used to transport persons and materials)
- the numerical suffix “2000” means that the rated load of the machine is 2000 lbs.
The machine is used to transport persons and materials governed by ANSI A10.4, a maximum of 7 people or 2000lbs are allowed on board
- the suffix “V” stands for a variable frequency drive control system

The MC2000PMB is a personnel hoist with a vertical triangular supporting mast, designed to reach a maximum mast height of 500 feet.

Since the machine has been created with characteristics which are totally modular, whichever height of assembly is reached (up to the max. height of 500 ft.) identical modules are to be used (masts, wall anchors etc.).

NOTE:

Depending on the size of the structure or the work arrangement, BETA MAX machines may be equipped with various gear-motors for the lifting unit and the mast section may be triangular or rectangular.

The descriptions provided further on, and the relative illustrations may show machines which have characteristics that are different from those of the machine referred to in this manual. This applies solely and exclusively to all the general descriptions, where reference is not made to fundamental details for understanding machine operation and more importantly, all descriptions of the machine's safety systems.

This page has been left blank for formatting purposes

CHAPTER 3: MACHINE INFORMATION

Record of modifications

Revision	Executor	Date	Description of modification

3 MACHINE INFORMATION

3.1 PREFACE

The machine has been designed and manufactured in accordance with the highest standards of quality and safety. The manual provides instructions and recommendations to the operator and qualified assigned staff, in order for them to safely control all situations when the machine is used, allowing them to carry out the service and maintenance required on the product itself. This use and maintenance instruction manual must be available to the members of staff who work on the machine throughout its service life.

The designs shown are for illustration purposes only and do not necessarily represent the products on the market. These products must be used in accordance with applicable experience and safety regulations. The specifications of the products and parts shown in this manual are subject to change without giving prior notice.

3.2 GENERAL DESCRIPTION

The machine is designed and constructed in accordance with the following laws (when and if applicable):

- ANSI/ASSE A10.4 – American National Standard: Personnel Hoists and Employee Elevators on Construction and Demolition Sites.
- MACHINE DIRECTIVE 2006/42/CE
- ELECTROMAGNETIC COMPATIBILITY 2004/108/CE
- LOW VOLTAGE DIRECTIVE 2006/95/CE
- EN 12159:2009 – Builders Hoists for Persons and Materials with vertically guided cages.
- UNI EN ISO 12100-1: 2009 - Machinery safety - Fundamental concepts, design general concepts - Part 1: Base terminology, methodology.
- UNI EN ISO 12100-2: 2009 - Machinery safety - Fundamental concepts, design general concepts
- CEI EN 60204-1 - Machinery safety - Electric devices of the machine - Part 1: General rules.
- UNI ISO 4302 - Raising devices - Wind's load
- UNI 7670 – Mechanisms for lifting appliances. Instructions for design.

The following description explains in detail the appropriate use of the machine and presents the various components used in the same machine. For specific information about the operational procedures please refer to the contents found in the specific chapter, further on in this manual.

3.3 MACHINE LAYOUT

The dimensions shown in figures 3.1 and 3.2 are for the MC2000PMB V.

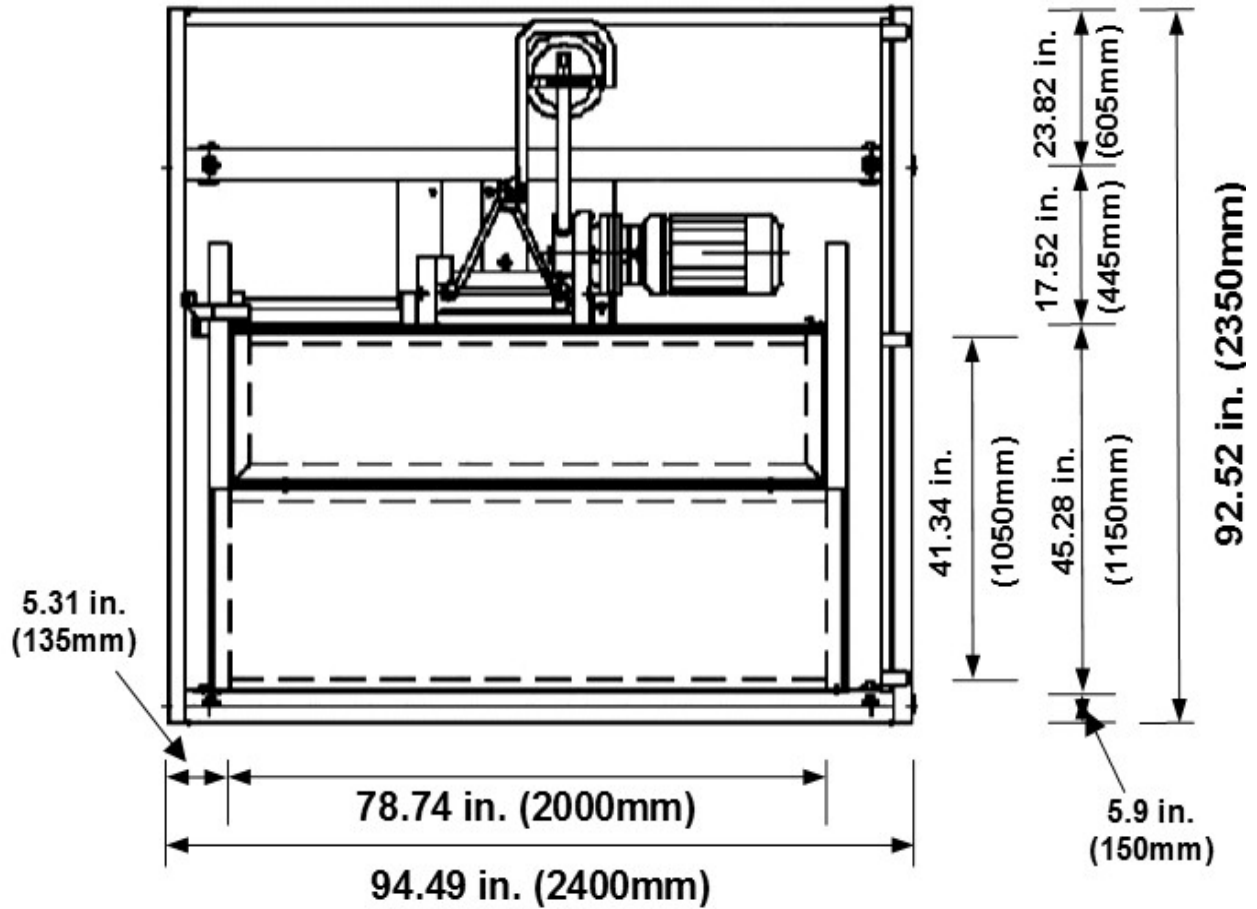

Figure 3.1 Unit with 500mm drum

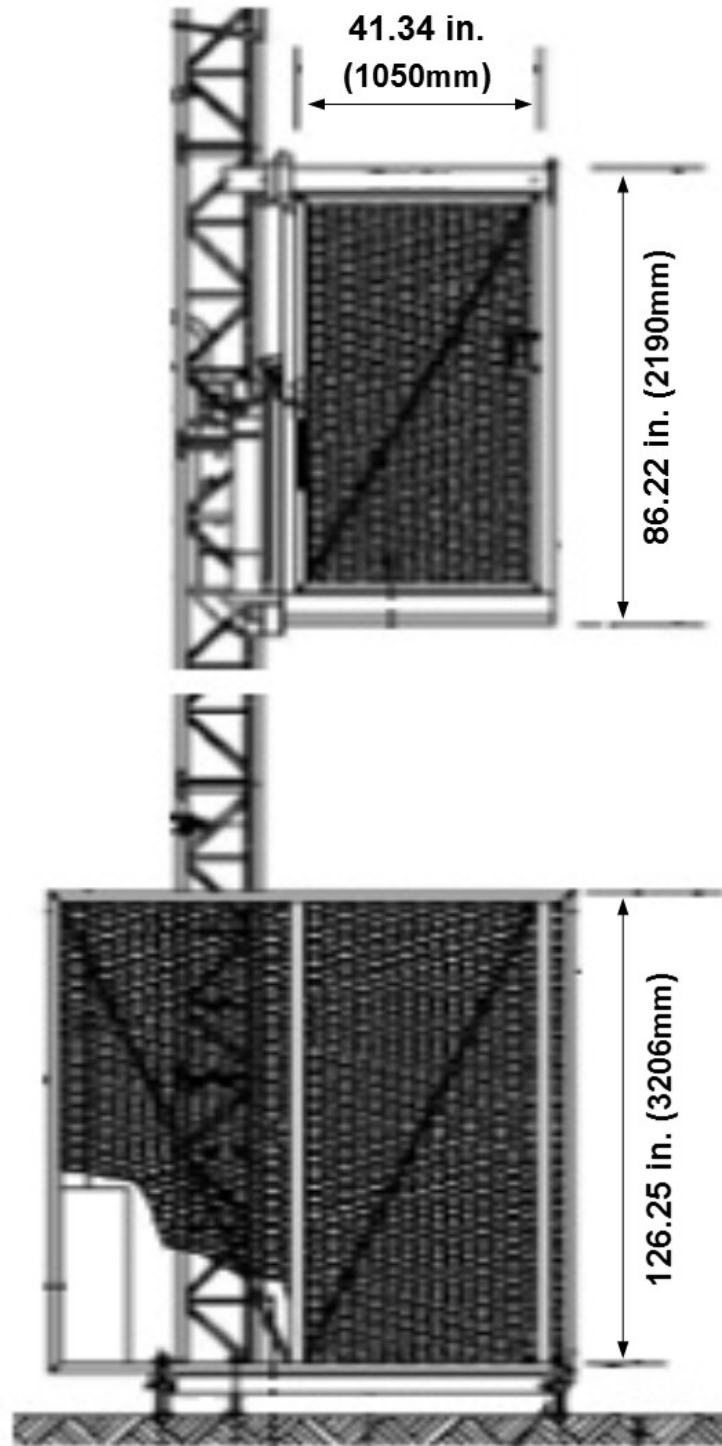
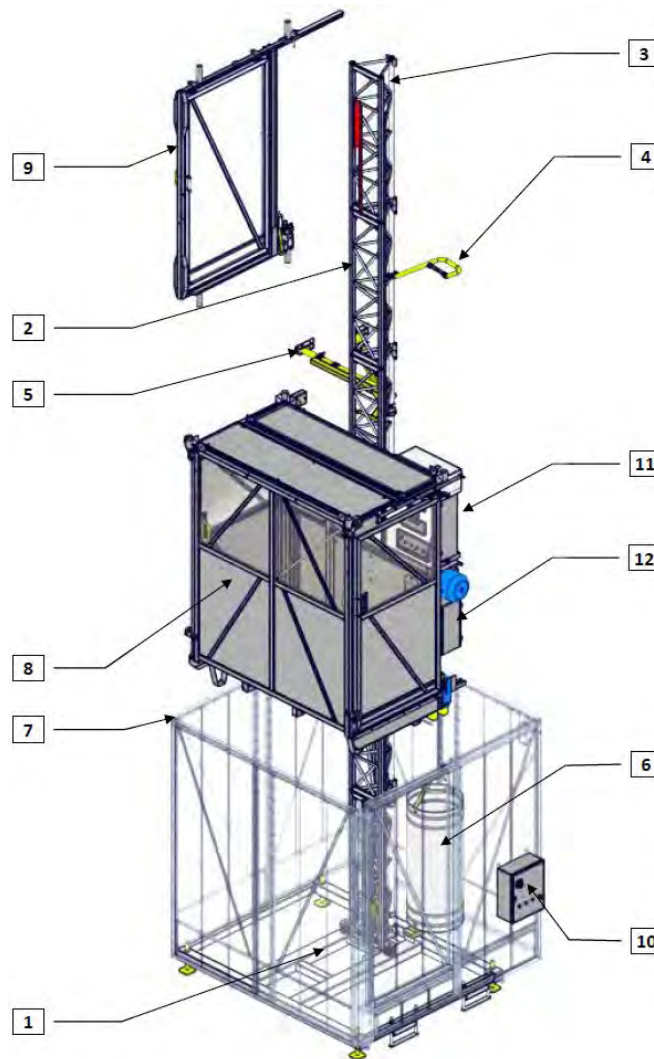

Figure 3.2

3.4 DESCRIPTION OF THE MACHINE

The main sections of the machine shown in figure 3.3 and listed in the legend below are then described in detail in the subsequent paragraphs.



- | | |
|-------------------|------------------|
| 1 Base | 7 Base Enclosure |
| 2 Vertical Mast | 8 Loading Unit |
| 3 Top Safety Mast | 9 Landing Gate |
| 4 Cable Guide | 10 Ground Panel |
| 5 Tie Assembly | 11 Cage Controls |
| 6 Cable Drum | 12 VFD Panel |

Figure 3.3

The machine consists of a base unit made of steel sections and acts as a support on the ground while sustaining the entire vertical part of the machine. The base unit is equipped with a leveling system to be leveled with the flooring and a vertical mast tower with triangular sections on which the lifting unit travels and in turn supports the loading unit.

The loading unit is paneled with aluminum sheets and has dumping doors to give access to the material and personnel onto the landing platform.

The mast is made of modular elements which allow the machine to reach a maximum height of **500 ft.** The parts are easily and safely assembled by the personnel working from inside the cabin. The attachment of the vertical mast to the structure is secured by adequate anchor structures and the erector's platform is used for their assembly.

The loading unit is lifted by means of a gear motor with a self-braking electric motor that employs a rack that is solidly connected to the mast. The motor unit, powered by an electric cable gathered at the base of the machine in an appropriate container, is controlled by electric control panels onboard the machine and on ground level outside the base unit.

If the machine is equipped with a floor-level calling system, the electric power cable also includes conductors for the drive signal.

In the instance of a power failure or a technical fault, the gear-motor is equipped with a manual brake release for the electric motor. This device allows the cabin to be lowered by gravity until adequate safety conditions are reached in order to carry out work on the machine.

The machine is equipped with an emergency progressive brake (safety brake), which is activated if the gear-motor malfunctions or in case of an excessive speed of descent.

Hereunder are the descriptions of all the machine's components; those supplied as standard as well as optional components which the client may opt for or may be specifically required due to particular legislation in some countries.

3.4.1 Base unit

The base unit is the structural component which rests on the ground and supports the mast and the base enclosure unit. It is made of structural steel sections connected by electric welding and screws.

Other than supporting the mast and base enclosure unit, its function is that of spreading the machine's overall weight evenly on an extensive foundation area. To the basement are applied five leveling screws which, with the help of a level, allow putting the tower in perfect upright position even on sloping grounds.

If the machine is used without the mast being anchored, the base unit must be properly set into the foundation; for example, with toggle bolts or lag bolts sunken directly into the cement (for this particular operation, please refer to the relevant paragraph in this manual).

The base unit is protected against corrosion by means of hot galvanization.

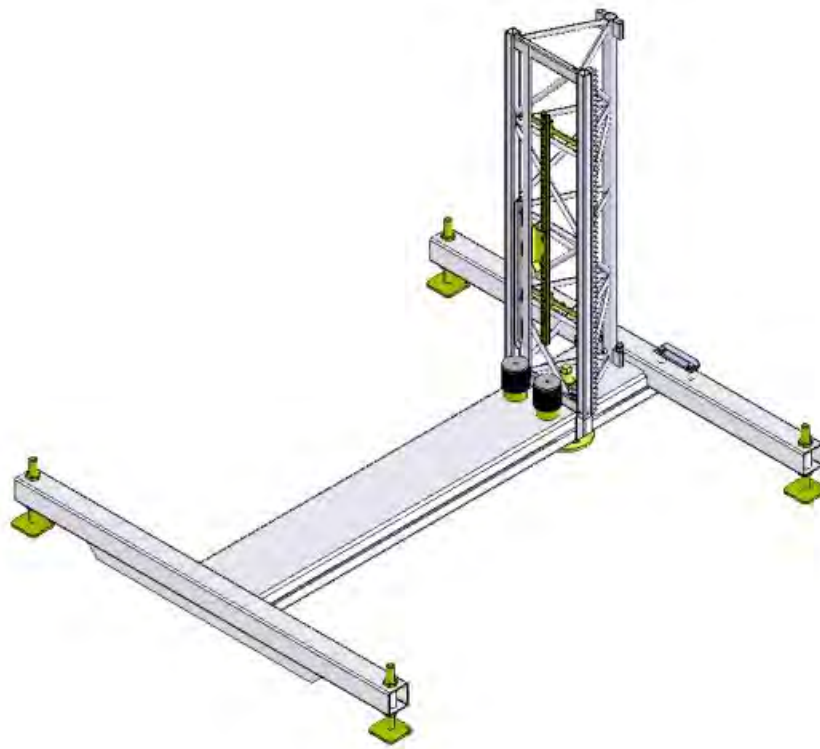

Figure 3.4

3.4.2 Base enclosure

The function of the base enclosure is to prevent persons or material from being in the machine's path, even accidentally, posing the danger of being crushed. Each machine once installed must be equipped with a ground enclosure.

The base enclosure supplied by BETA MAX consists of barriers made of metal sections. There is a horizontal sliding door on the side facing the loading unit, equipped with a mechanical and electrical interlock system. The mechanical interlock prevents the base enclosure door from being opened if the machine's loading unit is not stationary and properly positioned in front of it. The electric interlock prevents the loading unit from moving if the base enclosure door is open or not closed properly.

The base enclosure is protected against corrosion by means of an epoxy powder coating and hot galvanization

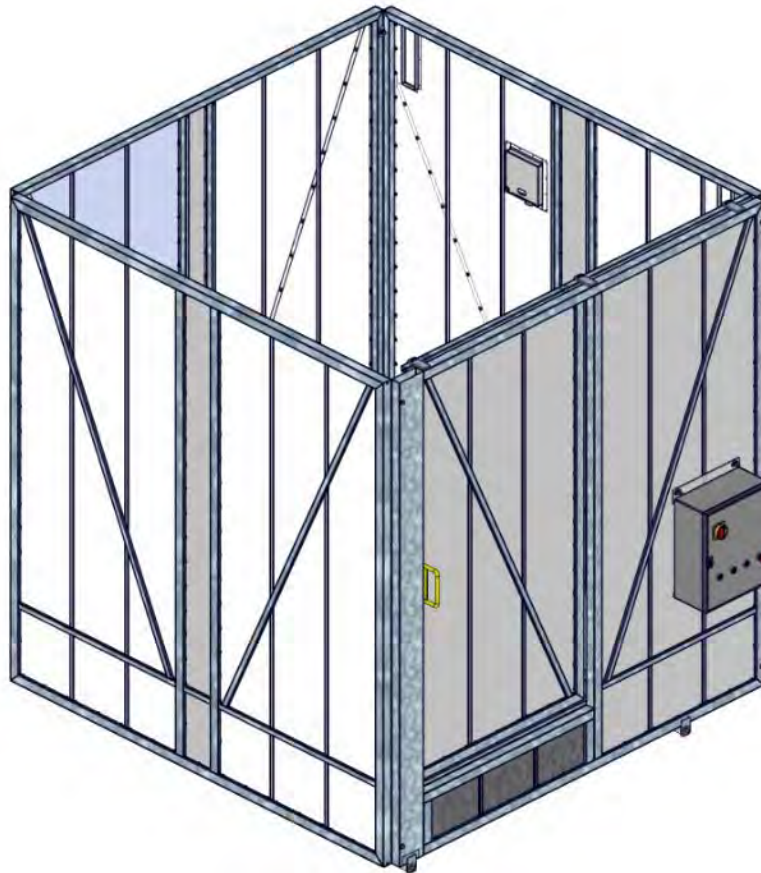

Figure 3.5

3.4.3 Vertical mast unit

The machine uses a triangular section mast. The mast is an upright prism measuring 14.2 inches by 14.1 inches and 58.8 inches in height. The mast is a lattice beam consisting of three main vertical supports with two rectangular tubes of 1.57in x 1.57in and one with a circular cross-sectional rod having a diameter of 1.89 inches, joined together by electro-welding, made of reinforcing tubes and other metal sections. The rack is a modular 7 and welded onto one of the main vertical supports, and at the two extreme ends of the mast there are the connecting flanges, which join the other masts. These are joined by means of bolts and nuts, while the perfectly central alignment is guaranteed by three tapered couplings, which are situated inside the vertical supports. Accurate finishing with a numerically controlled machine tool guarantees perfectly parallel sides of the mast, which are perfectly perpendicular to its main axis. Moreover, this process guarantees perfect conformity when passing through the section where two racks are joined.

The masts are protected against corrosion by means of hot galvanization. Their stability and perfect verticality are secured by the wall anchors, which are available in various types and can cover various distances from the wall. The masts also support the electric cable driving devices and cams, which employ the safety system and the regular stop system of the loading unit.

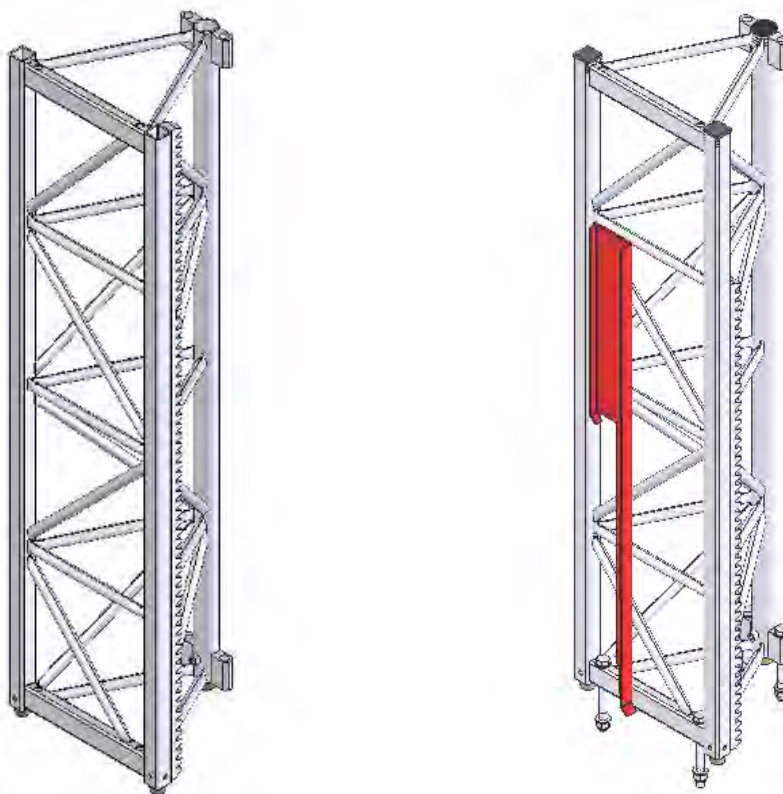

Figure 3.6

3.4.4 Loading unit

The loading unit is further divided into five main subunits: the rear part which interfaces with the lifting unit, the enclosure at the front, the openable roof top, and the two access doors. The rear part is made of a steel frame with aluminum sheet panels, the access doors are made of steel framing with aluminum sheeted panels, the front panel is made of a steel frame with aluminum sheet panels, and the roof top is made of steel framing with steel sheet metal panels. The access doors are equipped with electro-mechanical locks, in order to prevent the doors from opening accidentally when the loading unit is in motion, and electrical switches, which interrupt the command circuit and in turn prevent the loading unit from moving if the doors are open or not closed properly.

The loading unit is connected to the lifting unit through fixed hinges and pins that allow mechanical removal.

The loading unit is protected against corrosion by means of hot galvanization.

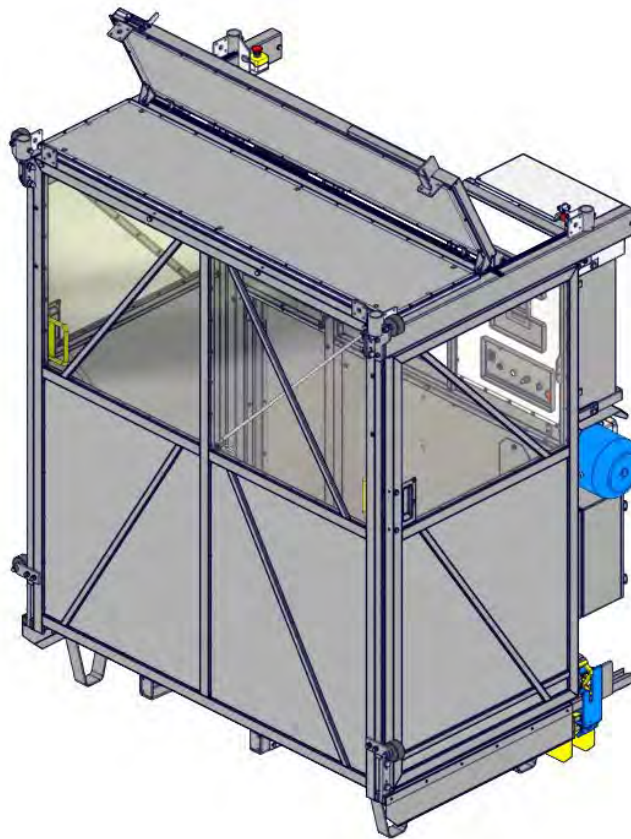

Figure 3.7

3.4.5 Lifting unit

The lifting unit is made from metal sections joined with electro-welding and travels along the mast while being held in drive-motion by a series of small wheels on the border of the mast's rails. The motion is guaranteed by mesh of gear (1) with the rack which is welded to the mast. Safety hooks, placed under the gears, have the function of preventing the lifting unit from coming out of its drive mechanism and plunging down should the pin of one or more small sliding wheels happen to break, or if the cabin goes past the last mast installed due to a fault in the loading unit's control system.

All the machine's systems of movement, control and safety are installed on the lifting unit; the safety hooks (2), the guide rollers (3), the safety brake system with encoder (4), the gear motor (5), and all the safety and control devices such as the up stop limit switch (6), the upward slowdown limit switch (7), the down stop limit switch (8), the downward slowdown limit switch (9), the up over-travel limit switch (10), the down over-travel limit switch (11), and the mast presence proximity switch (12). The lifting unit is protected against any corrosion by means of hot galvanization.

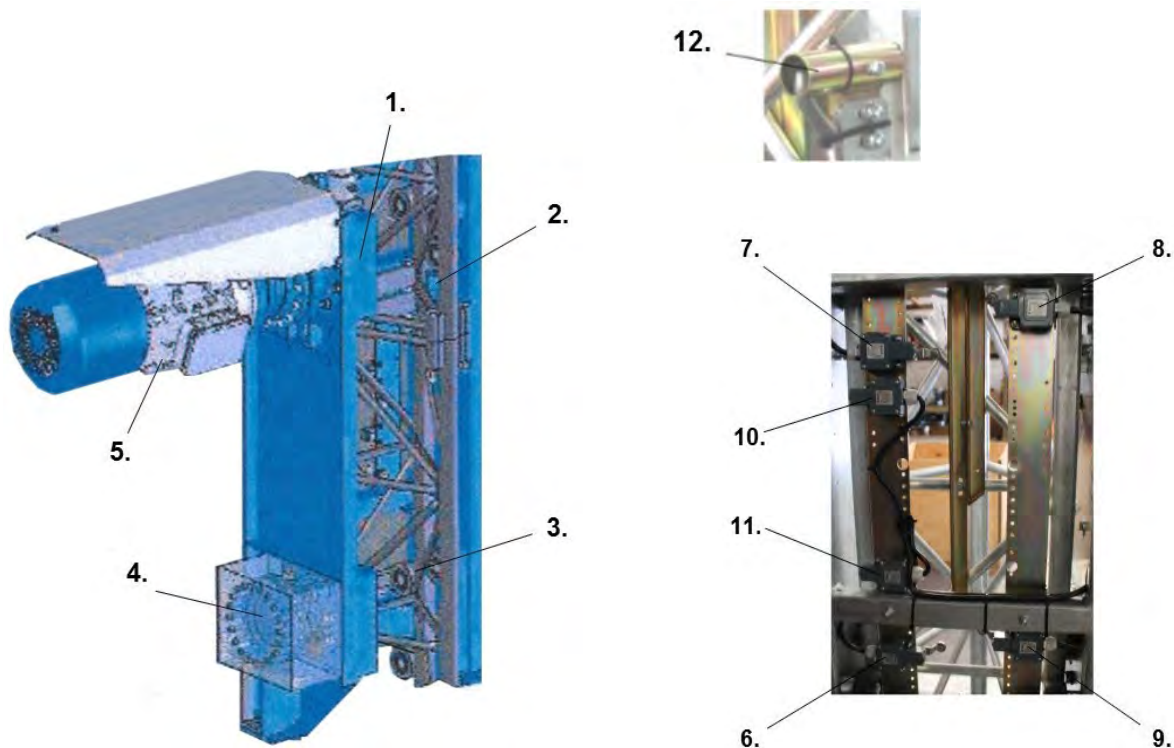

Figure 3.8

3.4.6 Floor landing unit

The floor landing equipment consists of full height sliding doors (figure 3.9) or full height hinged doors (figure 3.10), which are designed to prevent accidental access to the machine's path and supply proper protection to prevent accidental falling of persons or materials present on working floor.

The doors at the floor level are installed in the building, close to the machine's path and must interface with the loading unit, supplying a safe passage from the floor to the machine and vice versa. They can also be equipped with an electrical interlock system that will prevent the machine from operating if the doors are open. This characteristic avoids the possibility that the operator could move the machine before having closed the door and therefore prevents it from leaving the area without protection.

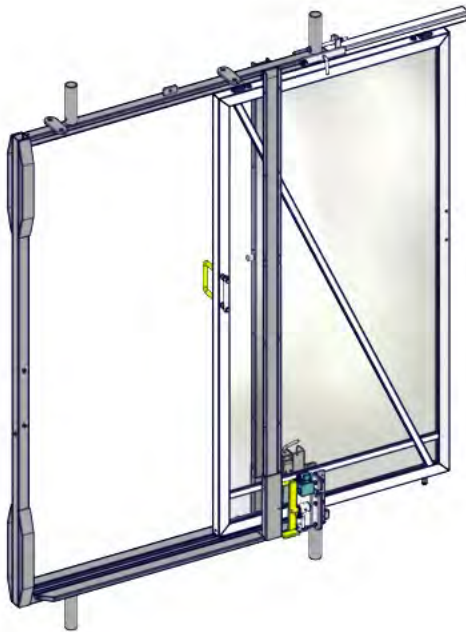

Figure 3.9

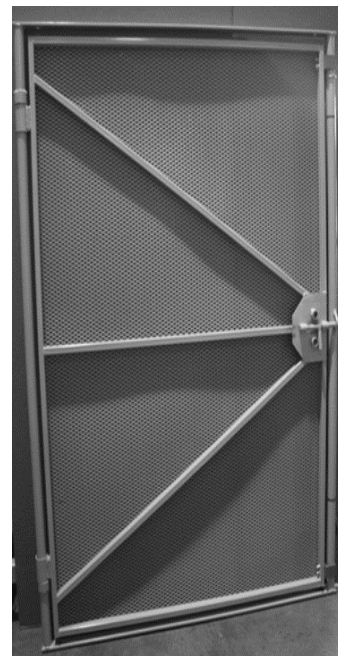

Figure 3.10

3.4.7 Electric cable guide unit

In order to prevent the electric cable from getting caught on to the mast, an anchor, the rough edges of the building, etc., because of the wind, and consequently ripped from the moving cabin, the machine is equipped with an electric cable guiding system. This system is composed of:

- electric cable container
- electric cable guide frames

The electric cable container coils up the electric cable at the base, in a safe and orderly manner according to the natural coil of the cable itself, ensuring it is wound and unwound adequately. The electric cable guide is made of a metal frame that is fixed to the rod on the rear side of the mast, at regular intervals (depending on the windiness of the area where the installation is carried out). The end part of the cable guide forms a sort of ring shape, with one side made of two supports in flexible rubber. The electric cable that is supported and driven by the lifting unit, passes from the inner part of these rings situated all along the machine's path and is contained very well in order to prevent it from swinging sideways.

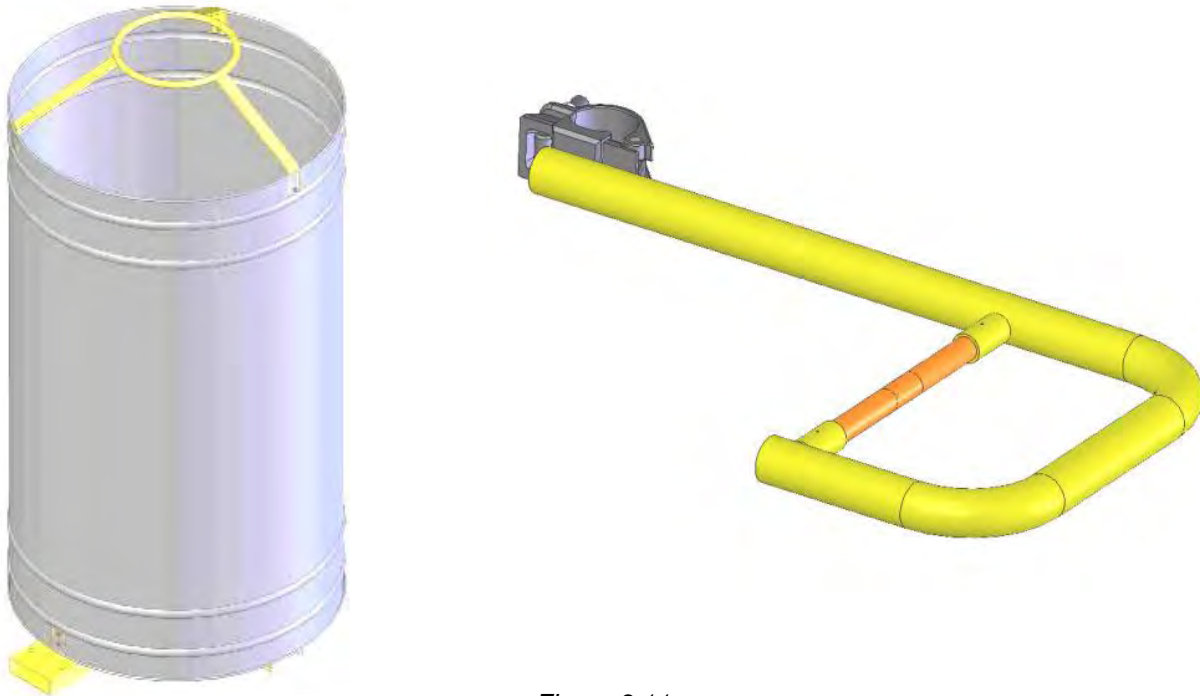

Figure 3.11

3.4.8 Electrical equipment

The electrical equipment supplied as standard with the machine, complies with and is designed according to standards and regulations. The electrical equipment can be different for each machine, in accordance with the specific rules and regulations of the destination country of the machine. The electrical equipment is also designed according to the particular operating conditions of where the assembly will take place (when requested and where possible). All components of the electrical equipment are checked, tested and in conformity with the following national and international standards: IEC, CEE, EN, DIN, UL, CSA, SS, ISO, and UNI. To satisfy the client's specific demands and comply with the various machinery regulations, the electrical equipment is designed specifically for each machine installation (when necessary). All documentation related to the electrical equipment, including the wiring diagram, list of components, etc. is available in the relevant paragraph of this manual as well as inside the electrical control panel box.

3.4.9 Electrical settings

The machine is equipped with two electrical control panels:

- the BASE CONTROL PANEL (ground box) found on the base unit of the machine
- the ONBOARD CONTROL PANEL (cabin box) found onboard of the loading unit

3.4.9.1 Base control panel

The base control panel (1), supported by an adequate support, is mounted on the machine near the access door of the base enclosure. This control panel supplies power to the machine and to the onboard control panel and also serves as an interface between the floor-level calling system (when present).

The following components are installed on the base control panel: the main power switch, the control devices, and the connectors to connect the control panels. An appropriate closure cap is supplied for each connector; in case the machine does not have the relative command or control mechanism. Moreover, in order to protect the power line, a circuit breaker is placed inside the base control panel, which prevents a power surge or short circuit occurring in the main electric power cable.

NOTE:

For the detailed description of the mechanisms installed on the control panel, please refer to Chapter 7 "COMMAND AND CONTROL DEVICES" in this manual.



Figure 3.12

3.4.9.2 Onboard control panel

The onboard control panel (1), found onboard the loading unit, has the control function of the machine.

The following components are installed on the onboard control panel: the main power switch, the control and warning devices, and the connectors to connect the control panels and an auxiliary power socket to supply power to an installation transformer.

An appropriate closure cap is supplied for each connector; in case the machine does not have the relative command or control mechanism.

NOTE:

For the detailed description of the mechanisms installed on the control panel, please refer to Chapter 7 "COMMAND AND CONTROL DEVICES" in this manual.



Figure 3.13

3.4.9.3 VFD enclosure panel

The VFD enclosure panel (1), found onboard the loading unit, contains the machine variable frequency drive (VFD). The VFD is the motor controller that allows for the different speeds of the unit while in operation.



Figure 3.14

3.4.9.4 Control keyboard

The floor call box consists of command pushbuttons (button to call the machine up, one to call the machine down, one to stop at the next floor in the operated direction, and a red EMERGENCY pushbutton).

NOTE:

For the detailed description of the controls installed on the control panel, please refer to Chapter 7: "COMMAND AND CONTROL DEVICES" in this manual.

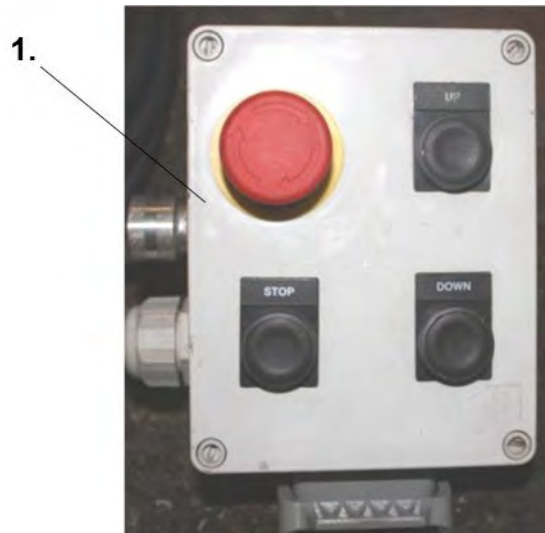

Figure 3.15

3.4.10 Centrifugal safety brake unit

The safety brake is a device, which intervenes and stops the loading unit, smoothly and steadily, in case of an excessive speed of descent. Moreover, the safety brake is equipped with a switch that intervenes by interrupting the power supply of the main contactor after which it will not be possible to put the machine back on until the cause which provoked the intervention is identified and resolved. The safety brake consists of a shaft which bears a pinion at its extreme front end, which is permanently engaged with the rack, while bearing a centrifugal device with a swinging arm that moves with the rotation of the brake housing. If the speed of descent of the loading unit exceeds the threshold set on the safety brake, the arm locks itself from its moving position into a fixed position on the brake housing, engaging with the brake and starts its braking function on the machine. The braking torque transmitted to the pinion is secured by a circular row of springs that are set in the rear part of the safety brake. Irrespective of the load found on the lifting unit, this system guarantees a constant.

The machine encoder is attached and operates with the safety device pinion.

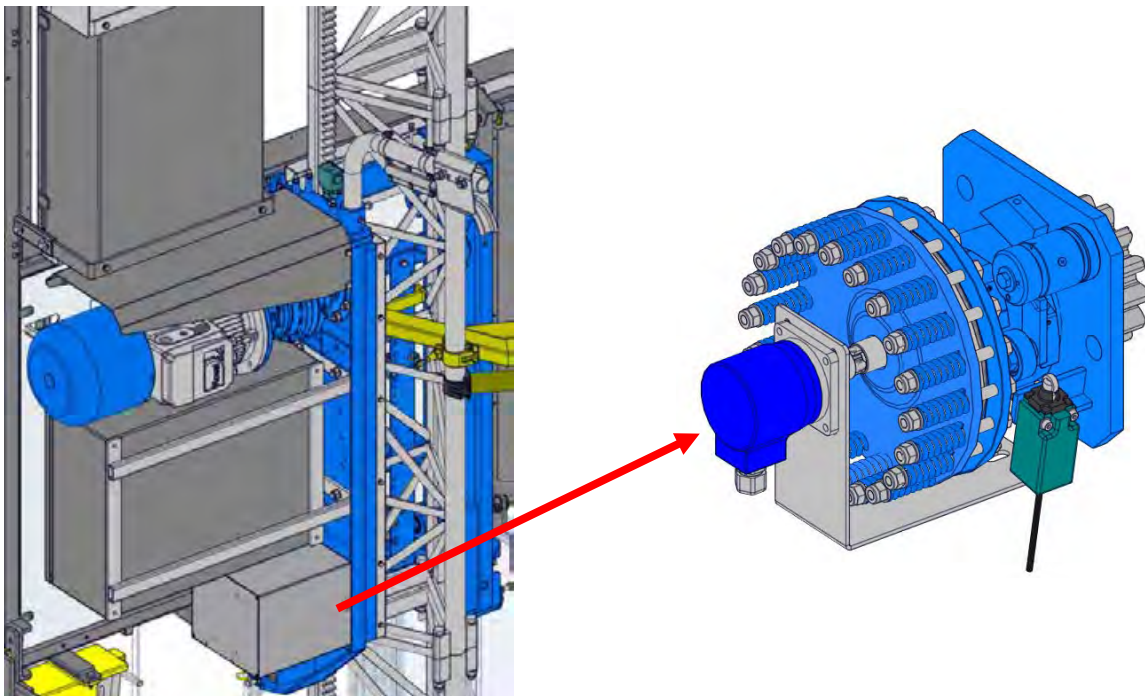

Figure 3.16

3.4.11 Drop test pendant

The machine is equipped with a drop test pendant for the "drop-test" to be carried out. This test makes it possible to verify the functionality of the safety brake system and is carried out with every new installation as well as periodically. After each test, the intervention system must be restored by following the instructions in the relevant paragraph. The safety brake device is equipped with a grease nipple for the swinging arm.

DANGER:

The operator is authorized to carry out the restore operations exclusively as described in the relevant paragraph; any other intervention, disassembly, adjustment, etc. is to be implemented solely by BETA MAX Technical Support, which disclaims all responsibility if it has been tampered with. Since the safety brake is a delicate component of particular importance, it must be sent to BETA MAX Technical Support, every three years to be tested and when its operation mode is restored. The safety brake will be returned with the relevant verification stamp. BETA MAX disclaims all responsibility if the user does not comply with this procedure.



Figure 3.17

3.4.12 Wall anchor unit

If the machine is installed with a height higher than the maximum allowed in free mast, it must always have the vertical component anchored to the structure of the building at regular intervals in order to guarantee complete reliability in respect to safety regulations. The anchors must be set in place by using the proper assembly platform or alternative means as long as these are suitable for this use, such as hydraulic platforms, traditional scaffolding towers or by making use of any balconies the building may have etc. In any case, the operator must be equipped with all the individual protection gear, as expected, such as safety harness, safety shoes, hard hats, gloves etc. Moreover, this operation must be carried out by taking all the necessary precautions based on experience and good practice of those who work with heights. More information and precautions on how to operate will be given further on in this manual. However, the user is obliged to verify the chosen structure's suitability in withstanding the force exerted by the anchors and utilize mounting components such as toggle bolts, which are suitable for the type of wall to which the machine is to be anchored.

The anchor system consists of the following components:

The anchor system for triangular section mast consists of the following components:

- wall anchor extension bar
- wall anchor extension bar

Wall extensions very long can cause problems of rigidity of the anchorage, in these cases is necessary to use a diagonal joint between the extensions.

For a detailed description of the wall anchors, technical specifications, force exerted by the anchors onto the structures, implementation methods and information on all accessories supplied with the machine, refer to the appropriate chapter.

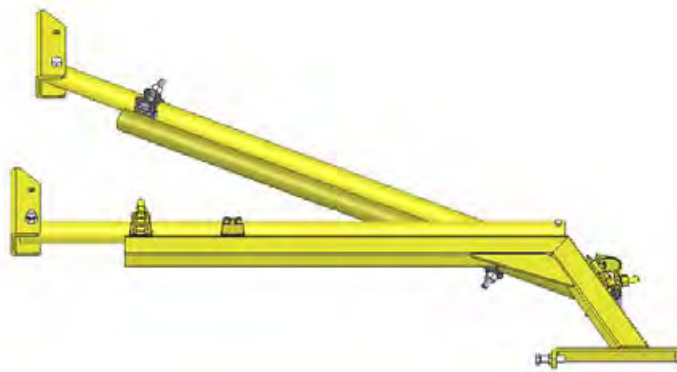

Example of Standard Tie

Figure 3.18

3.4.13 Platform for anchors mounting unit (erection platform)

To perform the mounting of the mast and of the anchorage devices it is possible to operate from the loading unit or by opening a retractable platform.

The mounting platform is a safe and comfortable terrace which stretches towards the wall allowing for easy installation of the anchoring structure. The platform is made of metal profiles and its working platform (1) is made of embossed aluminum sheet metal. The platform used for mounting the anchors is an integral part of the loading unit and can be opened and closed whilst operating in absolute safety from inside it. The platform is conveniently equipped with guard rails on all four sides, in order to prevent the operator from falling off. Mobile parts of the platform are controlled by a switch which prevents the machine from moving if those parts are open or not properly closed. Appropriate hooks for the safety harness, are placed onboard the platform and together with other individual protection gear, are obligatory to be used by the operator when mounting the wall anchors.

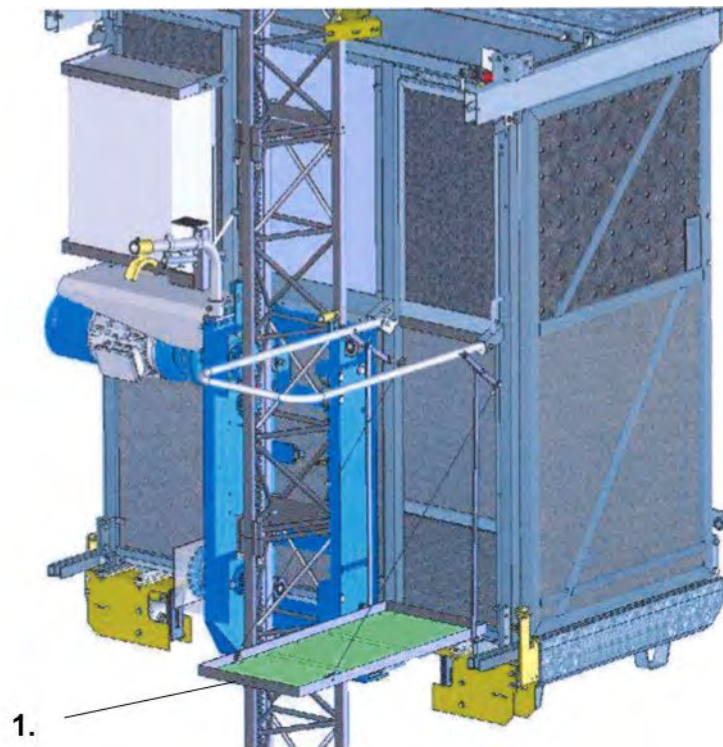

Figure 3.19

3.4.14 Accessories

The machine has different groups or accessory devices which can be supplied and installed upon request. The following accessories:

- overweight (overload) control device
- mast automatic greasing device
- cabin light
- emergency alarm

OVERWEIGHT (OVERLOAD) CONTROL DEVICE

The device acted to check the transported load. It's made essentially of load transducers (1) connected to the loading unit (2), a controller mounted to the side of the onboard control panel (5) containing an acoustic signaling device (3), and an overweight alarm display (4) will show "LOAD WEIGHT" error to warn the operator of the load condition on the onboard control panel (5).

The transducers detect the transported load and by approaching the limit value the alarm will begin to beep when the payload on the machine has exceeded 70% of the maximum payload permitted. The alarm will begin a continuous sound when the payload on the machine has exceeded the maximum payload permitted.

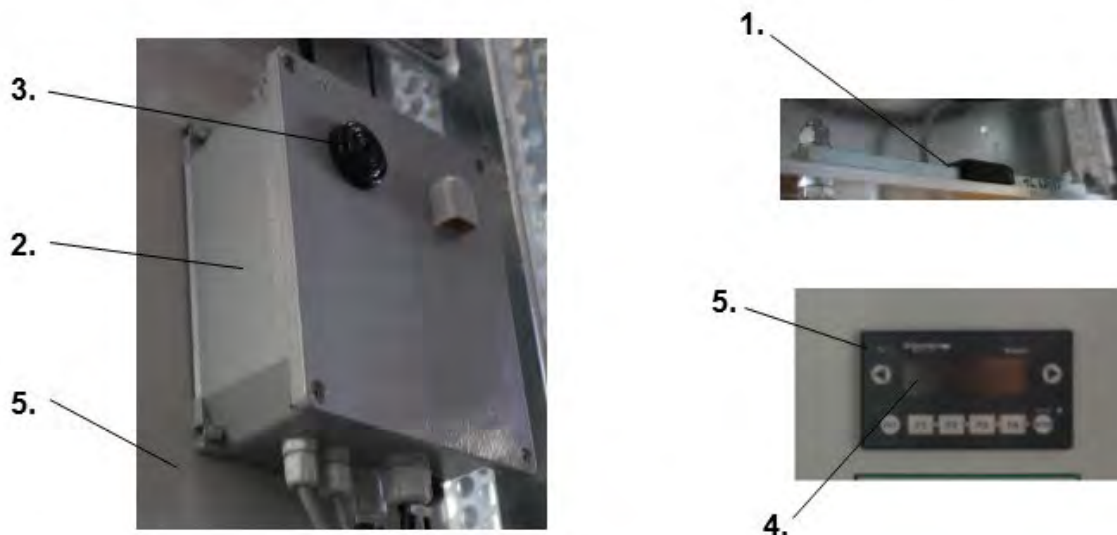

Figure 3.20

MAST AUTOMATIC GREASING DEVICE

The mast automatic greasing device is formed of a container (1) for the solid grease, of a device (2) for the grease distribution and of a tube and brush system (3) to distribute the grease onto the rack of the mast. The device is automatically activated by the movement of the machine depending on the position of the AUTOMATIC GREASER key switch located on the onboard control panel.

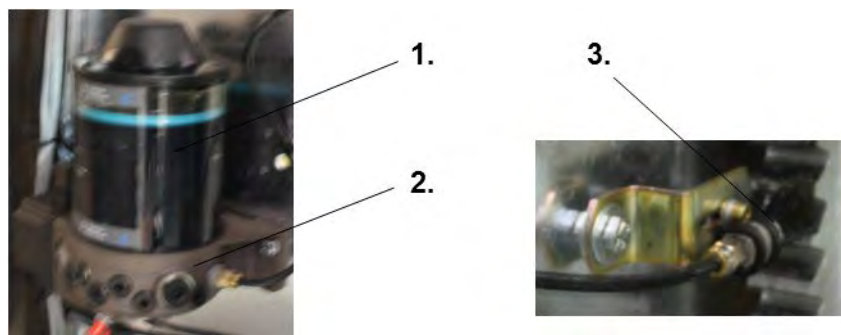

Figure 3.21

CABIN LIGHT

The cabin light is a light to illuminate the loading unit cabin with a battery backup for if loss of power to the machine occurs. The device is controlled by the CABIN LIGHT key switch located on the onboard control panel.

EMERGENCY ALARM

The emergency alarm is an audible signaling device located under the loading unit with a battery backup if loss of power to the machine occurs. The device is controlled by the SIREN/ALARM pushbutton located on the onboard control panel.

3.5 TECHNICAL SPECIFICATIONS OF THE MACHINE

3.5.1 General Data

Lifting speed (Upwards Empty).....	131 ft/min
(Upwards Full Load).....	98 ft/min
(Downwards Empty or Full Load).....	131 ft/min
Safety brake intervention speed.....	138 ft/min
Max. wind speed allowed during installation.....	28 mph
Max. wind speed allowed when in operation.....	40 mph
Max. wind speed allowed when not in operation (machine on the ground).....	78 mph
Number of motors installed.....	1

3.5.2 Electrical specifications of the machine

Lifting power consumption.....	1 x 10 HP
Supply voltage.....	208Vac-3PH-45A
Power frequency.....	60 Hz
Voltage of the controls.....	24 Vac & 24 Vdc
Frequency of the controls.....	60 Hz

3.5.3 Electrical

Lifting power consumption.....	10 HP
Absorbed current.....	35 A
Max. inrush current.....	45 A
Required power line.....	208Vac-3PH-45A
Power cable section.....	see Chapter 6

3.5.4 Manufacturing characteristics of the electric motor

Type.....	self-braking three-phase
Motor size 10 HP.....	132
Construction design.....	B5
Protection against the elements.....	IP55
Number of poles.....	4
Service factor.....	S1
Isolation class.....	F

3.5.5 Technical specifications of electric motor

Rated output.....	10 HP
Revolutions for minute.....	1750
Rated voltage.....	208Vac-3 PH
Rated current.....	30.3 A
Inrush current.....	105 A
Motor connection.....	Wye
Power factor.....	0.76 cos
Frequency.....	60 Hz
Brake rated voltage.....	103 Vdc
Frequency of the controls.....	60 Hz
Motor weight 11 Kw.....	160 lbs

3.5.6 Dimensions and capacities

Loading unit internal dimensions	6.56 ft x 3.45 ft
Loading unit working surface	22.632 ft ²
Rated load	see following paragraph
Number of persons onboard (during assembly)	2
Max. lifting height with anchored mast	500 ft
Max. free-standing height allowed when in operation	see chapter 4
Max. free-standing height allowed when not in operation	0 ft
Max. height of first anchor	see chapter 4
Max. distance between anchors	see chapter 4
Max. height after the last anchor	see chapter 4

3.5.7 Dimensions and weights

Collapsed height for transportation	105 in
Height of the vertical masts	58.8125 in
Rack block	7
Complete base weight	1631 lbs
Complete loading unit weight	2315 lbs
Weight of each vertical mast	95 lbs
Complete wall anchor weight	67 lbs
Base unit dimensions	7.87 ft x 7.71 ft x 10.52 ft
Weight of the complete base unit	3946 lbs

3.5.8 Loads/load capacity

Hereunder are the machine's load characteristics pertaining to persons and material that may be transported.

MC2000PMB may have a maximum of 7 people (including the operator) or 2000 lbs. of weight.



Figure 3.22

3.5.9 Safety equipment

Downward over-travel device.....	YES
Upward over-travel device.....	YES
Downward speed slowdown device.....	YES
Upward speed slowdown device.....	YES
Downward stopping device.....	YES
Upward stopping device.....	YES
Floor-level automatic stopping device.....	YES
Mast presence control device.....	YES
Floor-level calling device.....	YES
Electromechanical anti-fall device (SAFETY BRAKE).....	YES
Electric interlock system for the access doors.....	YES
Mechanical interlock system for the access doors.....	YES
Electric interlock system for the anchors mounting platform.....	YES
Electric interlock system for the base enclosure door.....	YES
Electric motors overload device.....	YES
Power line protection device.....	YES
Phase sequence indicator	YES
Machine mode selector.....	YES
Manual brake release for emergency descent.....	YES
Automatic electric motor brake when power supply is interrupted.....	YES
Overload control device.....	YES

3.5.10 Recommended tightening torques

The table below lists the wrench sizes to be used and tightening torques recommended for the various sizes of bolts that are to be tightened.

Thread size	Wrench size	Tightening torque	
		Nm	Ft-lb
M 6	10 mm	10	8
M 8	13 mm	24	18
M 10	17 mm	47	35
M 12	19 mm	81	60
M 14	22 mm	128	95
M 16	24 mm	198	146
M 20	30 mm	386	285
M 24	36 mm	668	493

The table is applicable to nuts and bolts with a resistance class of 8.8 and having dry threads.

ATTENTION:
 Tighten the M16x160 mast bolts to **180 Nm. (133 ft-lbs.)**

3.6 INTENDED USE

The machine finds specific application:

- for traditional construction work, facade improvement and general maintenance work
- for work that requires considerable height
- to be used together with traditional scaffolding
- to be used together with a crane tower
- for works carried out with climbing formwork technology

The machine is designed to provide the user with the following advantages:

- transport material, persons and work equipment safely, efficiently and economically
- optimize and rationalize the work process in a modern construction site
- easy assembly and disassembly requiring only two people
- safety during operation, assembly, disassembly and when the structure may be repositioned to other parts of the construction site
- conformity with all existing international regulations for this type of machine

DANGER:

Safe operation of the machine is guaranteed only for the functions and material listed in this instruction manual.

BETA MAX disclaims all responsibility if the machine is not used in accordance with the purposes indicated and in conformity with the instructions stipulated in this manual.

3.7 NORMAL CONDITIONS OF STORAGE

Storage of the machine's various components does not require particular environmental conditions. The only recommendation is to store the equipment in a place where water infiltration is avoided as much as possible, as in the long run, this may affect the reliability of the machine's electrical system. Do not cover the machine or its components with synthetic fabrics or plastic in order to prevent condensation from forming. If the machine and its components are stowed when wet, always ensure that the place where they are stowed is adequately ventilated.

3.8 STORAGE CONDITIONS WITH TEMPERATURES REACHING A MINIMUM OF -4

If the machine is stored in a closed and heated place so as to protect it from the elements, no particular precautions need to be taken, as long as the temperature is kept higher than -4°F. After having stored the machine outdoors, with temperatures close to -4°F, it is necessary to check for any structural damage caused by water infiltration and subsequent freezing.

3.9 STORAGE CONDITIONS WITH TEMPERATURES LOWER THAN -4

The following precautions must be taken when storage temperatures are lower than -4°F:

- drain the oil from the gear motor

ATTENTION:

Always remember to put oil in the gear motor before putting the machine back into operation.

- disassemble the brake rectifiers (guaranteed up to -13°F), and mount them once again before putting the machine back into operation, ensuring that they are connected correctly
- when the machine is put back into operation, systematically replace the sealing rings of the gear motor's output shaft, as low temperatures change their conformation and no longer guarantee the sealing effect
- when the machine is put back into operation, systematically replace all bearings, as their protection seals tend to become brittle. Alternatively, when placing the order, you may point out this particular storage condition so that BETA MAX can mount particular bearings which are more suitable
- in order to protect the electrical system from damage caused by low temperatures, disassemble the electrical control panel and the motor cable sheaths and store them in a dry, heated place or either way in a place where the temperature is not lower than -4°F

3.10 AMBIENT WORKING CONDITIONS

The machine is designed and constructed to be used in temperature conditions which are not lower than 5°F. If the machine is used at such temperatures, the only requirement is to use lubricating oil for the epicyclical gear system regarding working temperatures ranging from 5°F to 113°F.

Temperatures lower than 5°F do not provide sufficient reliability from the fitting components of the electric motors, generators, etc. and more importantly from the mechanical behavior of the machine's structural components, as they tend to weaken at low temperatures. Therefore, in either case, do not start-up the machine if the temperature is close to or lower than -4°F.

This page has been left blank for formatting purposes

CHAPTER 4: WALL ANCHORS

Record of modifications

Revision	Executor	Date	Description of modification

4 WALL ANCHORS

4.1 PREAMBLE

The wall anchors are the structural components that confer stability and prevent the machine from tipping over during assembly and disassembly, but above all, they reduce and contain the “slenderness” of the vertical mast, always within specific safety values.

ATTENTION:

A machine installed with a height higher than the maximum allowed in free mast, must always be anchored to the facade of the structure in question.

When a prismatic column is subject to high compressive stresses, or to a peak load (the vertical mast is a classic example) lateral buckling can occur, thus creating very dangerous situations. Such conditions occur when the compressed column is excessively “slender”.

“Slenderness” refers to the ratio of the effective length of a mast to the least radius of gyration of its cross-section.

As mentioned earlier on, the vertical mast usually reaches a considerable height for installation to be carried out, and the ratio between its length and its cross-section results in having an unacceptable “slenderness”. This condition would cause lateral buckling, which would result in structural failure. The anchors are the bond between the mast and the structure in question and prevent such an incident from happening by reducing the free-standing length of the mast to reach safety values. The reason behind this necessary preamble is to (moderately) highlight and stress the importance of the wall anchors.

The next few pages refer to the recommendations and emphasis on operating with utmost attention when handling its implementation, paying particular attention to the quality and type of walling, the choice of mounting components (toggle bolts, chemical dowels, etc.), the actual physical labor required, verification of the effective hold of the mounting components and the layout of the anchors required, in accordance with any particular situations within the construction site.

ATTENTION:

The wall anchors are one of the most important structural components of the machine. They ensure that the vertical mast maintains its verticality and confers its static stability. Integrity and efficiency of the wall anchors must be checked frequently while using the machine. The practical work related to the anchors must be left in the hands of personnel who have particular expertise, and consequently, the efficiency and effectiveness of the hold of the mounting components must be meticulously verified.

DANGER:

An approximate and superficial assessment of the installation conditions is the greatest and most common cause of accidents, often with a fatal outcome.

In any case, the maximum distance allowed between the machine base and the first anchor, and that allowed between all other anchors and also that allowed for the mast after the last anchor, must never be exceeded.

DANGER:

A machine installed with a vertical mast height that exceeds what is described in the section *“Installation requirements with free mast.”* must always be anchored to the facade of the served structure.

Moreover, the operator must be certain of the forces exerted by the anchor system onto the structure in question and verify that this is suitable to withstand them; he must make the right choice when deciding upon the mounting components in accordance with the facade’s walling. If the machine is anchored to traditional scaffolding, the layout must be considered appropriately. Any layout of anchors which is not given in this manual may only be implemented if it has been brought to the attention of and explicit authorization is given by BETA MAX. The implementation of the anchors must be carried out solely by means of the proper mounting platform, or by using methods of equal efficacy and safety, such as hydraulic baskets, traditional scaffolding towers, balconies which the building may have etc. However, individual protection gear must be utilized anyway, such as a safety harness, hard hat, safety shoes and gloves. It is absolutely prohibited to lean over or operate from outside the platform used for mounting the anchors or the loading platform; any operation must be carried out from inside the structures mentioned earlier on, as shown in figure, or by utilizing means which have similar safety features. It is also absolutely prohibited to climb onto and all the more to operate from the vertical mast or any other protruding part of the machine.

BETA MAX disclaims all responsibility in the instance of operating in conditions which are not specifically authorized or all the more in conditions which are specifically prohibited.

4.1.1 Disposition of the machine

The below is an example disposition with all applicable measurements.

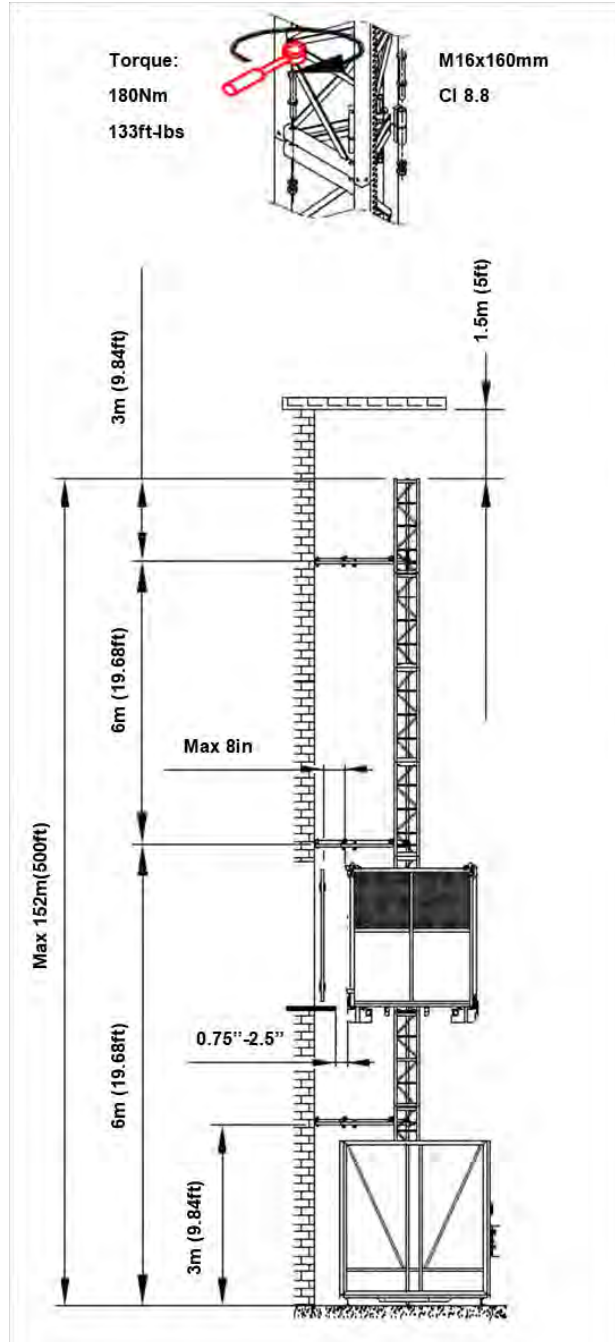

Figure 4.1

4.2 WALL ANCHORS

The wall anchors form the load-bearing structure connecting the vertical components of the machine to either the wall of the building or traditional scaffolding, etc. The wall anchors are coupled to the mast's components by means of clamps and brackets which engage with the vertical uprights of the mast.

The anchor extensions are the components that link the machine's mast to the structure in question. They are coupled to the mast by means of appropriate and approved perpendicular joints and brackets and to the structure by means of appropriate supporting feet. The supporting feet are normally mounted to the wall by means of toggle bolts which are suitable for the type of walling present in the building; it is possible to use other types of mounting components, however, only after an assessment is carried out and decided upon every time, as it depends on the particular requirements of the construction site. These components are also protected against corrosion as they are treated with electrolytic galvanization. The anchor extensions are equipped with mounting plates which are flexible in order to adapt to any facade profile. Optional equipment which may be supplied consists of extension bars which are longer than those mentioned above to allow installations on any type of building or traditional scaffolding, or they may be used for greater distances between the mast and the wall.

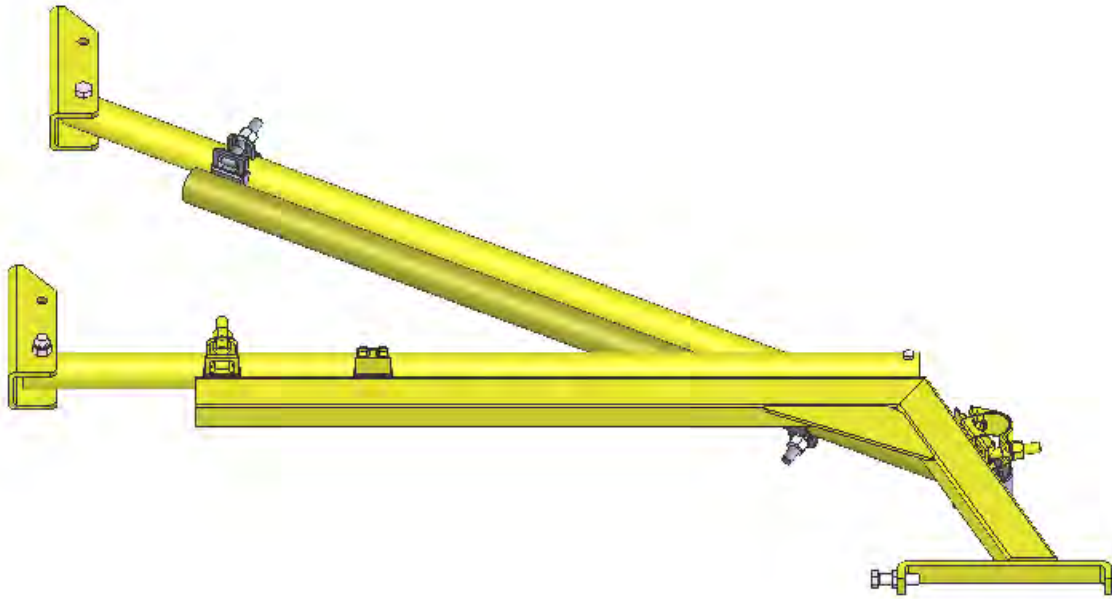

Figure 4.2

4.2.1 Distance between the anchors

The distance between the anchors is determined by several factors such as the conformation of the building to which the machine is to be anchored. It is understood that the maximum distance between two anchors for the MC2000PMB cannot be greater than 19.68 ft.

IMPORTANT!!!

To determine which distances should be applied between the anchors, in any case and always refer to the tables shown in the paragraphs which refer to the conditions of assembling the machine and those of the mast's anchor system, paying attention when choosing the values and maintaining accordance with the options available for the base unit installation. Pay attention to and be certain of which classification of wind the installation area falls under and when unsure, keep to the lowest values.

4.2.2 The structure used for anchoring the machine

It may not be possible to maintain the maximum distance allowed all along the entire mast, even though this is the most feasible anchor system. In fact, it mainly depends on the building's conformation or other situations related to the construction site's particular operational requirements etc. If the distance between the anchors needs to be reduced (the only operation allowed), the user must ensure that the distance between the mast's anchors is as uniform as possible.

DANGER:

IMPORTANT!!! It is only possible to reduce the maximum distance between the anchors.

4.2.3 Allowed height of the topmost part above the last anchor

The maximum free height over the last anchorage must not in any case exceed the height specified in paragraph *"Conditions for anchoring the mast"* irrespective of the type of anchor used. In any case and always refer to the layouts and tables shown further on, bearing in mind to be certain of which classification of wind the installation area falls under and when unsure, keep to the lowest values.

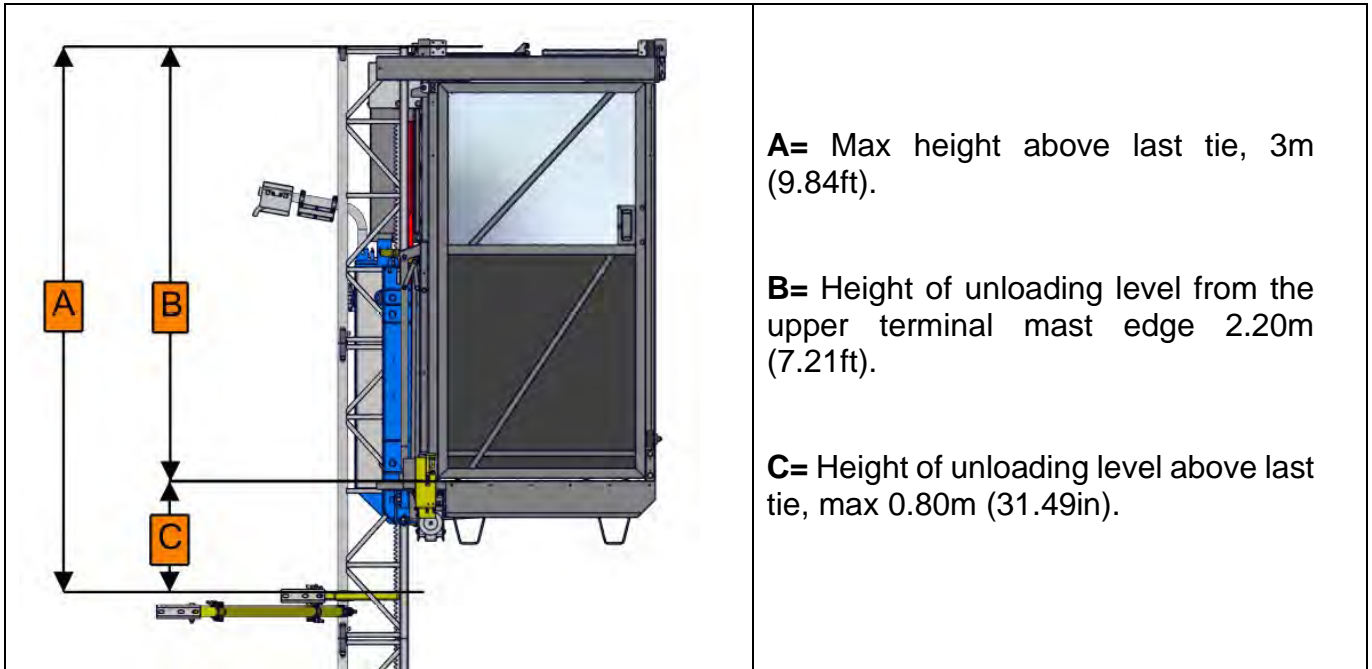

DANGER:

An incorrect assessment of the installation conditions is the greatest and most common cause of accidents.

4.2.4 Mounting conditions for a free-standing mast

The layout shown below indicates the maximum height of a free-standing mast, which may be installed depending on the type of mounting component used on the underlying foundation base. In particular, the following type of installation can be pointed out:

- installation 1, the machine rests on the foundations, with no mechanical mounting components

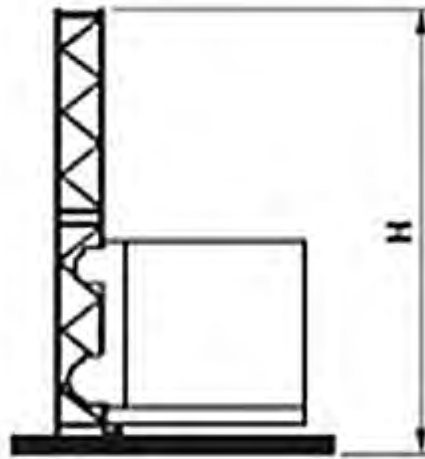

Installation 1

Figure 4.3

	Installation 1
Height H of MC2000PMB V	9.84 ft

DANGER:

It is strictly forbidden to use the machine with the free-standing mast measurements exceeding those specified in the table above.

4.2.5 Condition for anchoring the mast for standard loading unit

The layout shown below indicates the maximum distance there must be between the wall anchors, for the machine's vertical mast to be set correctly.

In particular, the following types of anchor systems can be pointed out:

- Figure 4.3, the first wall anchor is set at 9.84 ft from the base and is a temporary wall anchor to be removed after other wall anchors are installed, the next wall anchor is set 19.68 ft from the base and is the first of the permanent wall anchors, the subsequent anchors after this wall anchor are spaced at a maximum interval of 19.68 ft. The topmost part of the mast after the last anchor cannot and must not exceed 9.84 ft.

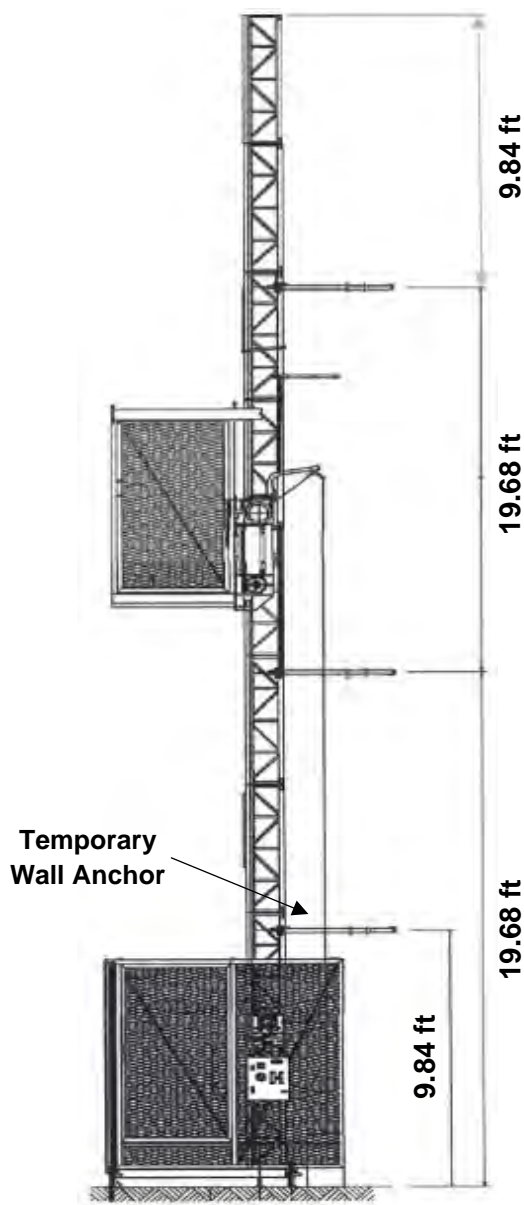

DANGER:

It is strictly forbidden to use the machine with distances between the anchors exceeding those illustrated. It is also forbidden to use the machine with the topmost part of the mast after the last anchor, exceeding the measurement illustrated.

Figure 4.4

4.2.6 Forces onto the wall anchor system

Every anchor extension bar has an anchor point which is fixed to the wall with two mounting components, consisting of wall dowels.

Every anchor point must be able to withstand a maximal pull-out force due to the stress applied by N_A and N_B , acting perpendicular to the wall, and the stress applied by T_A and T_B , acting parallel to the wall.

The forces in question are mainly due to very windy conditions when not in operation, and when the fully loaded platform is in motion or positioned close to the anchor system. Clearly, the building structure onto which the anchor system is applied must be able to withstand the above-mentioned forces. We recommend you use only toggle bolts that are suitable for the type of walling to be used to set each anchor extension bar.

If the machine is anchored to traditional scaffolding or some other type of scaffolding, the joints as well as the entire structure must be properly assessed.

If the anchor system is assembled according to the standard measurements, the values of the forces exerted by the machine onto the wall are shown in the following table:

FORCES EXERTED ON THE STANDARD ANCHOR SYSTEM					DOWEL LOADS	
	N_A (daN)	T_A (daN)	N_B (daN)	T_B (daN)	N_{AV} (daN)	T_{BV} (daN)
MC2500TPM-MV	1250	850	1250	290	1250	900

Tie Dimensions: $X_{max} = 55''$ $X_{min} = 49''$ $Y_{max} = 47''$

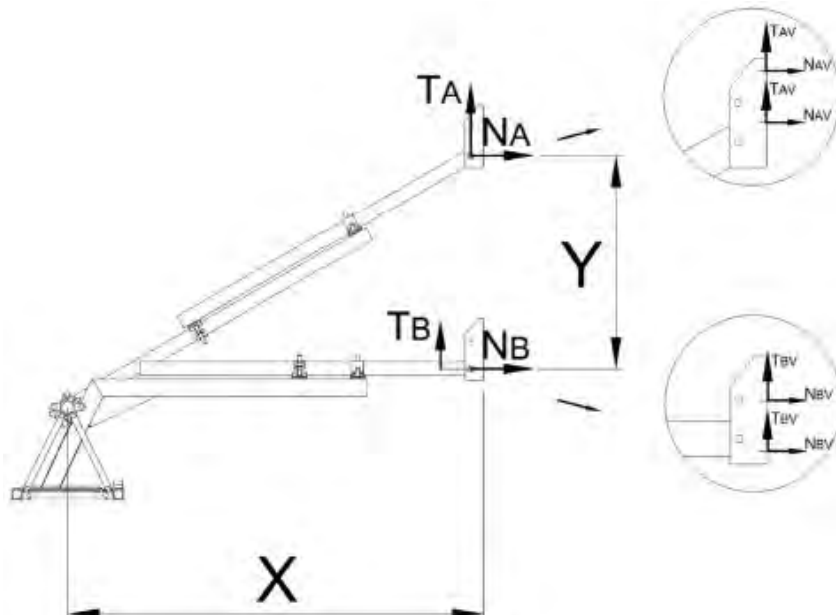

Figure 4.5

Non-standard specifications must be used for the wall assembly if the length of the anchor extensions and the distance between the wall anchors exceed the measurements indicated in the table on the previous page or an alternative wall anchor system needs to be used.

FORCES EXERTED ON THE OPTION A1 ANCHOR SYSTEM				
	d_1 from - to	d_2 from - to	N (daN)	T (daN)
MC2000PMB V	49.2 – 55.12 in	49.2 – 55.12 in	1200	850

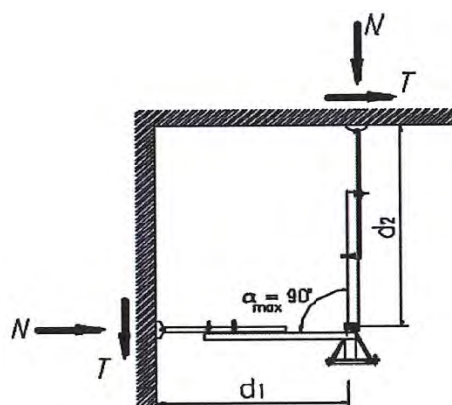

Figure 4.6

FORCES EXERTED ON THE OPTION A2 ANCHOR SYSTEM				
	d_3	d_4	N (daN)	T (daN)
MC2000PMB V	49.2 in	31.5 in <td>1200</td> <td>850</td>	1200	850

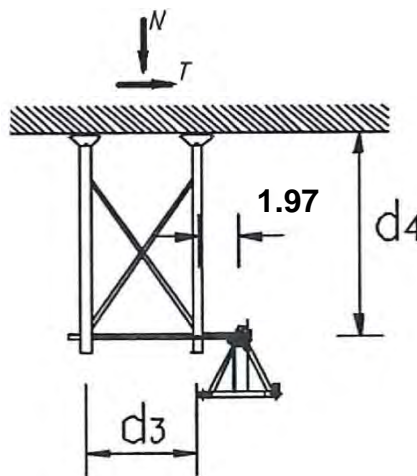

Figure 4.7

FORCES EXERTED ON THE STANDARD ANCHOR SYSTEM					DOWEL LOADS	
	N_A (daN)	T_A (daN)	N_B (daN)	T_B (daN)	N_{AV} (daN)	T_{BV} (daN)
MC2500TPM-MV	1520	1240	1520	340	1250	950

Tie Dimensions: $X_{max} = 98''$ $Y_{max} = 71''$

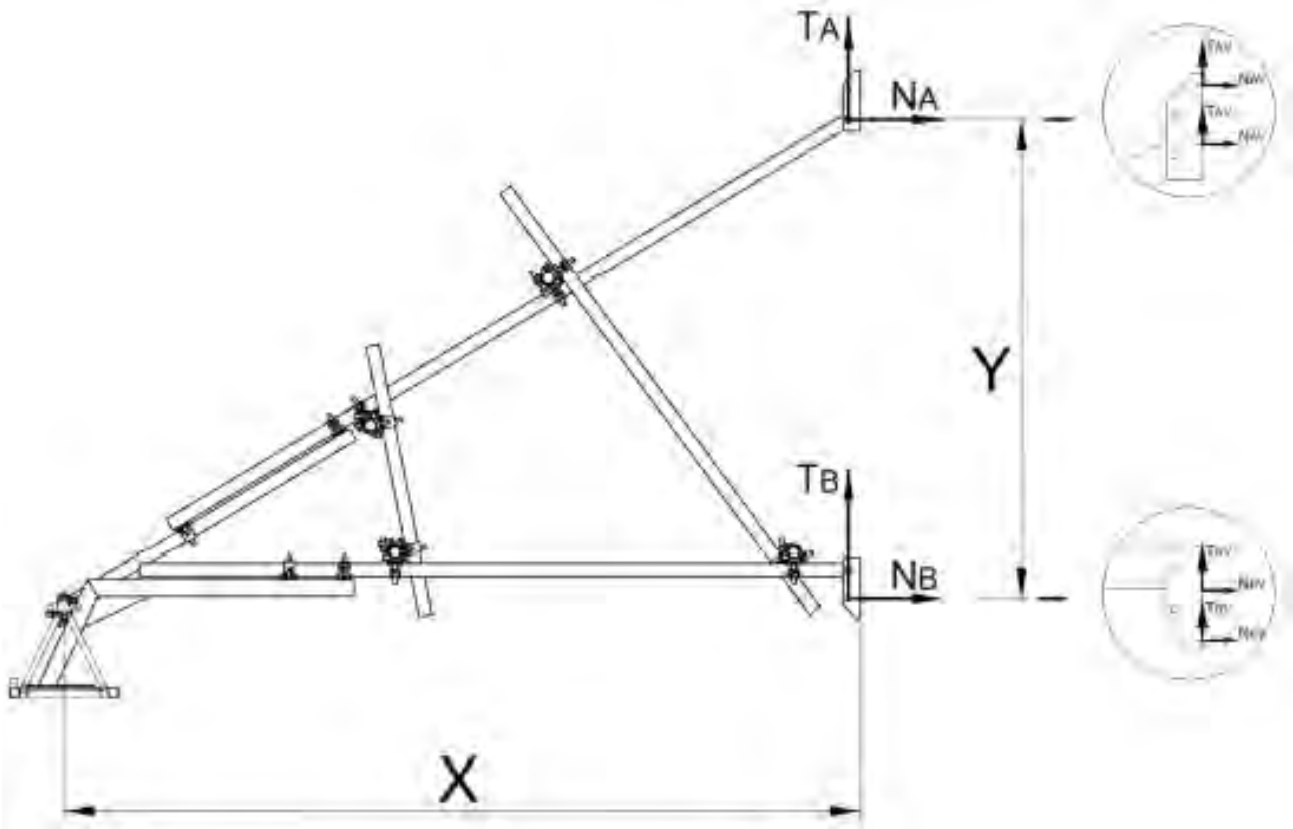

Figure 4.8

4.2.7 Type of anchor system

The area of the building that is normally considered the most suitable for the anchor system to be implemented is the string course slab, where the floor is generally made of reinforced concrete and allows you to implement an anchor system which is solid and secure, with the use of toggle bolts that are suitable for the machine.

Solely for illustration purposes, we can say that by implementing an anchor system on reinforced concrete and using appropriate 1/2" steel dowels (2 for every extension bar), the pull-out forces are remarkably superior to maximal responses of anchor systems.

However, there are other possible solutions for particular cases, such as:

- the kind of wall of the building, or structures with various conformations (windows, obelisk shaped terraces), which are unable to withstand the above-mentioned forces exerted onto the anchor system
- the work that is to be implemented onto the structure, such as facade improvement using insulating panels, or glass paneling

In exceptional cases, if the building has constructive constraints, in order to remedy the situation, it is possible to implement the loop anchor system directly onto the windows or with the use of metal poles inside the building itself, which link the anchor system; all this allows work with such constraints to be carried out, which would otherwise be impossible.

In cases where particular anchor systems must be implemented, such as only one dowel can be used for every anchor extension or if very long extension bars must be used, it is necessary to use larger dowels and more than one rigidity beam in order to secure the anchor system and make it as safe as possible and in keeping with the normal operating conditions.

Please contact and provide the details to BETA MAX Technical Support to determine whether an on-site visit is necessary in order to be given advice or any authorization.

However, BETA MAX disclaims all responsibility for causes due to the implementation of particular anchor systems which are not defined nor authorized beforehand by the company itself and also disclaims all responsibility for anchor systems which are not implemented up to standard even if specifically allowed by the builder; this makes it an obligation to contact BETA MAX Technical Support every time a particular installation is necessary.

IMPORTANT!!! The operator has the explicit task of supervising and giving adequate instructions on good practice by providing safety procedures for the implementation of such work, ensuring that individual protection gear is used and that the work is carried out in authorized places, supervising the quality of work, for example, ensuring that drills with adequate diameters are used, the holes are of the right depth, that bolts and clamps are tightened in accordance with established torque values, etc.

4.2.8 Working conditions with a free-standing mast (not anchored)

The machine is in accordance with the conditions outlined below, can work in free standing mast (not anchored). In this working condition, there is only one possible configuration of installation: with standard base frame in simple support on the ground. Refer to the section “Mounting conditions for a free-standing mast” to get the necessary instructions for maximum free height. For the installation condition that involves the base being anchored carefully read the section “Foundation for the positioning of the machine” for the necessary instructions. Be sure to check which class of wind fits the installation area and in case of doubt keep to the values most limiting.

4.2.9 Information for the commissioning of the mast

The mast sections may present a slight deviation with respect to the theoretical form, in particular way, some slight rotation may result in respect to the vertical axis. Such deviations can't be eliminated as they depend on multiple conditions that may verify during the production stage of the mast sections. The mast section's rotation doesn't mean that the product is defective but it's a normal result of the manufacturing process of such a particular item. In case the mast rotation may cause a sensible rotation of the machine it's necessary to correct the position of the mast sections by the use of the anchorage system.

The correction of the rotation of the mast must be performed on each anchor at the moment of its installation. A correction performed after two or three anchors brings the mast to have an overall rotation too large and difficult or impossible to fix. In these cases, the correction could be made only with the application of very large forces.

To measure efficiently and simply the mast rotation direction, we advise to measure the distance between the external body of the cabin and the wall as indicated at the points **A** and **B** of the figure.

One way to correct the mast rotation is by the use of the anchorage is to adjust the lengths of the anchorage tubes once fixed to the structure (it depends on the direction of the rotation fixing) and to use the tension to circle the mast as indicated by the arrows in the figure.

ATTENTION:

In order to correct the mast rotation, it's possible to use external screw coupling. In this case, pay the maximum attention not to apply extra strength that may deform, permanently the anchorage pipes and not to damage the support structure of the machine.

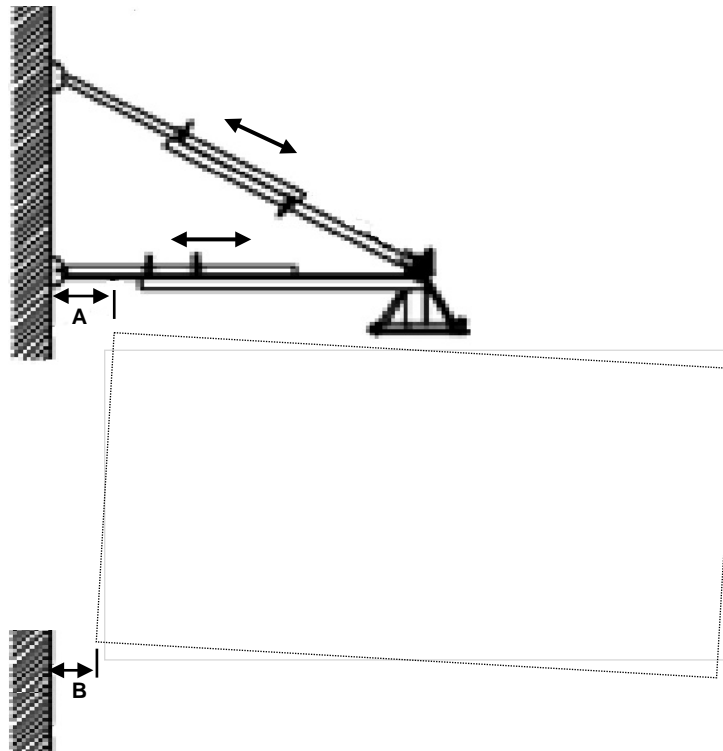

Figure 4.9

4.3 INSTALLATION OF WALL-TIE ON THE MAST

The wall-tie must be installed in the mast by fitting it as shown in Figure 4.9.

<p>ATTENTION</p> <p>The correct locking of the tie clamp requires a tightening torque of:</p> <p>180Nm (133 ft-lbs)</p>	
---	--

To install the parallel tie, hand tighten attachment bolt “A”, open clamp “B” and rotate tie into the position shown below. Close clamp “B” around the round tubing of the vertical mast. Once the tie is affixed to the structure, run bolt “A” out to create a wedge. Use the accompanying nut to lock it into place. Tighten clamp “B.”

To install the diagonal tie, open clamp “C” and affix to the round tubing of the vertical mast either just above, or below the attachment point for the parallel tie. Once the diagonal tie is affixed to the structure tighten clamp “C.”

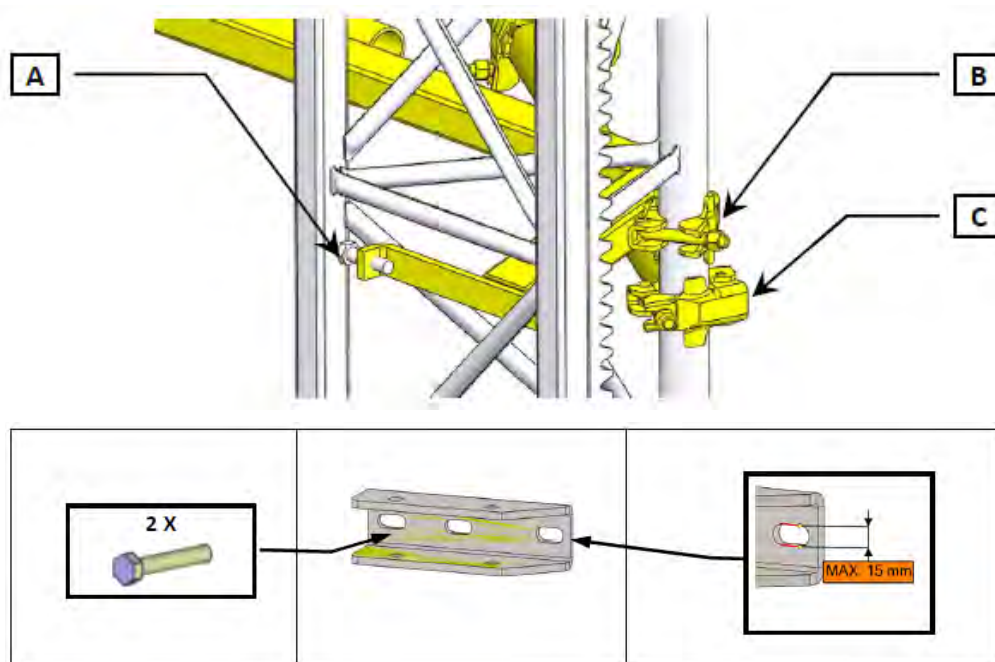

Figure 4.10

CHAPTER 5: HANDLING AND TRANSPORTATION

Record of modifications

Revision	Executor	Date	Description of modification

5 HANDLING AND TRANSPORTATION

5.1 INTRODUCTION AND PRELIMINARY OPERATIONS

The area to be used for preparation of the material, loading, unloading, temporary storage or ware- housing must have clear signs and closed off, in such a way so as to prevent access to outsiders or anyone not authorized.

ATTENTION:

The operations of preparing, packaging, transporting, handling, loading and unloading the machine, must be carried out by personnel who are experienced and/or properly trained.

The preparation, packaging, handling, loading and unloading the machine must be carried out by personnel who is trained appropriately and effectively and directly monitored by the site manager (SUPERVISOR) who has to ensure that the above-mentioned operations are carried out up to standard, in compliance with all the safety conditions whilst meticulously adhering to the instructions found within this instruction manual.

DANGER:

An approximate assessment of the installation conditions is the greatest and most common cause of accidents, often with a fatal outcome.

All the components constituting the machine must be meticulously checked and examined before making them available for a new installation, in order to remove any parts which may be broken, deformed, cracked, corroded or affected by other factors, and no longer ensure sufficient reliability. Once the load is set in place, one must absolutely ensure its stability, and this must be done with a sufficient quantity of belts, ropes etc. arranged in the most appropriate ways and of adequate sturdiness in order to block the load in question.

ATTENTION:

The members of staff, qualified and trained in carrying out the operations of preparing, packaging, transporting, handling, loading and unloading the machine, must be equipped with suitable equipment, according to the particular risks they may be exposed to and individual protection gear such as, work gloves, hard hat, safety footwear with non-slip soles and reinforced metal as well as a toe-cap, safety harness with shoulder straps having hook components, and a high visibility jacket.

5.2 TRANSPORTATION

The packaging of the modular components constituting the machine is designed primarily to reduce clutter, as much as possible. It consists of particular packaging because the various galvanized metal components are tied together in various ways with galvanized mild steel wire but are not placed inside particular containers. This particular type of packaging greatly facilitates the process of unloading the material; it is obligatory to use a crane or a lift forklift to unload the material, due to the weight as well as for reasons of safety of personnel; moreover, in this way, the material is handled with care when in movement and damage is avoided.

The various small components are placed inside proper packaging, inside appropriate cardboard boxes and these are grouped together with all the machine's accessories.

Both electric control panels are placed onboard the machine and therefore do not require particular attention, apart from the necessary precautions when handling and transporting the machine.

Normally, the same types of components are packed together; the machine components are loaded as follows:

- the first components to be loaded are all the packages of the masts, previously packed together in groups of seven or nine units (depending on the measurement of the loading unit of the transport vehicle). In order to increase and guarantee greater compactness and stability of the load, the various packages are tied together with galvanized mild steel wire
- the machine base unit, which consists of all the components constituting the actual machine, is loaded immediately behind the mast components
- once the machine base unit is positioned in place, the accessories put together are inserted where possible (clamps, wall anchor extensions, floor fixing brackets for the anchor system, set of wrenches furnished with the machine, braking pads, etc.) and when possible, packed inside appropriate cardboard boxes, which can be moved by means of a lift truck in order to facilitate and speed up the processes of loading and unloading in the construction site. This method allows the load to be distributed as uniformly as possible onto the transport vehicle, obtaining a center of gravity position on the vehicle's center line, and placed as close as possible to the axle of the driving wheels

5.3 HANDLING

Transportation of the machine must be carried out in compliance with the Highway Code that is in force in the locality where it must be carried out, even if the distance covered is short, from one construction site to another. With regards to transportation for the first installation, BETA MAX uses a tested positioning system, to place the various components of the machine onto the various transport vehicles. This allows the warehousing department to establish the exact overall dimensions and therefore, the capacity that the transport vehicle is required to have for any type of arrangement of hoist which is to be dispatched. This positioning system is valid for the classic type of transportation by truck as well as for transportation by container. The handling procedure described below can be considered as a general rule, applicable for every trip the machine will make during its operational life.

The general criteria to be followed, in order to avoid any damage when handling the machine when transporting it from one construction site to another, mainly concerns the maneuvers when loading and unloading, which are critical stages during which considerable damage can be done. Consequently, the members of staff who are responsible for these operations must:

- use lift trucks as shown in figure 5.1 or cranes as shown in figure 5.2, when handling the material. The crane used can be the one forming part of the transportation vehicle itself or any other used in the construction site. It is absolutely necessary for the lifting equipment to have adequate strength to lift the load
- always ensure that the material to be lifted, which may consist of a packed group of components or a single component, does not accidentally hook onto other components of the machine, dragging them high up

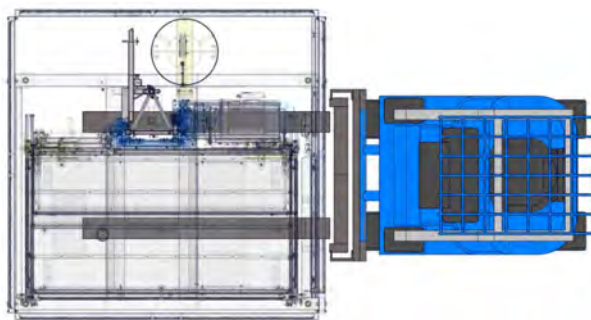

Figure 5.2



Figure 5.1

- if the package that is being lifted consists of the same type of components and these are joined together, ensure that the binding tie, which usually consists of a tie made with galvanized mild steel wire, is intact and adequately strong enough

- not applying any means to the components of the machine, in any way, to facilitate the lifting process, such as metal eye bolts, which could cause structural damage to various components of the machine
- use flexible belts, which are allowed, arranging them in a suitable layout for the component to be strapped correctly when lifted, in accordance with the load capacity that the belt itself can sustain
- avoid, in every way, knocking the load against any other components of the machine or against the ground
- ensure that when the material is made to rest on the ground, it can maintain its stability

When the machine is lifted, you must avoid it from jerking or swinging abruptly, and you must also pay utmost attention when resting it on the ground, which must be done in such a way so as not to damage the leveling bolts (if presents).

DANGER:

It is absolutely forbidden to stay in the operating area of the lifter while the machine's components are lifted and moved.

ATTENTION:

During the loading/unloading stage, which will be described further on, or any other stages of work that involve lifting material, for no reason whatsoever should anyone pass or stay under the suspended load.

5.3.1 Fork Trucks

The use of lift trucks as shown in Figure 5.1, when handling the material, it is absolutely necessary for the lifting equipment to have adequate strength to lift the load.

To lift the machine by forklift, insert the two forks into the two dedicated points under the base of the machine. Lift the machine very slowly and for a max of 6" from the surface.

ATTENTION:

Before lifting the machine, ensure the loading unit is lowered completely onto the base.

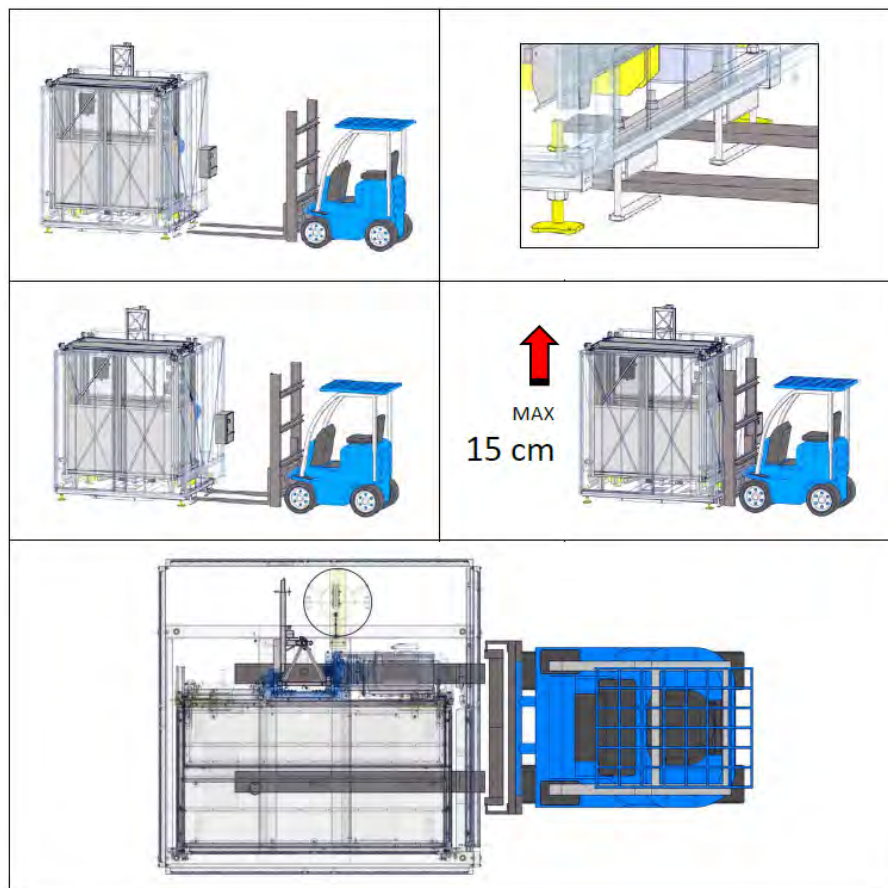

Figure 5.3

5.3.2 Lifting eye

The use of the lifting eye, as shown in Figure 5.4, when handling the material always ensure that the material to be lifted, which may consist of a packed group of components or a single component, does not accidentally hook onto other components of the machine, dragging them high up.

ATTENTION:

THE MACHINE MUST BE LIFTED ONLY WITH AN EMPTY CAGE AND WITHOUT THE CABLE DRUM!

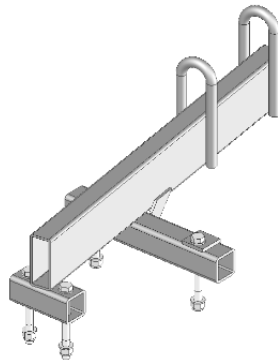

Figure 5.4

Attache the lifting eye to the unit using (4) M18x170 (class 8.8) bolts with dedicated self-locking nuts M18 and washers as shown below.

ATTENTION!

Hardware must be tightened to 180 Nm or 133 ft-lbs.

Ensure the loading unit is empty of any items stored for transport and install a single mast section onto the mast attached to the base *figure 5.5*.



Figure 5.5

Position the lifting eye onto the top of the 2nd mast section with the cantilever facing towards the center of the loading unit. Attach the lifting eye figure 5.6 with the hardware listed below and tighten to 180 Nm (133 ft-lbs).

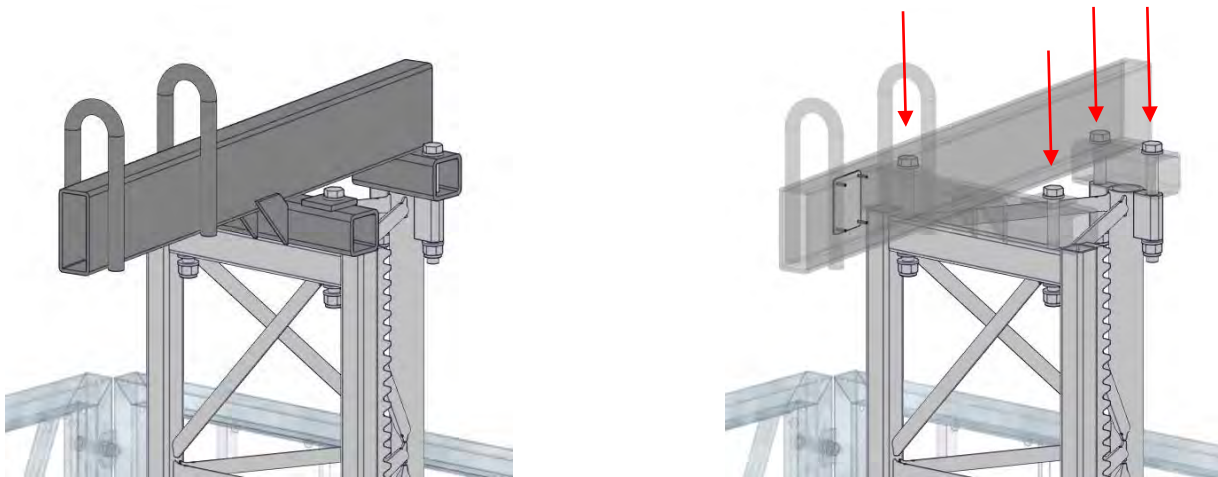

Figure 5.6

- 4 Bolts M16 x 160mm Class 8.8
- 8 Washers for M16
- 4 Self-locking nuts M16

Use the appropriate lifting means according to the capacity to lift the unit as shown in *figure 5.7* below. If the unit is not balanced in the horizontal position, try the other attachment point on the lifting eye.

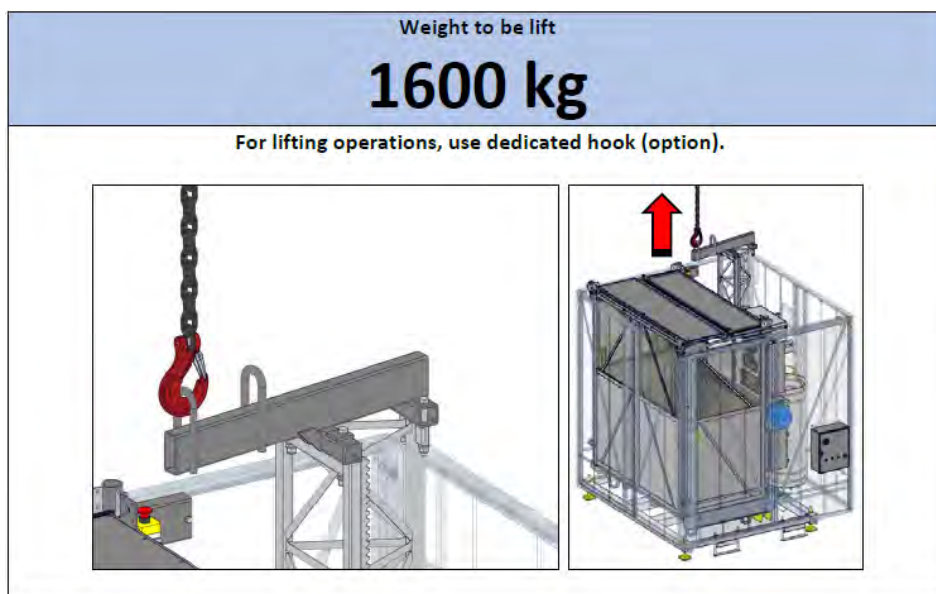

Figure 5.7

5.4 LOADING AND UNLOADING

In order to optimize all subsequent stages of work, before proceeding to load or unload the machine, carry out the operations described below:

- close off the area where operations of loading and unloading the machine are carried out, in a clear and unequivocal manner, and enclose its perimeter in an effective manner, to prevent possible access to outsiders or persons anyhow not authorized. Bear in mind that the subsequent operations will be implemented at a substantial height from the ground, and should any component or equipment accidentally fall, it can result in immediate and serious danger
- ensure that the floor on which the equipment constituting the machine is to be placed is horizontal and sufficiently stable, so not to cause dangerous situations of the equipment tipping over, collapsing or subsiding
- unload the machine from the transport vehicle using a crane or lift truck which has an appropriate lifting system. If using a lift truck, the lifting attachments can be placed on the lower part of the base unit. If using a crane, strap the machine from the base unit with belts which have an adequate load capacity. In both cases the machine must be perfectly balanced
- for no reason whatsoever, should anyone pass or stay under suspended loads during this stage and the other stages, which will be described further on, of un/loading. If using a crane, only the operator will be authorized to handle the suspended load in order to facilitate its correct positioning when it reaches a height of 8 in. from the ground. If using a lift truck only the driver of the same truck will be authorized to carry out the operations; all other persons will have to stay at a distance where they cannot be affected in case of the load accidentally tipping over and they have to remain there until the operation is carried out completely. It is absolutely necessary for individual protection gear to be worn during these operations
- unload the remaining material and accessories constituting the machine and distribute them in an orderly and safe manner within the closed off area. Ensure that the material placed on the ground cannot, in any way, accidentally move, constitutes a danger to persons working nearby or subsequently interfere when moving the machine
- if part of the material has been placed in the free spaces inside the machine, or components have been placed in rows lying on top of each other (to optimize space allocation), remove the material from this layout and place it on the ground before carrying out any other handling operation

DANGER:

Close off the area where operations of loading and unloading the machine are carried out, in a clear and unequivocal manner and prevent possible access to outsiders or persons anyhow not authorized to enter this area. Should any components or equipment accidentally fall from a substantial height when loading or unloading, this can result in immediate and serious danger.

CHAPTER 6: INSTALLATION

Record of modifications

Revision	Executor	Date	Description of modification

6 INSTALLATION

6.1 INTRODUCTION

The operations described in this chapter are of particular importance as they explain the installation and disassembly procedures of the machine. Experience has shown that accidents (fortunately rare) have never occurred during normal operation, but have always occurred during the installation process, and even more during the disassembly process of the machine. During these operations there are utensils and equipment, material and components of the machine which have not yet been permanently fixed, and they simply rest on the horizontal level of the working area and the machine itself can seem to be stable even though it is not yet completely and definitely mounted and anchored to the structure in question.

ATTENTION:

Before starting to implement the operations mentioned below, the persons who are designated to perform the work must have read and more importantly UNDERSTOOD the instructions in this manual.

The operations of: loading/unloading, handling, transporting, assembling, using and disassembling the machine must be carried out by personnel who is trained appropriately and effectively and directly monitored by the site manager (SUPERVISOR) who has to ensure that the above mentioned operations are carried out up to standard, in compliance with all the safety conditions and meticulously adhering to the instructions found within this instruction manual.

DANGER:

An approximate assessment of the installation conditions is the greatest and most common cause of accidents, often with a fatal outcome.

ATTENTION:

During the installation process, the use of the machine must be absolutely forbidden to all unauthorized personnel and must remain the exclusive responsibility of the person designated to carry out this process.

All the components constituting the machine must be meticulously checked and examined before every new installation, in order to remove and unequivocally mark any parts which may be broken, deformed, cracked, corroded or affected by other factors, and no longer ensure sufficient reliability. The members of staff, qualified and trained in carrying out the operations of assembling, checking, handling, using and disassembling the machine, must use suitable equipment, according to the particular risks they may be exposed to and individual protection gear such as, work gloves, hard hat, safety footwear with non-slip soles and reinforced metal as well as a toe-cap, safety harness with shoulder straps having hook components, and high visibility jacket, etc.

- The following functions have to be constantly monitored during the assembly operations:
- the exact positioning of the structures and components constituting the machine, in accordance with the heights and indications shown in the installation design, and particularly in conformity with the horizontal and vertical measurements or distances provided in the design itself
 - proper implementation of the machine's anchor devices, in conformity with the executive layouts and particular instructions provided by the manufacturer
 - functionality and efficiency of the mechanical, electromechanical and electrical safety devices, specifically intended for assembly, use and disassembly of the machine.

ATTENTION:

Always ensure that during the installation process the wind speed does not exceed 28 MPH.

ATTENTION:

Meticulously adhere to the configurations and layouts provided and permitted in this instruction manual. Layouts and configurations which are different from those provided are exclusively allowed if specific authorization is given by the BETA MAX technical office. BETA MAX disclaims all responsibility for non-compliance or all the more for contributory negligence in respect to the restrictions given.

6.2 INSTALLATION DATA SHEET

The data sheet contains the weight of the machine and the heights relative to the installation of the machine in question.

The data sheet must be completed by the site manager.

The data sheet duly photocopied and signed must be handed over to the operator designated to carry out the machine's assembly. This document is to be the reference document for the installation process. See appendix A in this manual.

DANGER:

Non-conformity with the indications given in the assembly data sheet can damage the machine and endanger the operators responsible for its use. BETA MAX disclaims all responsibility deriving from non-compliance with that which is specified in the assembly data sheet.

6.3 INSTALLATION PROCEDURE

This paragraph is intended to guide the operator during the machine installation, indicating the different execution phases order with relative detailed paragraphs described for each operation. In order to do a correct installation, proceed as follows:

1. check and verify all of the machine's components
2. prepare the machine's installation site
3. position the machine at the site
4. prepare all the electric power connections of the machine
5. rotate the machine mode key switch onboard control panel to the "ERECTION" position to enable the machine functioning through the loading unit directly
6. rotate the control mode key switch onboard control panel to the "CABIN ONLY" position to enable the machine functioning through the loading unit ONLY
7. install the mast, anchorages and accessories
8. install the braking pads
9. install the floor's access doors
10. install the stop cams on the mast by adjusting their position in order to allow the stop at the ground
11. program the floor landing levels and door unlocking settings
12. attach the calling board from the floors beginning from the base control panel

6.3.1 Machine configuration

The MC2000PMB-V can be installed in one of two possible configurations shown below in Figure 6.1. The STANDARD configuration (most common) is one where the exit ramp and wall-ties are installed on the left side of the machine (erector's platform side). The REVERSE configuration is one where the exit ramp and wall-ties are installed on the right side of the machine (motor side).

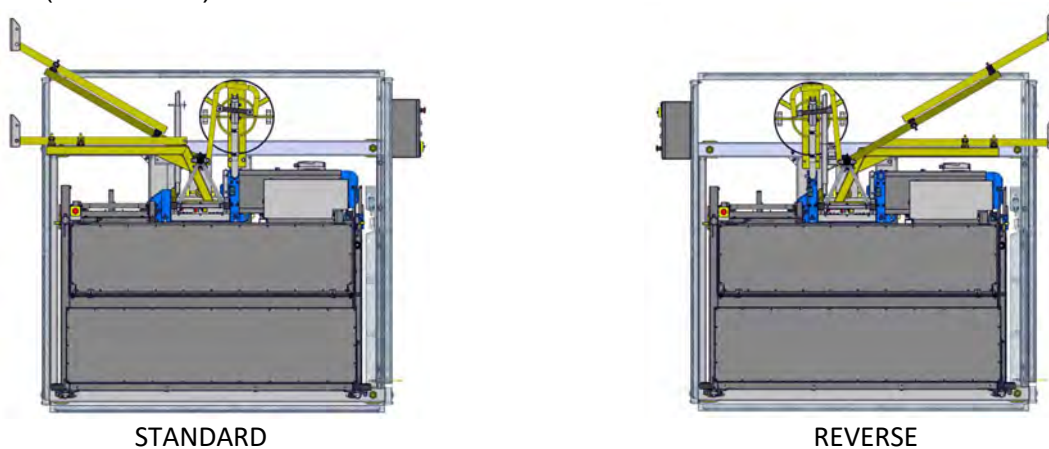

Figure 6.1

6.3.2 Machine configured in the STANDARD configuration

Generally, the machine is assembled in the “STANDARD” configuration, which means:

- Unloading ramp (A) is on the left side of the machine (erector’s platform side)
- Loading ramp (B) is on the right side of the machine (motor side)
- The cable gooseneck (C) is installed on the right side of the machine (motor side)
- The cable drum (D) is installed on the right side of the machine (motor side)
- The wall ties (E) will be installed on the left side of the machine (erector’s platform side)

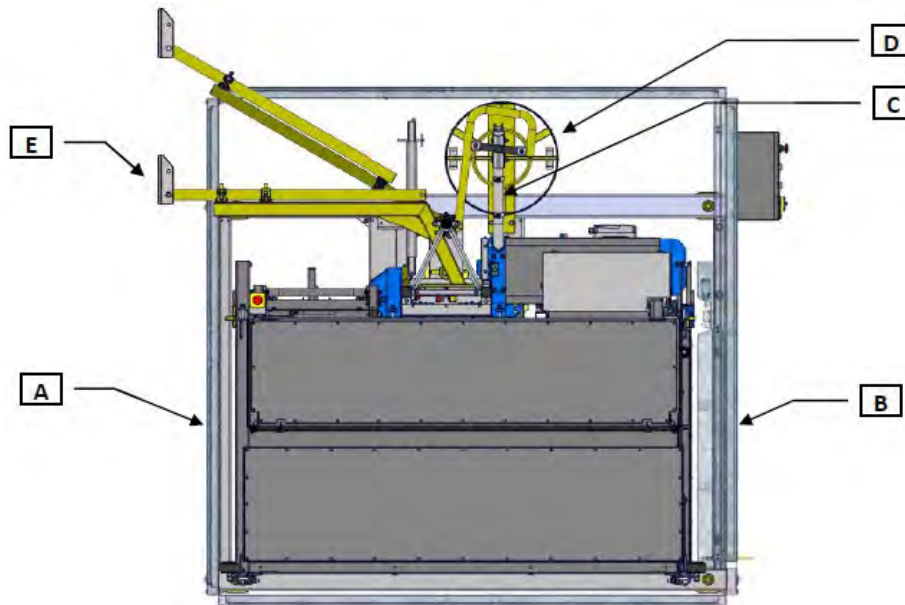

Figure 6.2

6.3.3 Converting the machine to the REVERSE configuration

The loading unit of the machine can be configured with a different type, position, and number of ramps. This adaptability allows for the unit to be utilized in various job-site environments to ensure proper loading and unloading of materials and/or persons. Below is the procedure for converting the unit from the STANDARD configuration to the REVERSE configuration.

To convert the machine into the REVERSE configuration, it is necessary to mount:

- Unloading ramp (A) is on the right side of the machine (motor side)
- Loading ramp (B) is on the left side of the machine (erector's platform side)
- The cable gooseneck (C) is installed on the left side of the machine (erector's platform side). Additional, optional component needed
- The cable drum (D) is installed on the left side of the machine (erector's platform side)
- The wall ties (E) will be installed on the right side of the machine (motor side)

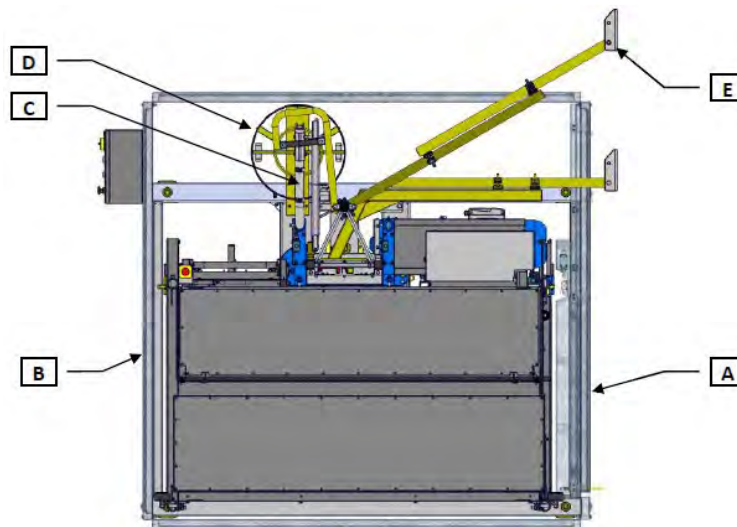
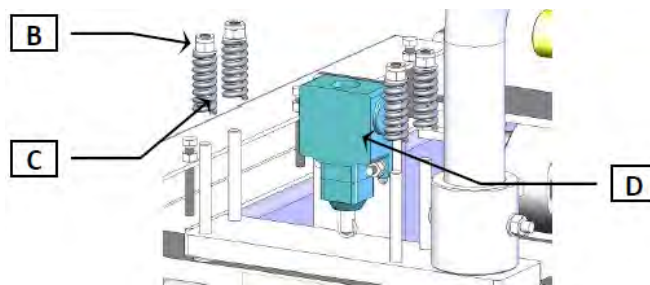

Figure 6.3

6.3.3.1 Relocating the cable gooseneck

The trailing cable gooseneck must be relocated to the opposite side of the mast to avoid striking the wall tie assembly when installed in the REVERSE configuration. To perform this function the optional cable gooseneck stirrup is needed (p/n 10-439).

1. Remove the (4) self-locking nuts (B) and (4) springs (C). Remove the monitoring electrical limit switch holder (D). Retain these items for use later.



2. Mount the gooseneck stirrup (p/n 10-439) (E) in the shoulder on the lifting unit as shown. Use the following supplied hardware:

- (2) Bolts M12x40mm
- (4) Washers M12
- (2) Self-locking nuts M12

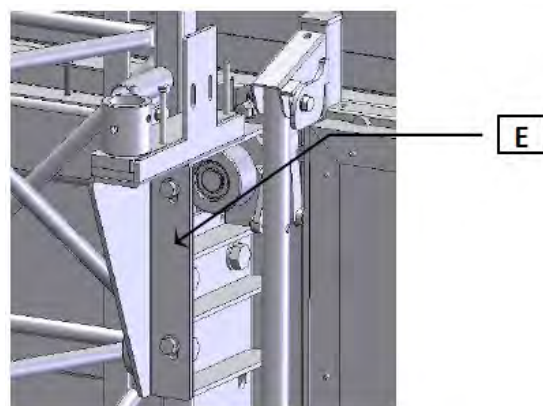

3. Install the springs (H), washers and nuts (F) and limit switch (D) on the mounted gooseneck stirrup.

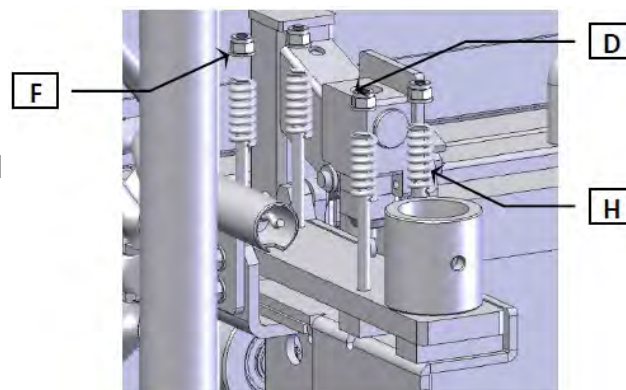

4. The springs must be compressed according to the height of the machine mast to be able to counteract the weight of the trailing cable when the machine is in its uppermost position. Adjustment may be required during the initial test run. The wheel of the limit switch (D) must be adjusted so that the wheel is in contact with the stirrup plate (I).

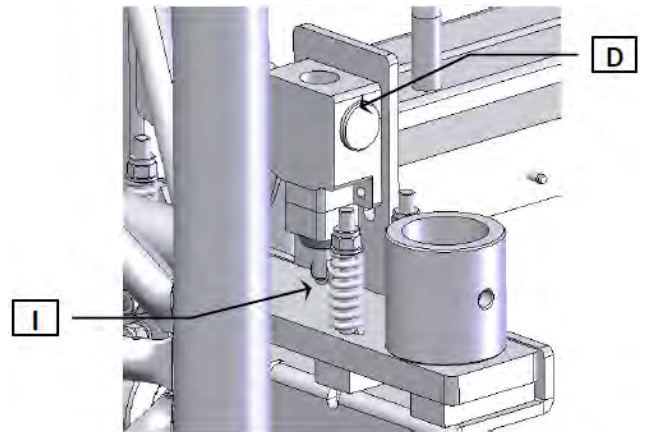

5. Install the gooseneck in the receiver cup and tighten bolts (B) and (C). When installing the trailing cable, route it through bracket (D) and secure it with cable lock (A). Use zip ties if necessary to secure the cable when routing to the control's enclosure.

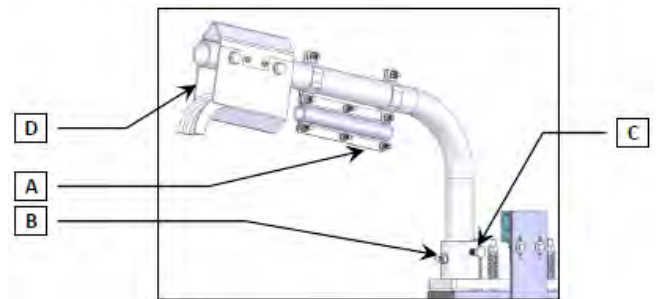

- 6.3.3.2 Relocating the trailing cable drum
 Support the cable drum and remove the hardware by securing it to the base-frame. Relocate to the other side of the vertical mast and reinstall.

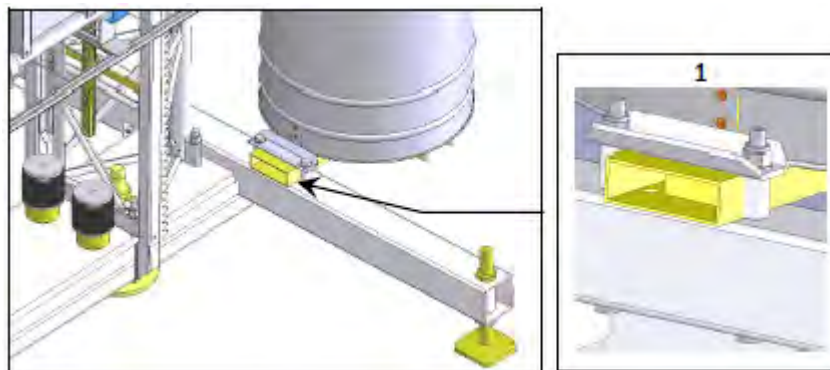

6.4 TEST AND VERIFICATION DATA SHEET OF THE MACHINE'S COMPONENTS

The test data sheet, attached to the machine's use and maintenance instruction manual, is the original, and a double copy of it must be completed by the person who is adequately trained to carry out the installation operations. It is obligatory to state the name and address of the installation technician in this copy. A copy of the above-mentioned data sheet, with all sections completed correctly, must be handed over to the site manager where the machine is to be installed and to the owner of the machine.

The data sheet in question must be completed and signed before an installation process is carried out or, alternatively, every time the machine is returned after being installed in a construction site and therefore, kept as proof after having checked the functionality of the machine. See appendix B in this manual.

NOTE:

Verifying and testing all the material listed in the data sheet will allow the machine to be installed correctly.

6.5 FOUNDATION FOR POSITIONING THE MACHINE

In order to position the machine safely and correctly, a full study of all structural drawings of the building will be strictly needed, with special attention at the foundations where the machine is supposed to be positioned; It will be necessary to exclude any presence of underground drainage, duct or any other cavity that could cause the subsiding of the machine's base frame during its working period. It is extremely important to evaluate the grounds' consistency to ensure that it will withstand the pressure exerted. In case of support feet only would not give enough guaranties of resistance, planking has to be put under each support foot or create special structures to share in satisfactory values the surface pressure. This operation is of fundamental importance because in case of support subsiding it would cause the verticality loosing of the mast and the anchors downwards strain. That condition would be very dangerous for machine stability. The operator is asked to verify the specific aspect and operate in agreement with all safety measures reported in this manual.

Refer to the machine's table of weights to check the actual ground pressure for every installation and adopt the related foundation criteria.

When assembly is carried out with a free-standing mast and the base unit is anchored to the ground, it is fundamental to create an adequate concrete slab or use a metal plate; in both cases, the minimum measurements must be 108 in x 108 in.

The concrete slab must be made in accordance with the following instructions:

- the concrete must be perfectly vibrated
- the finished surface must be perfectly level and smooth
- the foundations can be made in either one of the following ways, depending on the desired level of the finished surface of the concrete slab in respect to the ground

To make the foundation it must be taken into consideration, all exerted loads with the machine fully loaded working and considering the total height of the installation as follows:

HEIGHT (ft)	ACTION TRANSMITTED BY THE CENTRAL JACK TO THE GROUND R.V.C. (daN)	ACTION TRANSMITTED BY EACH SIDE JACK TO THE GROUND R.V.L. (daN)
33	3570	220
66	3865	240
98	4130	255
164	4735	285
328	6160	375
394	6725	410
492	7570	460

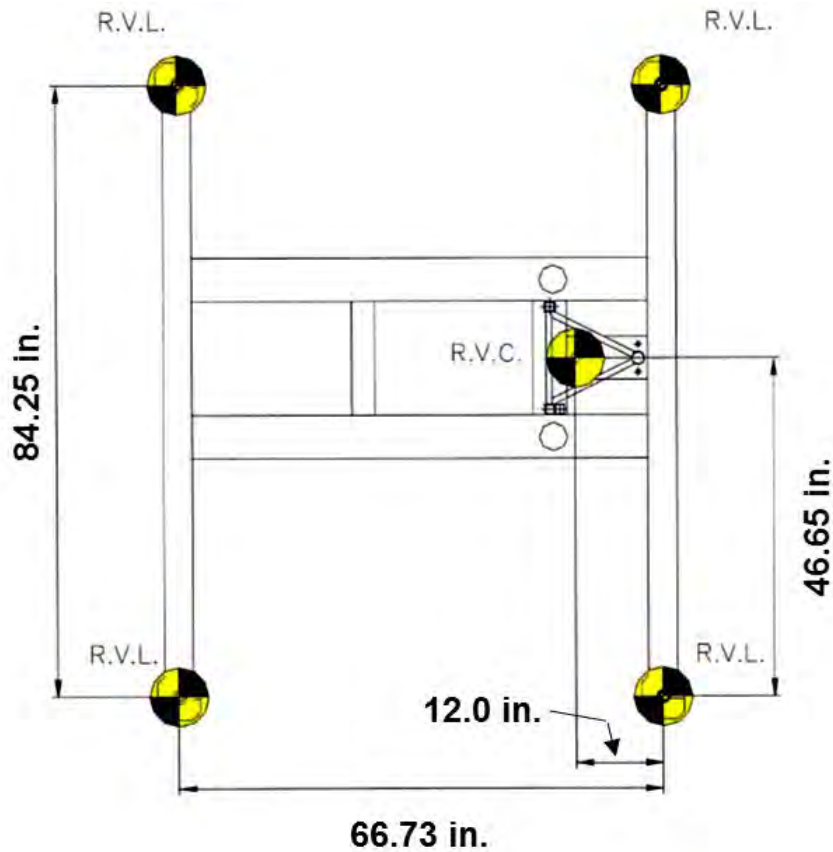

Figure 6.4

6.5.1 Concrete slab resting on the ground

The concrete slab made to rest on the ground has the following advantages and disadvantages:

- advantage: it is not required to be drained
- disadvantage: high threshold

6.5.2 Concrete slab at the same level of the ground

The concrete slab at the same level of the ground has the following advantages and disadvantages:

- advantage: it is not required to be drained
- disadvantage: the loading unit has a high threshold

The concrete slab at the same level of the ground is the most common type of foundation. Normally, a ramp is made in wood or steel, in order to reach the threshold level of the platform.

6.5.3 Concrete slab below ground level

The concrete slab below ground level has the following advantages and disadvantages:

- advantage: no height threshold between the ground level and the loading unit's
- disadvantage: corrosion; if water remains in the foundation and it is not perfectly drained

This alternative requires the ground to be drained carefully. It is very important that the foundation remains insulated from the surrounding ground, otherwise you must prevent the surrounding ground from freezing.

6.5.4 Minimum area for machine placement

The following information details the minimum area required based on machine configuration.

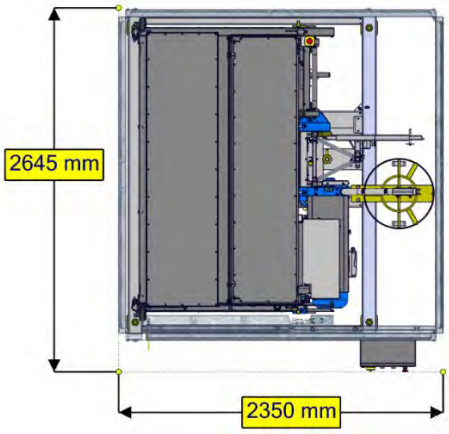
<p>Base enclosure without 2nd entry.</p> <p>Cable drum</p> <p>500mm</p>	
--	--

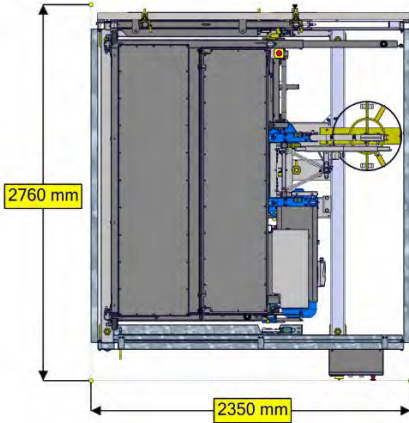
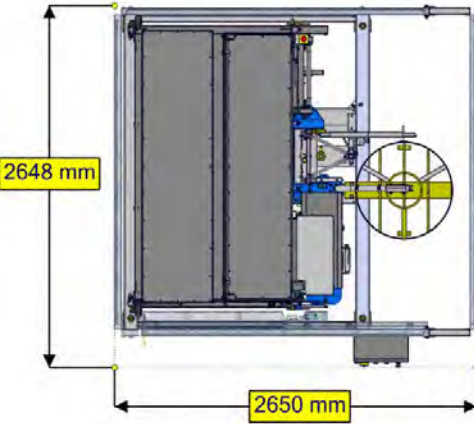
<p>Base enclosure with 2nd entry. Cable drum 500mm</p>	
<p>Base enclosure without 2nd entry. Cable drum 700mm</p>	

6.6 DISTANCE OF THE MACHINE FROM OBSTACLES

When choosing the installation position, it is necessary to check for the presence of any obstacles anywhere near the machine elevation path and measure their minimum distance from the nearest part of the machine itself.

The machine is installed with a clearance between the car platform sill and the hoist way edge of any landing sill shall not be less than 3/4 in. and no more than 2-1/2 in. in accordance with ANSI/ASSE 10.4. The clearance between the edge of the car platform sill and the hoist way enclosure fascia for the full width of the clear hoist way door opening shall be not more than 8 in.

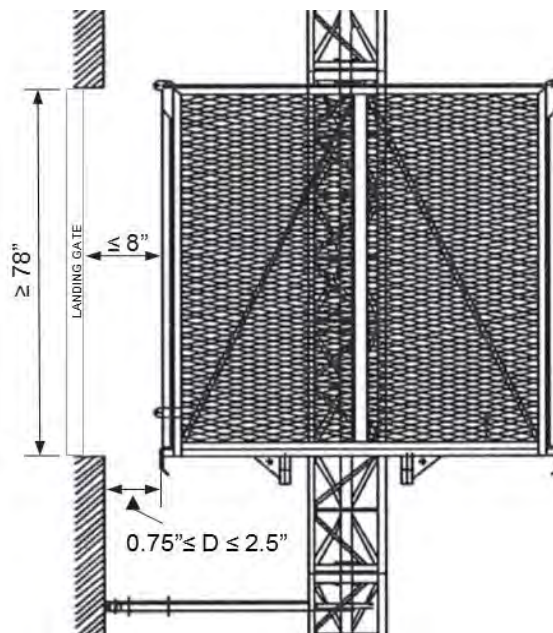

Figure 6.5

6.7 MOUNTING INSTRUCTIONS

The machine must always be used in accordance with standards of operation and safety regulations in force in the country where it is to be used. The following rules are therefore only indicative and must be implemented accordingly to each specific case.

For the assembly and use of the machine, carry out all the operations described below, in succession.

ATTENTION:

All the assembly and disassembly operations of the machine must be carried out solely by personnel who is authorized and trained beforehand on its specific operation and use.

6.8 MOUNTING THE PRE-ASSEMBLED MACHINE

To mount the pre-assembled machine, proceed as described below:

- close off the area where the un/loading and assembly operations of the machine are to be carried out, in a clear and unequivocal manner, and enclose its perimeter in an effective manner, to prevent possible access to outsiders or persons not authorized. Bear in mind that the subsequent operations will be implemented at a substantial height from the ground, and should any component or equipment accidentally fall, it can result in immediate and serious danger
- ensure that the floor on which the machine is to be placed is horizontal and sufficiently stable, in accordance with what is stipulated in the chapter within this use and maintenance instruction manual, pertaining to the description of the foundation to position the machine
- unload the machine from the transport vehicle using a crane or lift truck which has an appropriate lifting system. If using a lift truck, the machine can be placed on the lower part of the base unit. If using a crane, strap the machine from the lifting eye with belts which have an adequate load capacity. In both cases the machine must be perfectly balanced
- for no reason whatsoever should anyone pass or stay under suspended loads during this stage and the other un/loading stages, which will be described further on. If using a crane, only the operator will be authorized to handle the suspended load in order to facilitate its correct positioning when it reaches the appropriate height from the ground. If using a lift truck, only the driver of the same truck will be authorized to carry out the operations; all other persons will have to stay at a distance, where they cannot be affected if the load accidentally tips over and they have to remain there until the operation is carried out completely. It is absolutely necessary for individual protection gear to be worn during these operations
- proceed to unload the remaining material and accessories constituting the machine and distribute them in an orderly and safe manner close to the machine itself. Ensure that the material placed on the ground cannot, in any way, accidentally move, and constitute a danger to persons working nearby and for no reason whatsoever, subsequently interfere with the machine's path
- if part of the material has been placed inside the machine's loading unit (to optimize space allocation, remove the material from the unit and place it on the ground before carrying out any other operation pertaining to the installation
- ensure that no damage has been caused to the equipment during transportation or during the loading/unloading operations

DANGER:

Close off the area where the loading/unloading and assembly operations of the machine are carried out, in a clear manner and prevent access to outsiders or persons anyhow not authorized to enter this area. Should any components or equipment accidentally fall from a substantial height during the assembly process, can result in immediate and serious danger.

6.8.1 Positioning the machine on the ground

To position the machine on the ground, proceed as described below:

- check the condition of the flooring it is to rest on this must be as uniform and level as possible and clear of any obstacle. The machine must be installed in such a way for the base unit to be perfectly level, reducing the overall inclination to an angle smaller than 1°. Check its consistency and suitability for the machine's load and adopt all measures indicated in the chapter called "Foundation for positioning the machine" in this use and maintenance manual
- visually inspect the machine's path which is to be used and ensure that it is free from power lines, telephone lines, or cables of streetlights etc., or any protruding parts or parts with rough edges jutting out of the building or structure in question; moreover, ensure that there are no structures which may be eventually modified and interfere with the machine's path
- place the machine in the exact place where it should be installed, carefully verifying the distance between the loading unit and the part which protrudes the most from the building or structure in question; the loading unit must pass through this distance safely, in its every possible condition
- **this clearance between the car platform sill and the hoist way edge of any landing sill shall not be less than 3/4 in. and no more than 2-1/2 in. in accordance with ANSI/ASSE 10.4 in order to ensure the loading unit passes through with no difficulty and no risk of collision**
- when positioning the machine, you must measure the distance from both extreme ends of the loading unit in respect to the structure in question, in order to be sure that there is parallelism between the machine and the facade. The difference between the measurements taken from the loading unit's extreme ends must not, in any case, exceed 3/8 in. and be between the sill clearances mentioned above

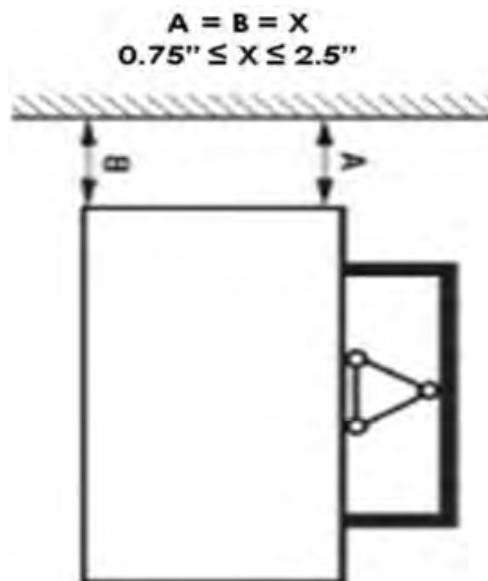
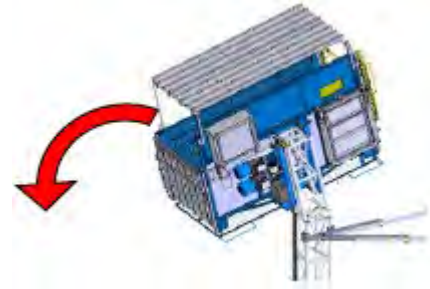

Figure 6.6

Install a mast above the one on the base, after having verified that both support surfaces are perfectly clean and free from any residue; carefully tighten the fastening bolts (refer to the table that indicates the correct tightening torques in respect to the particular bolt). Ensure that the two extreme ends of the masts which come into contact fit perfectly with no ridges between the main vertical supports or between the racks, as shown in figure (no residual air must remain in between the surfaces when they come into contact). If the connection between two masts does not seem to be perfect or does not comply with the instructions provided earlier on, contact BETA MAX Technical Support immediately.

DANGER:

The absence or incorrect fastening of mast hardware will cause the machine to overturn.



NO

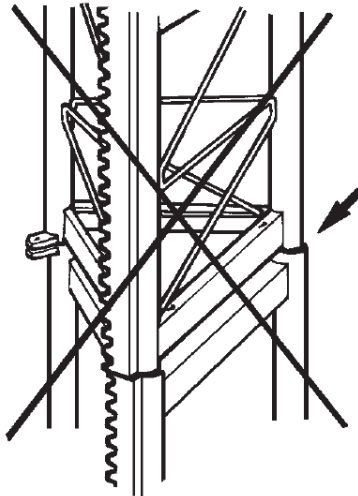

YES

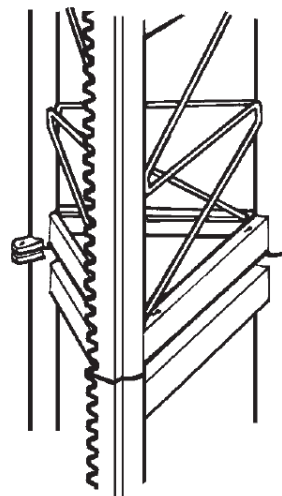

Figure 6.7

- with the use of a spirit level (1), and by using two sides of the rack as a reference plane, check the mast's verticality. Carry out this procedure on the mast as soon as it is installed, bearing in mind that the higher this verification is carried out, the more the leveling will be correct, since the difference generated by the angle of inclination in respect to the ground will be amplified
- in case of incorrect leveling, disposing of a machine without support feet, to correct the eventual errors of installation, operate on the supporting surface so as to ensure the horizontally and the stability of the whole
- in the case of incorrect leveling, disposing of a machine with support feet, operating on the support feet (2) up to reach the condition of verticality

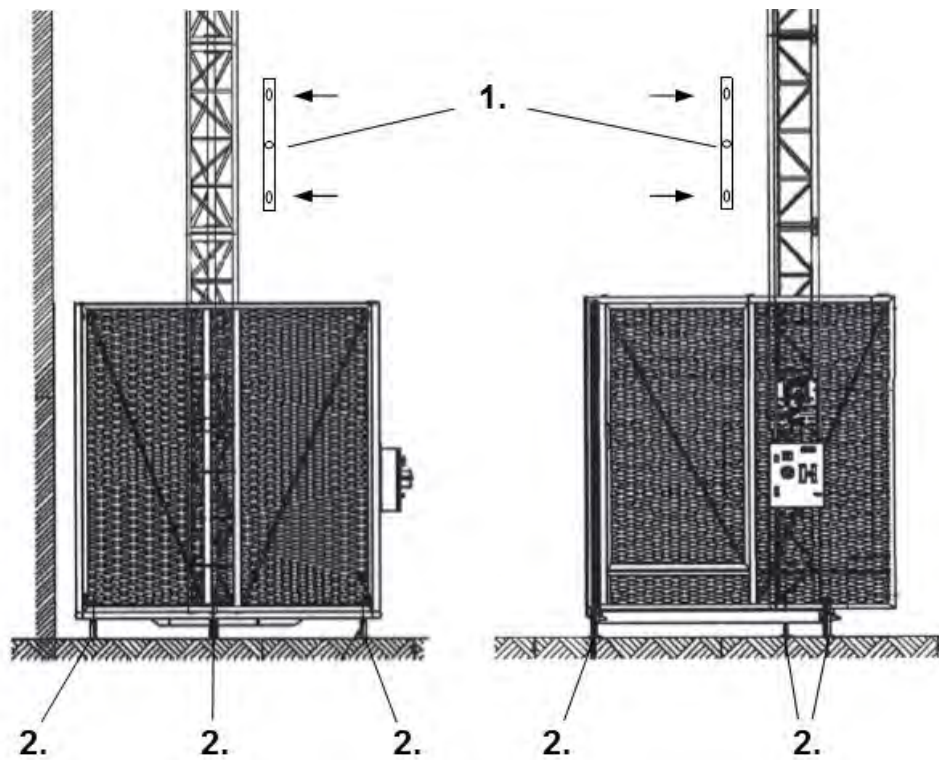

Figure 6.8

6.8.2 Adjustment of base leveling jacks

Once the machine is placed, adjust the 5 base leveling jacks (*figure 6.9*):

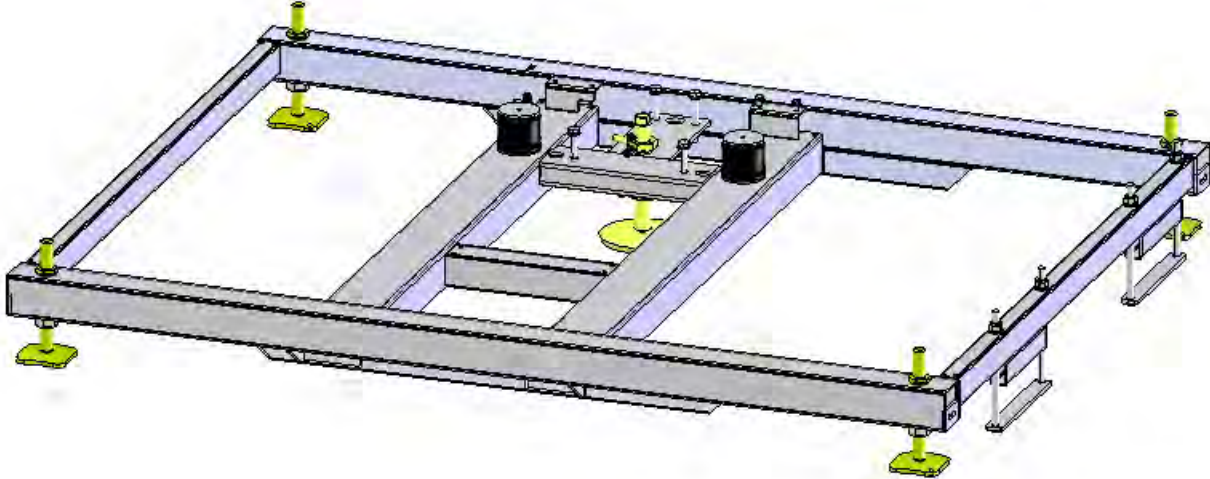

Figure 6.9

- Lift the central jack under the mast all the way up and lock in place.
- Adjust the 4 lateral jacks to align the vertical mast on the 4 sides (check verticality using a spirit level).
- Once level, lower the central jack under the mast till it makes contact with the ground and tighten.

ATTENTION:

Do not apply pressure on the central jack when lowering to the ground. Only lower until contact with the ground is made!

ATTENTION:

The leveling of the mast is a critical process. The mast **must** be positioned in conditions of absolute vertical inclinations. Mast that exceeds 1 degree are not permitted.

ATTENTION:

Mast hardware must be torqued to 180Nm (133 ft-lbs).
Mast hardware consists of the following:

- (4) M16x180mm Class 8.8 Bolts
- (4) M16 Self-locking Nuts
- (16) M16 Washers

Tighten mast hardware following the sequence to the right:

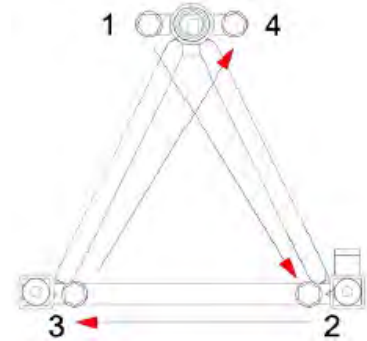

6.8.3 Preparing the machine's functionality before connecting the power supply

Before connecting the power supply, in order to prepare the machine for this, proceed as follows:

- ensure that the braking cams used to stop when going down and for the lower over-travel, are present and positioned correctly
- ensure that the hatch of the base and onboard electrical control panel are closed properly
- ensure that the main power switch of the base and onboard control panel is in the “0” position
- ensure that appropriate closure caps are fitted on all the other multi-pin connectors which are not in use
- verify the integrity of the electric power and control cable

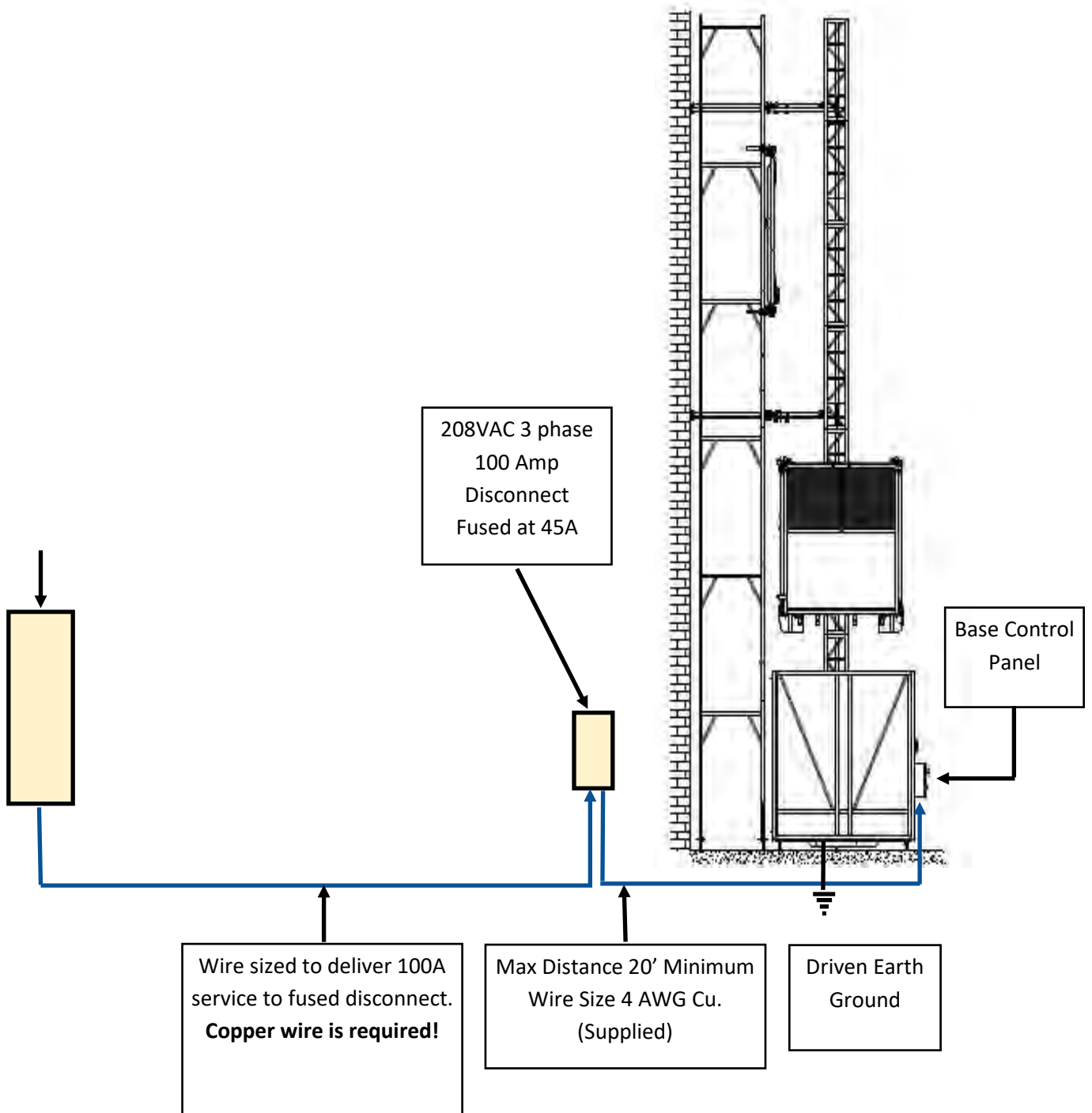

Figure 6.10

6.8.4 Connecting the power supply

Once the machine is set in place, proceed to connect it to the power supply as described below:

- the installer is responsible for connecting the power supply and he must use a type of electric cable which is suitable for the relative installation. In any case, when preparing the power line, you must be particularly careful in choosing a path for the electric cable, making sure that this cannot be immersed in water, trampled on by persons or any type of vehicles even if they have rubber wheels, operating in the construction site. If the power line is to be elevated, this must be marked with proper signs and placed high enough to ensure absolute safety for all that passes below. Proper signs have to be set in place even if the power line is buried underground, in order to prevent risks caused by excavation or earth moving machinery
- the electrical load of the unit is located at the hoist basket which travels up and down the mast tower and not at the base of the unit. **When sizing for the correct cable size to supply power to the hoist; the required load, distance from the supply power to the base of the unit, and the length of the trailing cable (not the mast height) needs to be calculated to minimize voltage drop to the unit.**

(MINIMUM SIZE SUPPLY CABLE IS 4 CONDUCTORS OF 4AWG)

- connect the device to the power line, which is equipped with an earth connection, a magneto thermic switch with appropriate power to protect the power line and a differential circuit breaker switch
- check that the supply voltage corresponds to that of the electric motors and to the data shown on the machine's identification plate. Ensure the phasing of the supply voltage is correct, correct the phasing that the base of the unit at the location where the supply power is connected. Never change the phasing between the ground control box and onboard control box
- implement the machine's earth and lightning protection system with the use of the special bolt appropriately marked on the base unit. Ensure that the earth connection is implemented with a conductor having a cross-section which is not less than that of the relative power line conductor.

6.8.5 The first handling process of the machine

Once the electrical connection of the machine is implemented, it is good practice to move on to handling the loading unit to verify its functionality.

Proceed as described below for the handling process of the machine:

- the electrical control panel installed onboard is locked with a key which is to be kept exclusively by the system maintenance technician. A copy of the wiring diagram must be kept near the electrical control panel, and this must include the safety circuits. Upon each installation of the machine, there must be a free space left in front of the electrical base control panel, of at least 24 in. to facilitate opening the hatch to carry out any inspections needed
- place the electric cable in such a way as to ensure it goes up and down smoothly
- before supplying electrical power, check the position and correct functionality of the safety main switches found inside the electrical control panel

- check that the emergency pushbuttons of the base control panel and the onboard control panel is pressed

DANGER:

The stages described below must be carried out with the operator on the ground and the cabin completely unloaded and free from any kind of material.

- rotate the emergency push buttons in the same direction as the arrows
- switch the main switch on the base control panel to the “ON” position
- switch the main switch on the onboard control panel to the “ON” position

The machine will be ready for the handling process.

DANGER:

Before proceeding with the handling process of the machine, verify and ensure that all the stop position and safety devices function properly.

- set the main switch on the onboard control panel to the “OFF” position
- locate the DROP TEST PENDANT
- remove the jumper plug and connect the cable of the DROP TEST PENDANT to the onboard control panel
- set the machine mode key switch to the first position “ERECTION”
- set the main switch on the onboard control panel to the “ON” position.

The DISPLAY screen will display:

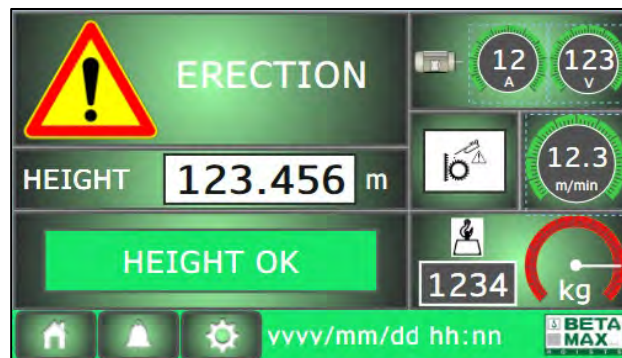

Figure 6.11

WARNING:

In ERECTION mode the outside controls are automatically disabled, exception is the emergency devices (EMERGENCY pushbuttons, limit switches).

- close all doors
- using the drop test pendant UP push button drive the loading unit to a height of 10 feet, this process by-passes the down over-travel limit switch
- set the main switch on the onboard control panel to the “OFF” position
- remove the cable of the DROP TEST PENDANT from the onboard control panel and re-install the jumper plug
- set the main switch the onboard control panel to “ON” position.
- press and release the emergency push buttons found on the control panels, open and close the access doors of the loading unit and of the base enclosure, open and close the folding platform used to mount the anchors; with each one of these operations, you must hear the main contactor go on and off inside the electrical control panel onboard the loading unit
- while in “ERECTION” mode, try and press the INCREASE FLOOR pushbutton on the control panel, while implementing each one of the following one at a time, pressing the emergency pushbutton, keeping an access door of the loading unit open, keeping the anchor assembly platform open

DANGER:

In each one of these conditions, the machine must not move in any way, otherwise, shutdown it and immediately contact BETA MAX technical support.

- restore all the machine’s operating conditions and press the INCREASE FLOOR push button on the onboard control panel for a short while, the cabin will move in this direction stopping when the push button is released.
- implement the same operation but press the DECREASE FLOOR push button; ensure that the machine stops correctly on the downward end-of-travel pad.
- implement this operation two or three times, checking the constant behavior of the machine.
- At this point, if the checks have been positive, start the assembly stage.

DANGER:

The operations described below are intrinsically more dangerous, usually having substantial heights in respect to the ground; extreme caution is recommended in carrying out each operation and unconditional conformity with all the rules and warnings stipulated below.

To carry out the installation process of the machine, it is necessary to wear all the individual protection gear, as expected; all procedures must be strictly complied with and also in the same chronological order as given in this manual; and solely persons who have been properly trained and specifically authorized must carry out operations. The safety of the persons who carry out operations may be seriously put at risk by the total or partial non-compliance with the instructions given until now in respect to the correct preparation of the machine and the site where it is installed.

DANGER:

Adhere to all the indications, in a meticulous manner, pertaining to the weights and measurements of the loads stipulated in the paragraph titled "DIMENSIONS AND CAPACITIES" and unconditionally comply with all the rules and warnings stipulated below.

During the assembly stage only two operators are allowed on the machine and a maximum load of 500 lbs. In the absence of the hoist used for mounting the masts, two persons are recommended to be present to handle the masts themselves in an easier manner, however, in any case it is absolutely forbidden for more than two persons to be onboard, irrespective of the operating conditions. The material loaded onto the machine must be absolutely contained within its perimeter, ensuring that no component protrudes beyond this. During the handling process of the machine, persons and material must be within its perimeter, for no reason whatsoever, should things or persons be dangling or located outside the loading unit. The operator who maneuvers the control devices, prior to handling the machine, must ensure that the other person, if present, is located inside the cabin, in safe conditions, and must keep this person informed, always, about the maneuver he intends to implement. Once the desired position is reached, to carry out the particular operation, the emergency push button must be pressed, and must remain like this till machine movement is required. The above-mentioned procedure must be followed for every move.

DANGER:

An incorrect assessment of the installation conditions is the greatest and most common cause of accidents.

DANGER:

Independently from the number of mast sections you carry with you during the erection, you must follow specific assembling instructions concerning anchorages. The consecutive assembling of mast sections, without having fixed the anchorage as indicated in the manual it's absolutely forbidden.

6.8.6 Machine parameters

To access the machine parameters, press the gear shaped symbol on the lower portion of the touch screen.



Access to page with "MACHINE PARAMETERS"



Protect the password from an unintentional use!

Only trained technicians should have access to the password!

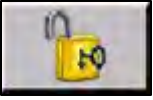

To insert the password:

1234	Press the area with “1234” ¹ , the display will show a numeric keypad: insert the correct password.
	Confirm the password pressing on “PADLOCK” (unlocking button). If the password is wrong, the display will return to the previous page.

Parameters Screen 1:

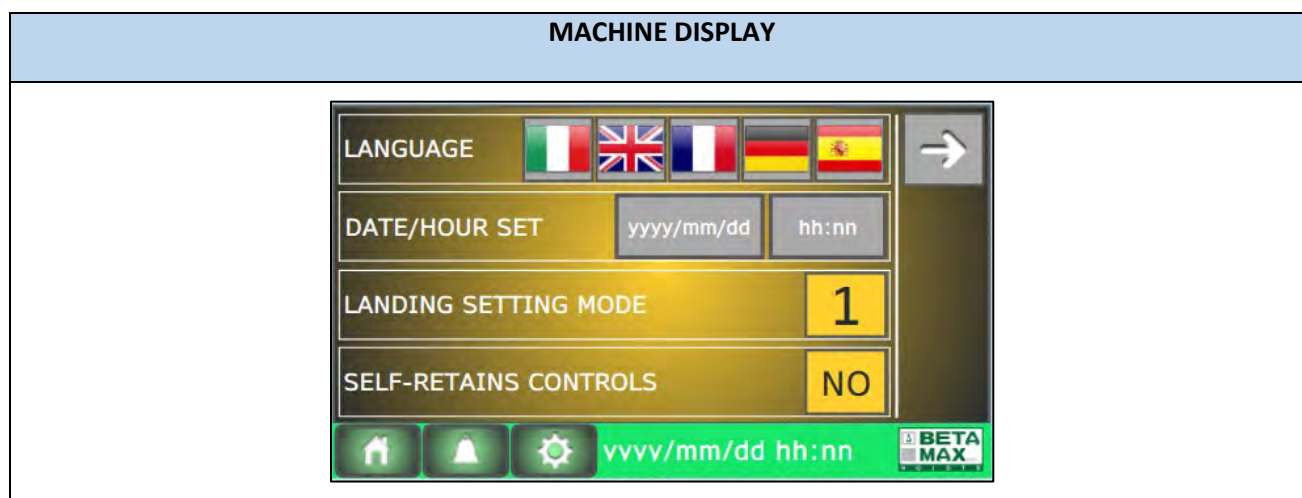

Settings:

Line 1	Language: select the language on the display pressing once on the flag (Italian, English, French, German, Spanish).
Line 2	System settings: set parameters such as date and time. Pressing over the number, a keypad will show data to modify. Once the modifications are made, press “ENTER” to confirm and exit.
Line 3	Landing setting mode: (values 1 or 2) [1] in normal use the arrows (up/down) allow to increase or decrease the selection of destination floors. [2] the UP button sets the max. settled floor and DOWN arrow the lowest (0 or -1, -2, -3...).
Line 4	Self-retain commands: (values YES or NO, in normal use”)

¹ The number “1234” is not a password. Contact BETA MAX Technical support for your password.

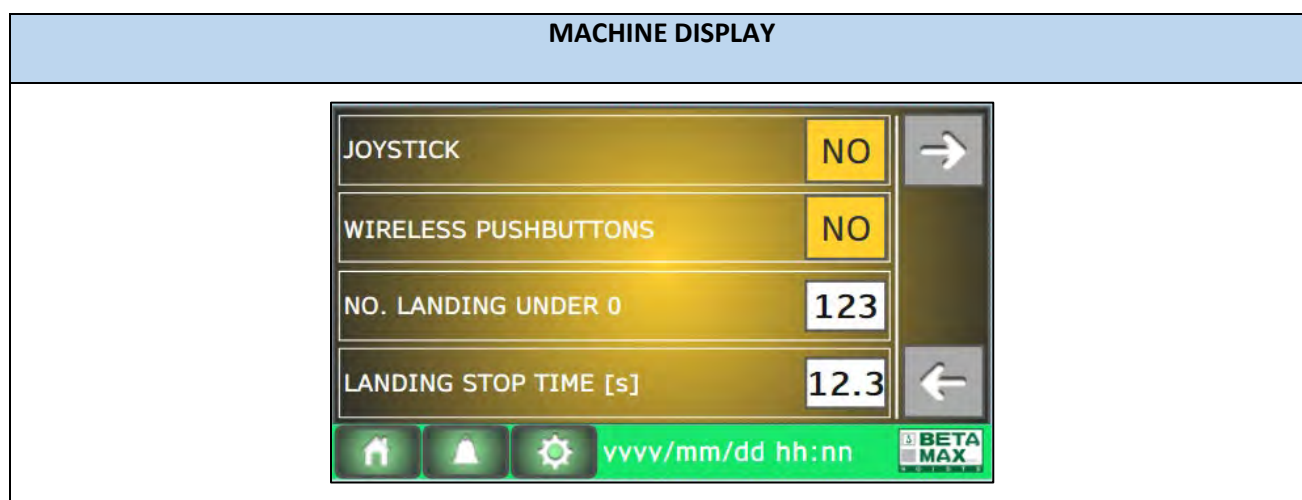

	<p>[YES], machine runs upwards to selected floor after having pressed the green button go to floor”.</p> <p>[NO] to move the machine, keep the green button “Send to floor” pressed.</p>	
		<p>Next Page</p>

Parameters screen page 2:



Settings:

Line 1	<p>JOYSTICK: (Values YES and NO)</p> <p>These values must not to be modified if the machine is without joystick.</p> <p>[YES] Mode Joystick activated</p> <p>[NO] Mode Joystick de-activated</p>
Line 2	<p>Wireless pushbuttons: (values YES and NO)</p> <p>[YES] machine with floor wireless call stations.</p> <p>[NO] machine with standard floor call stations.</p>
Line 3	<p>No. Landings under 0: (values from 0 to max. memorized floor)</p>

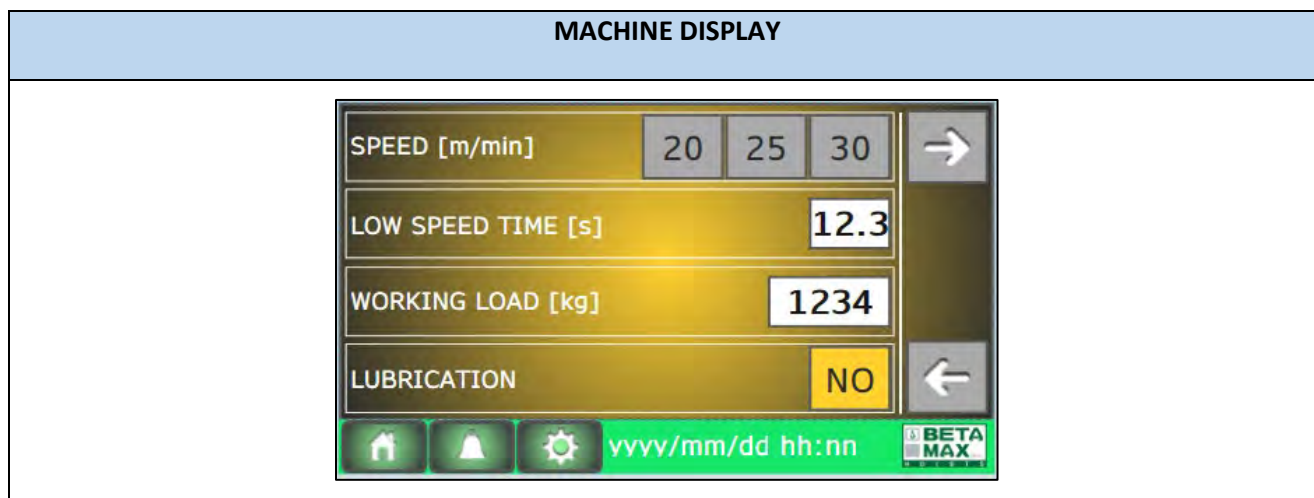

	<p>It allows the setting of floors under 0 to be selected in mode “Normal Use”. Set correct value after floors store with machine in “Normal Use”.</p> <p><i>Example:</i></p> <p><i>if there are 5 floors, 3 under “0” and 2 above “0” set machine value 3 and the display will in “Normal use” will show:</i></p> <ul style="list-style-type: none"> - floor -3 = floor 0 (bottom ultimate stopping cam) - floor -2 = floor memorized with 1 - floor -1 = floor memorized with 2 - floor 0 = floor memorized 3 - floor 1 = floor memorized 4 - floor 2 = floor memorized 5 	
Line 4	<p>Landing stop time [s]: (values from 00.0 to 10.0 seconds)</p> <p>Click on the field, insert the value on the keypad and confirm pressing the button (sending) to confirm.</p>	
	<p>Previous page</p>	 <p>Next page</p>

Parameters screen 3:



Settings:

Line 1	<p>Speed (m/min): (values 20,25,30)</p> <p>Select button according to desired max. speed in “normal use”:</p> <p>[20] max. speed 20 m/min</p>
--------	---

	<p>[25] max. speed 25 m/min</p> <p>[30] max. speed 30 m/min</p> <p>Selected button has a different colour.</p>		
Line 2	<p>Time low speed (s): (values from 00.0 to 10.0 seconds)</p> <p>Click on the field, insert desired time for departure in low speed on keypad, confirm pressing the button “Sending”.</p> <p>It is possible to decide the time in seconds the machine runs in low speed while leaving a floor in “Normal use”. After time lead-time, machine will reach the selected max. speed (Line 1).</p>		
Line 3	<p>Working load (kg): (values from da 0 to 5500)</p> <p>Click on the field, insert value on the keypad appears on the display and confirm pressing button Enter key.</p> <p><i>(Parameter only for correct visualization of the weight when a bar-graph area is configured on a special display. This does not change the loadcell calibration setting.)</i></p>		
Line 4	<p>Lubrication: (values YES and NO)</p> <p>[ON] lubricating pump activates when machine runs upwards in “Normal Use”.</p> <p>[OFF] pump off</p>		
	Previous page		Next page

Parameters screen 4:

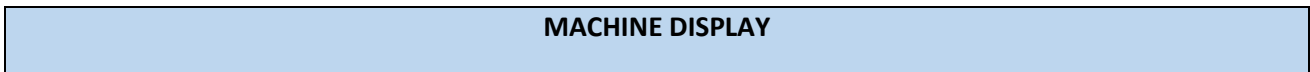



Settings:

Line 1	<p>ALARM SELF RESET: (values YES and NO)</p> <p>[YES] = All the alarm are reset itself after 5 seconds.</p> <p>[NO] = Some alarm must be reset with the dedicated pushbuttons once appears.</p>
Line 2	--
Line 3	--
Line 4	<p>RUNNING HOURS: (hhhhh, mm, ss)</p> <p>This line (only visualization) shows hours of machine work (hours/minutes/seconds). The numbers on the first box are the hours, the other boxes are minutes and seconds. This value increases only when machine is running upwards /downwards.</p>
	<p>Previous page</p>

6.9 MOUNTING THE MAST AND THE FIRST WALL ANCHOR

The instructions provided below pertain to the installation of the first wall anchor and the assembly of the mast, assuming that the first component of the vertical mast has already been installed on that of the base unit, for the first leveling procedure of the machine.

Bear in mind that in order to prevent it from tipping over, the first wall anchor must be implemented at a maximum height of 9.84 ft from the ground and is for temporary use. The next wall anchor will be installed at a maximum height of 19.68 ft from the ground. Once installed the temporary wall anchor can be removed.

DANGER:

To install a particular anchor system in any manner not covered in this instruction manual, it is always necessary to contact BETA MAX Technical Support.

To mount the components constituting the mast, proceed as described below:

- mast sections in a maximum quantity of four pieces, with relevant bolts, washers, fastening nuts and all component needed to install the anchor have to be loaded on the loading unit. When positioning the masts onto the loading unit, be careful to place them upright with the part for the tapered couplings on the lower part, in an orderly manner and close to the lifting unit
- drive the cabin up to the limit of the mounted mast (two safety hooks are provided to prevent it from dropping down, in case of an incorrect maneuver being implemented)
- remove mast guard using a 13mm socket or wrench, (4) 8mm bolts, one in each corner
- remove roof hatch prop rod from its stowage. Unlock roof hatch by sliding padlock toward the center of the car. Install roof hatch prop rod and lift roof hatch upward. Secure roof hatch prop rod with supplied locking pin. **CAUTION: DO NOT LEAVE ROOF HATCH OPEN WITHOUT SECURING WITH PROP ROD.**

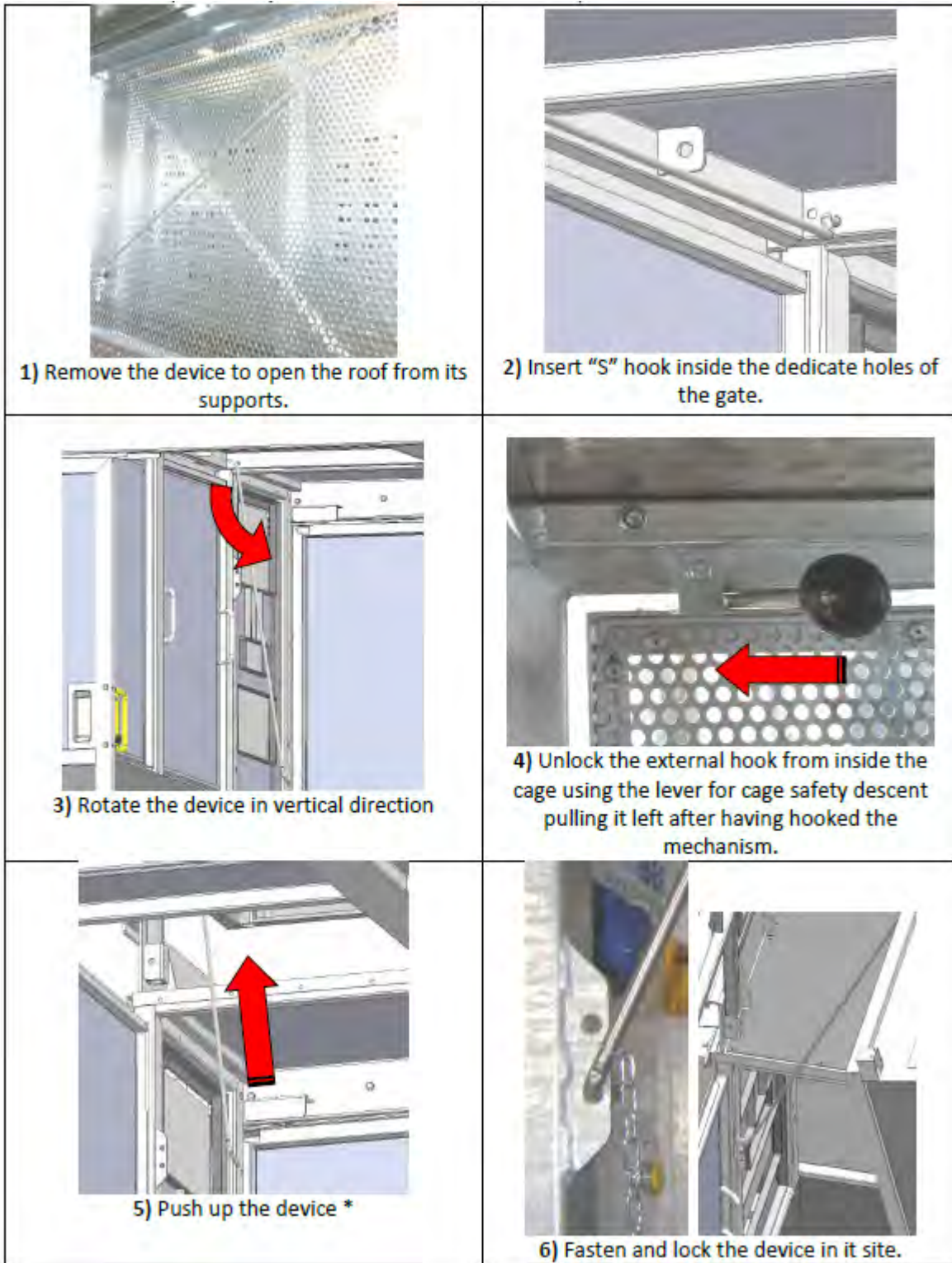

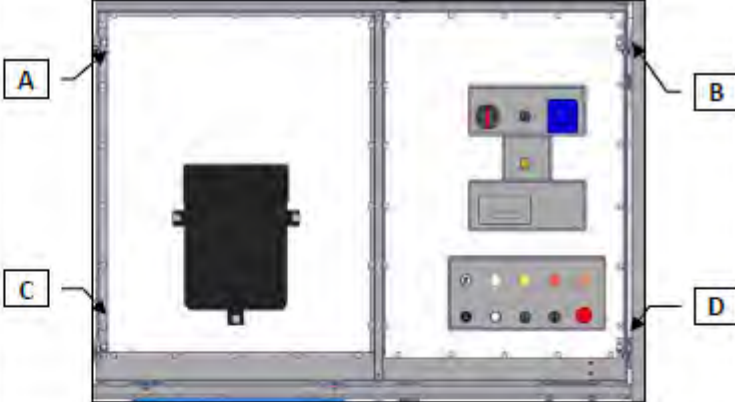
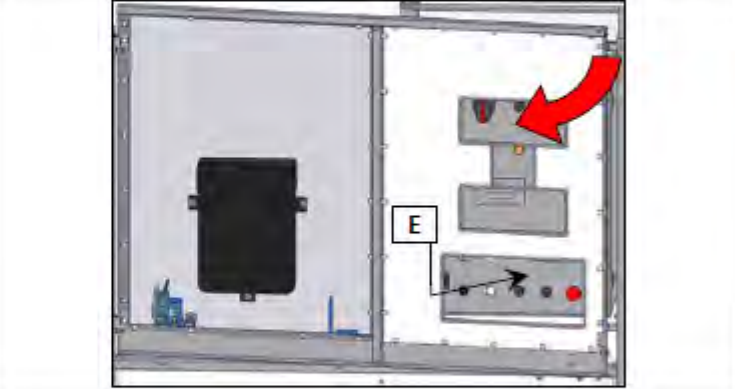
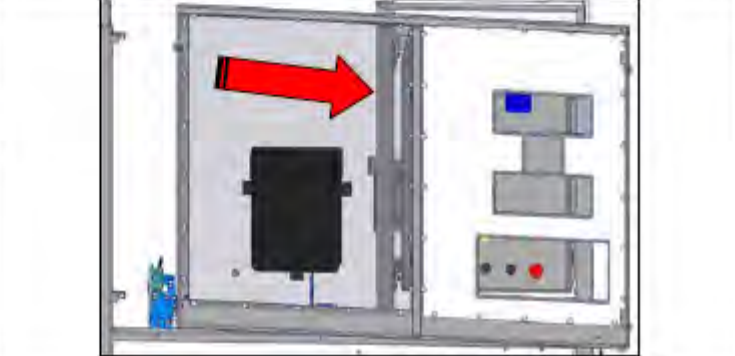
<p>Unlock the roof: remove (A) and (B) screws and (C) and (D) nuts.</p>	
<p>Grasp the grid from (E): pull it keeping pressed its left part.</p>	
<p>Pull a little bit right to remove it from its side.</p> <p>To close, repeat the operations anti-clockwise, fix with utmost care the bolts and nuts.</p>	

- if a crane is not available, two persons can lift the mast by positioning themselves one on each side to position the mast on top of the previous one and block it as described above
- you are advised to insert the bolts between two masts starting from the lower part and moving upwards as shown in *figure 6.9* so that, in an unfortunate instance of a nut becoming loose, the bolt can fall, making it clear that it is missing during a subsequent control. It is certainly more evident and visible, even at a glance, if the entire bolt is missing as opposed to only the nut

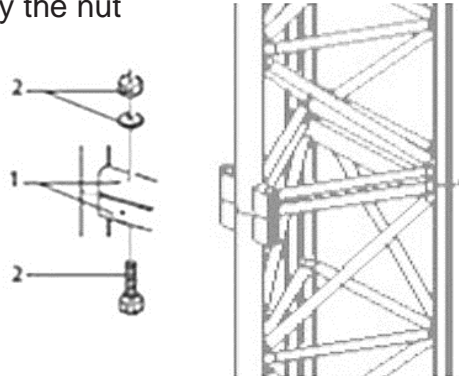

ATTENTION:

For mast section fitting you can use only:

- Bolts M16x160mm grade 8.8
- Self-locking nuts M16
- Washers, flat M16

- when mounting a mast on top of another, take care to ensure that the two support surfaces are perfectly clean and free from any residue; carefully tighten the fastening bolts (refer to the table that indicates the correct tightening torques in respect to the particular bolt). Ensure that the two extreme ends of the masts which come into contact fit perfectly with no ridges between the main vertical supports or between the racks, (no residual air must remain in between the surfaces when they come into contact). If the connection between two masts does not seem to be perfect or does not comply with the instructions provided earlier on, shut down the machine and contact BETA MAX Technical Support immediately
- before handling the machine, ensure that the masts are perfectly mounted and tightened
- Close and latch roof hatch, returning roof hatch prop rod to its stowage
- Reinstall mast guard **CAUTION: DO NOT OPERATE THE MACHINE WITH ROOF HATCH OPEN OR WITHOUT THE MAST GUARD PROPERLY IN PLACE.**

DANGER:

Failure to utilize roof hatch prop rod may result in roof hatch closing prematurely.
THIS MAY RESULT IN SERIOUS INJURY OR DEATH.

- Regardless of whether the assembly or disassembly process is being carried out on the machine, driving the cabin on a mast which is either partially tightened or not tightened at all, could cause the component to detach itself immediately, resulting in the loading unit dropping down. As yet, systems or means to prevent the operator from making such a serious mistake are not known

DANGER!

Driving the machine on a mast that has a component which is either partially tightened or not tightened at all, could cause the component to drop down immediately. An ACCIDENT OF THIS NATURE WOULD CERTAINLY CAUSE THE DEATH OF THE OPERATORS ONBOARD THE MACHINE.

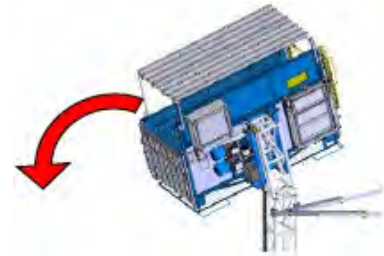

ATTENTION:

DO NOT install the mast if you do not have enough hardware or the tools required! Return to the base level to acquire the needed components!

- before moving on to another operation, terminate the operation being carried out; never carry out two or more operations at the same time, when delegating particular tasks to others always verify the result
- before mounting the wall anchor, check the verticality of the mast with the use of a spirit level and by using two sides of the rack as a reference plane; check the mast's verticality, as described earlier on. Carry out this procedure on the last mast installed, bearing in mind that the higher this verification is carried out, the more the leveling will be correct, since the difference generated by the angle of inclination in respect to the ground will be amplified
- in case of incorrect leveling, disposing of a machine without support feet, to correct the eventual errors of installation, operate on the supporting surface so as to ensure the horizontally and the stability of the whole
- in the case of incorrect leveling, disposing of a machine with support feet, operate on the support feet up to reach the condition of verticality

DANGER:

The leveling of the machine and the mast is a very important process. The mast must be positioned in conditions of absolute verticality; inclinations that exceed 1 degree are not permitted.

- at this point, implement the wall anchor while referring to the instructions given in the next paragraph

DANGER:

It is absolutely necessary for individual protection gear to be worn during these operations, such as hard hats, gloves, safety shoes with toecaps, etc.

DANGER:

An incorrect assessment of the installation conditions is the greatest and most common cause of accidents, often with a fatal outcome.

6.10 MOUNTING THE ANCHORS

The operator must be certain of the forces exerted by the anchor system onto the structure in question and verify that the structure is suitable to withstand them; he must make the right choice when deciding upon the mounting components in accordance with the facade's walling. If the machine is anchored to traditional scaffolding, the layout must be considered appropriately. Any layout of anchors which is not given in this manual may only be implemented if it has been brought to the attention of an explicit authorization is given by BETA MAX. The implementation of the anchors must be carried out solely by means of the proper mounting platform, or by using methods of equal efficacy and safety, such as hydraulic baskets, traditional scaffolding towers, balconies which the building may have etc. However, individual protection gear must be utilized anyway, such as a safety harness, hard hat, safety shoes and gloves. It is absolutely prohibited to lean over or operate from outside the platform used for mounting the anchors or the loading unit; any operation must be carried out from inside the structures mentioned earlier on, or by utilizing means which have similar safety features. It is also absolutely prohibited to climb onto and all the more to operate from the vertical mast or any other protruding part of the machine, BETA MAX disclaims all responsibility in the instance of operating in conditions which are not specifically authorized or all the more in conditions which are specifically prohibited.

BETA MAX also disclaims all responsibility for causes due to the implementation of particular anchor systems which are not defined nor authorized beforehand by the manufacturer. BETA MAX also disclaims all responsibility for anchor systems which are not implemented up to standard even if specifically allowed by the manufacturer; this makes it an obligation to contact Technical Support every time a particular installation is necessary.

IMPORTANT: The supervisor has the explicit task of supervising and giving adequate instructions on good practice by providing safety procedures for the implementation of such work, ensuring that individual protection gear is used and that the work is carried out in authorized places, supervising the quality of work, for example, ensuring that drills with adequate diameters are used, the holes are of the right depth, that bolts and clamps are tightened in accordance with established torque values etc.

DANGER:

An approximate assessment of the installation conditions is the greatest and most common cause of accidents.

To mount the anchors, proceed as described below:

- ensure that the wall onto which the anchors are to be mounted can sustain the intended horizontal forces in order to sustain the machine (refer to Chapter *"Forces onto the wall anchor system"* in this manual);
- choose the most suitable type of fasteners for the type of walling present; take care in ensuring that the fasteners used are of suitable measurements to sustain the forces exerted (refer to Chapter *"Forces onto the wall anchor system"* in this manual)

- raise the cabin to the intended height and press the emergency push button found on the assembly keyboard. Bear in mind that it is obligatory for the operator/s to be within the perimeter of the mounting platform during the handling process of the machine. Solely one operator is allowed on the anchor assembly platform
- fasten the safety harness to the proper bracket and lower the folding platform by releasing the locking device

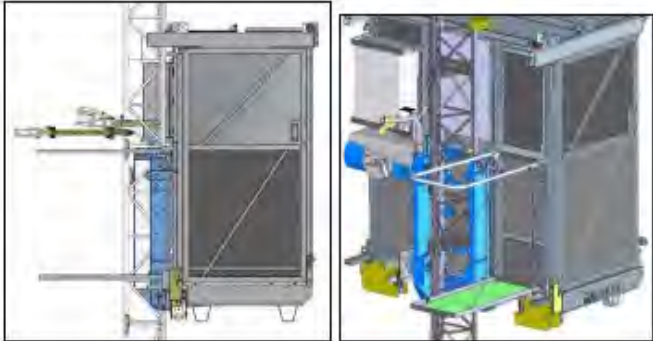
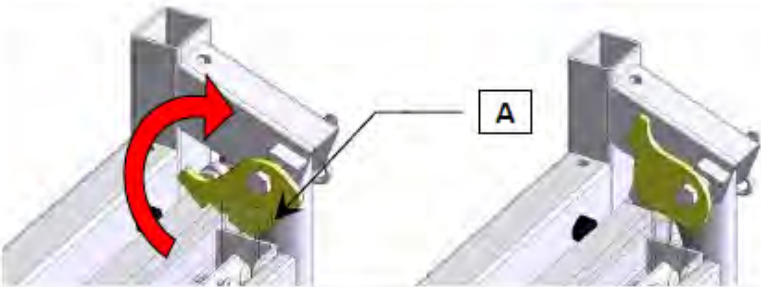
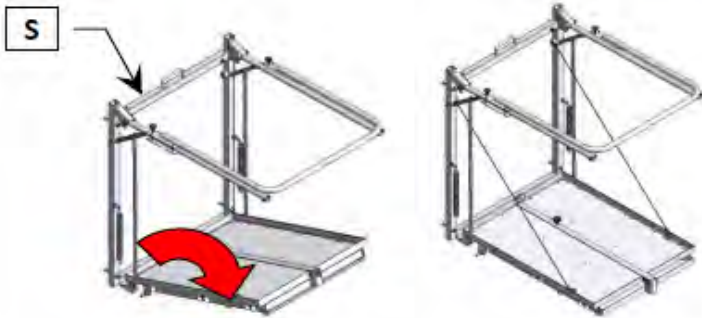
<p>Stop the hoist to suitable height to install the tie. Upper part of machine parapet (h=1,1m) must be under installation height of the tie. (as shown here right)</p>	
<p>Pull the erector platform to allow the lifting of both locking devices to release them (A).</p>	
<p>Push the platform to open it in horizontal position. A special mechanism allows to lower the platform and position a safety bar horizontally. At this step, the platform is ready for use. Before entering, secure yourself hooking to the dedicated "S" point.</p>	

- step onto the folding platform whilst keeping the safety harness on and ensuring it is fastened to the proper bracket

DANGER:

Bear in mind that only one person can work on the anchor assembly platform, and it is absolutely prohibited to pile up material on this. All material must be left on the loading unit and be passed, one at a time, by the operator who is on the loading unit. It is only permissible to keep tools on the mounting platform, which are strictly necessary, such as the drill, hammer, wrenches, etc.

- for machines using standard wall anchors install the two anchor extension bars (1) and (2), one perpendicular to the wall itself, the other inclined to the desired distance to the rear part of the mast. Ensure the holes are drilled properly and the supporting feet have a perfect hold (3) and place the perpendicular clamps (4) between the anchor extension and the vertical rods of the mast and the adjustable clamps (5) between the two extensions
- apply the toggle bolts and tighten everything, including the clamps

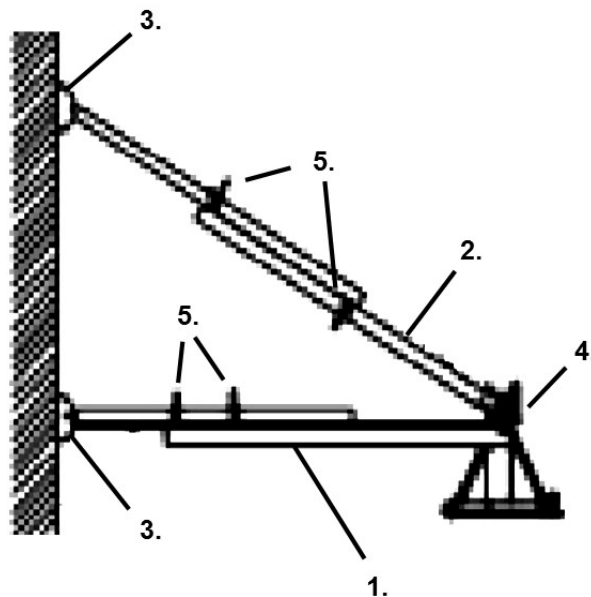

Figure 6.12

- the anchor extensions must not be inclined more than 5° in respect to their horizontal position; ensure that the feet of the extensions are in perfect contact with the wall; if a dowel seems to be even partially out, carry out its procedure again; ensure that all the bolts and clamps are tightened correctly and effectively
- with the use of a spirit level, check the verticality of the mast and if necessary, loosen only the components relative to the correction and implement the necessary adjustment regarding the verticality. Once this is obtained, carefully tighten, once again, all the parts which were previously loosened
- go back on board the loading unit and raise the platform used for mounting the anchors. A safety device prevents the machine from moving if the platform is not put back into place correctly; carry out this operation while keeping the safety harness on and fastened
- repeat the mounting operation, as described earlier on, until reaching the desired height, in any case and always refer to the layouts of the anchor systems given in this instruction manual
- if assembly is carried out under a roof or below eaves, ensure that at the top of the mast, there is the necessary space that is established by construction regulations in force
- apply the top mast section to the top end of the mast and verify its correct functionality
- implement a few trial movements to verify the stability of assembly and regularity of operation.

DANGER:

It is absolutely necessary for individual protection gear to be worn during these operations, such as hard hats, gloves, safety shoes with toe-caps etc. An approximate assessment of the installation conditions is the greatest and most common cause of accidents.

DANGER:

In order to install a particular anchor system or in any case one that is not considered in this instruction manual, it is always necessary to contact Beta Max Technical Support.

6.11 MOUNTING THE ELECTRIC CABLE GUIDE

The frames of the electric cable guide must be mounted simultaneously with the assembly of the masts and also with the implementation of the wall anchors. In doing so, the cabin gains height whilst the installation processes are completed. Even during the machine's installation process, the electric cable must not be left loose as any swinging effect can cause it to get entangled with the machine's components or the structure in question. Every time a part of the mast is installed and reaches a length equal to the recommended interval in between the cable guide, set the frames in place immediately.

To mount the cable guide, proceed as described below, with reference to figure:

- mount the cable guide on the rear rods of the vertical mast; fasten it with the appropriate clamps and verify the correct alignment with the cable container. The first cable guide must be mounted at a height of 14 ft (from the base, the second at a distance of 15 ft from the first one and subsequently at intervals of 15 ft, as shown in figure
- ensure that the cable puller is centered with the cable guide
- ensure that the cable guide is kept at a short distance from the machine when this is positioned to stop at a floor level

The distance to be applied between the cable guide frames as suggested earlier on is to be considered a general guideline. This distance can vary, generally reducing the distance between the frames of the cable guide, depending on the necessity and in accordance with the particular windiness of the area where the machine is installed.

DANGER:

It is absolutely necessary for individual protection gear to be worn during these operations, such as hard hats, gloves, safety shoes with toecaps, etc.

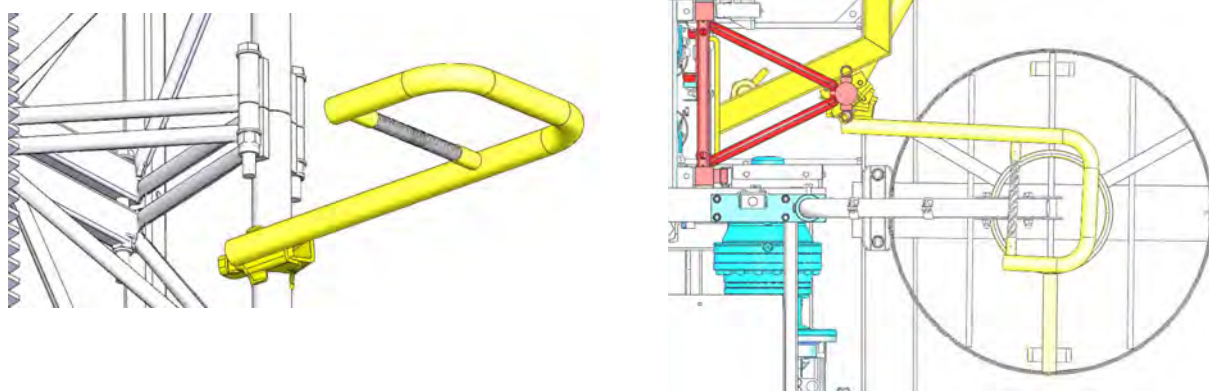

Figure 6.13

6.12 MOUNTING SUBSEQUENT MASTS

To mount the components constituting the mast, proceed as described below:

- not more than four components, which constitute the mast, are to be loaded onto the cabin and these are inclusive of the relative bolts, washers, fastening nuts. When positioning the masts onto the loading unit, be careful to place them upright with the part for the tapered couplings on the lower part, in an orderly manner and close to the motorized part of the lifting unit
- for the subsequent operations, proceed as described in paragraph 6.7, meticulously following all the instructions given in the various points
- before handling the machine, ensure that the masts are perfectly mounted and tightened. For both the assembly and disassembly operations, driving the loading unit on a mast which is either partially tightened or not tightened at all could cause the component to detach itself immediately, resulting in the loading unit dropping down. As yet, systems or means to prevent the operator from making such a serious mistake are not known

DANGER:

Driving the loading unit on a mast that has a component which is either partially tightened or not tightened at all could cause the loading unit to drop down immediately. A SIMILAR ACCIDENT WOULD CERTAINLY CAUSE THE DEATH OF THE OPERATORS ONBOARD THE MACHINE.

DANGER:

It is absolutely necessary for individual protection gear to be worn during these operations, such as hard hats, gloves, safety shoes with toecaps, etc.

6.13 MOUNTING OF LANDING AND SLOWDOWN PADS

6.13.1 Landing pads

The base unit is supplied with the downward end-of-travel and slowdown pad (1) and the downward over-travel pad (2) already installed, as shown in figure and appropriately adjusted to be able to operate at the minimum height from the ground. In normal operating conditions, the downward end-of-travel and slowdown pad (1) has the function of slowing down the downward travel and stopping the cabin at the right height from the ground. The downward over-travel pad (2) (which is also a safety device) intervenes by stopping the cabin and interrupting the power supply, if the normal downward end-of-travel malfunctions or is damaged. If the over-travel pad intervenes when the normal downward end-of-travel is in good operating conditions, this indicates the machine is malfunctioning. Two probable causes are the downward slowdown limit switch is not functioning properly or an increase in the braking distance, due to excessive wear and tear or poor adjustment of the motor brake.

ATTENTION:

When this occurs, before using the machine again, you must identify and remove the cause which led to the malfunction.

To regulate the stopping position of the cabin, you just have to slide the pad accordingly on the appropriate eyelets that support the pads.

Once the masts are assembled, install the top safety mast containing the upper end-of-travel and slowdown pad (3) and the upward over-travel pad (4), as shown in figure. Perform various maneuvers to verify the correct operation of the stop.

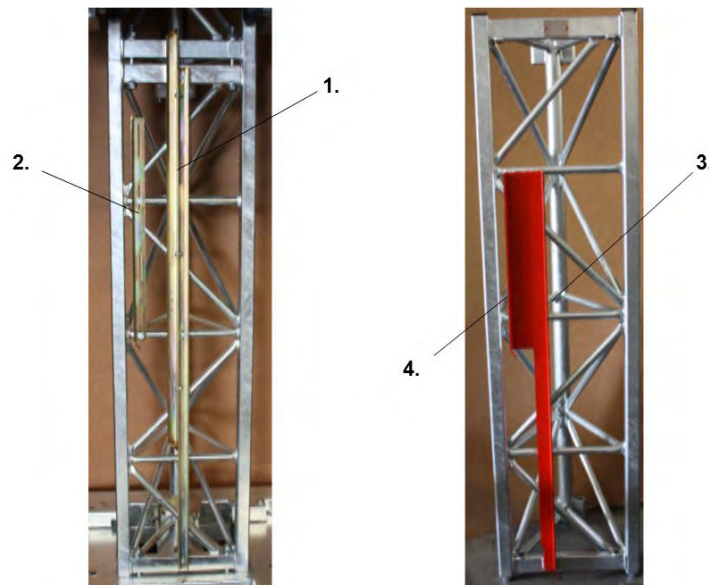

Figure 6.14

6.13.2 Floor level braking pads (floor stop)

The MC2000PMB V does not require floor level braking pads. The floor level braking is controlled electronically through the programming of floors.

6.13.2.1 *Floor level programming*

DANGER:

Floor level locations are to be programmed by qualified technicians only.

Use the “PROGRAMMING” mode to record the different landing locations and the programming of the cabin doors to unlock at each location. It is recommended to begin programming from floor number “0” and go in sequence in an upward order and only after installing all landing doors. The programming of the cabin doors allows for opening of the right cabin door, the left cabin door, or both cabin doors at any floor location.

NOTE:

The ground level position and/or floor landing level position must be recorded before programming the opening of the related cabin door.

To activate the machine functioning in this mode:

- rotate the emergency push buttons in the same direction as the arrows
- switch the main switch on the base control panel to the “ON” position
- switch the main switch on the onboard control panel to the “ON” position
- set the machine mode key switch to the second position “PROGRAMMING” (central)

The DISPLAY screen will display:

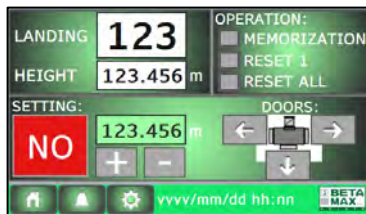

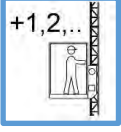
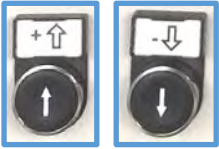



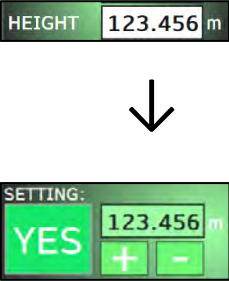





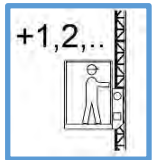
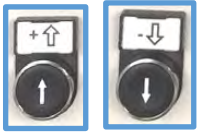



Figure 6.15

	Floor to store or modify.
	Distance in meters of cage loading deck from the ground.
	Floor memorized level
	Manual modification of level corresponding to memorized floor [+] = increase the value [-] = decrease the value
	If activated and blinking green: recording of selected floor in progress.
	If activated and blinking yellow: deleting of selected floor in progress.
	If activated and blinking red: delating of all floors in progress
	Floors recording: [NO] = floor not recorded [YES] = floor recorded
	Selection of direction for doors opening: FULL GREEN triangular allows machine doors opening to selected floor.

6.13.2.1.1 Setting floor locations

1		<p>Select mode “Assembly/dismantling” to move the hoist, to align machine deck to floor with landing door or gate.</p>
2		<p>Select mode “Floors recording”.</p>
3		<p>Choose the “Floor to store” using arrows buttons: “UP” “DOWN”</p>
4		<p>The display will show selected floor (landing).</p>
5		<p>Button “SEND TO FLOOR” Keep this button pressed more than 3 seconds to store a floor.</p>
6		<p>MEMORIZATION on the display will start to blink; keep it pressed and it will switch off. Release the button.</p>
7		<p>Quote h will be transferred to the case of selected floor. Once floor recorded, YES will appear. If necessary, correct the level acting on + and - on the display.</p>
8		<p>Select the door to unlock or open to that floor in “Normal use” pushing dedicated triangular. The image shows selected triangular right (area full green): to that floor only right door will open.</p>









6.13.2.1.2 *Cancel a single floor level recording*

1		<p>Select mode “Assembly/dismantling” to move the machine from ground level.</p>  <p>THE HOIST SHALL NEVER BE IN POSITION OF BOTTOM ULTIMATE LIMIT SWITCH.</p>
2		<p>Select mode “Floors recording”.</p>
3		<p>Select the “Floor to delete” acting with buttons with arrows:</p> <p>“UP”</p> <p>“DOWN”</p>
4		<p>The display will show the selected floor (landing).</p>
5		<p>Button “STOP NEXT LANDING”</p> <p>Keep this button pressed more than 3 seconds to delete the floor.</p>
6		<p>RESET 1 (Reset one) on the display will start to blink; keep it pressed till RESET 1 switch off. Release the button.</p>
7		<p>Selected floor will be deleted.</p> <p>When a floor is delated, the quote turns to zero and NO appears. With floor delating also door unlock is cancelled.</p>

6.13.2.1.3 Cancel all floor level locations

NOTE:

This function is very useful when changing jobsites and should be used at each new assembly of the machine.

1		<p>Select mode “Assembly/Dismantling” to move the hoist.</p> <p style="text-align: center;">  </p> <p>BRING THE HOIST TO GROUND LEVEL.</p>
2		Select mode “Floors recording” .
3		Select floor “ZERO” acting on arrow button: “DOWN”
4		The display will show floor “ZERO” .
5		Button “SEND TO GROUND” Keep it pressed more than 5 seconds to cancel all the floors.
6		RESET ALL on the display will start to blink; keep pressed till RESET ALL switch off . Release the button.
7		<p>All floors will be deleted.</p> <p>Once floors deleted, quote becomes zero with NO word. Solenoid settings also will be deleted.</p> <p>To level “0” all unlocking solenoids can be activated thus select the ones according to needs.</p>

6.13.3 Procedure check

After the memorization of all the floors is complete a check of the landing and slowdown pads must be performed. Perform the procedure as follows:

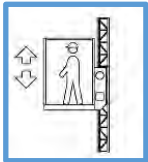

Turn the key selector **“WORKING MODES”** (Position 1, Error! Reference source not found.) to Pos. **“3”** (right) to activate **“NORMAL USE”**.

	<p>1st screen on display for control.</p>
	<p>Press button “ARROW UP” to lift the hoist: when the hoist is getting closer to upper cam it starts to decrease its speed. The quote corresponding to the up slow speed cam is memorized. Do NOT release the button.</p> <p><u>Arrow 1 on the display will become green</u></p>
	<p>Proceed upwards till machine stop. The quote corresponding to the upper stop limit switch will be memorized. Release the button.</p> <p><u>Arrow 2 on the display will become green.</u></p>
	<p>Press “DOWN ARROW” to lower the hoist: when the machine reaches the down stopping cam, it starts to decrease its speed. The quote corresponding to the slow down speed is memorized. Do NOT release the button.</p> <p><u>Arrow 3 on the display will become green.</u></p>

	<p>↑ 2</p> <p>↑ 1</p> <p>↓ 3</p> <p>↓ 4</p>	<p>CHECKING:</p> <p>2 = 123.456 m</p> <p>1 = 123.456 m</p> <p>3 = 123.456 m</p> <p>4 = 123.456 m</p> <p>MAX 123</p> <p>N 123</p> <p>N+1 123</p>	<p>Proceed downwards till machine stop. The quote corresponding to down stop limit switch will be memorized. Release the button.</p> <p><u>Arrow 4 on the display will become green.</u></p>
	<p>vvvv/mm/dd hh:nn</p>		

6.13.4 Procedure Verification

Once procedure is verified, the screen will show “**VERIFIED**” for a few seconds and machine will automatically proceed in Mode “**NORMAL USE**”.

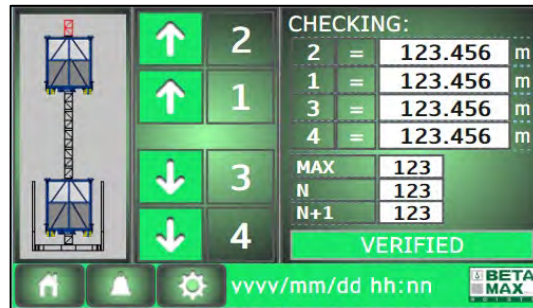

Figure 6.16

NOTE:

Remove the key from the “**WORKING MODES**” selector at the end of the final control phase.

NOTE:

Whenever there is a change in the “**WORKING MODES**” selector from “**Normal use**” to “**Assembly/dismantling**” or “**Programming**,” you must repeat the “**Procedure Check..**”

In case of any errors in floor settings, the system informs the operator.
 The DISPLAY screen will show “**ERROR**”:

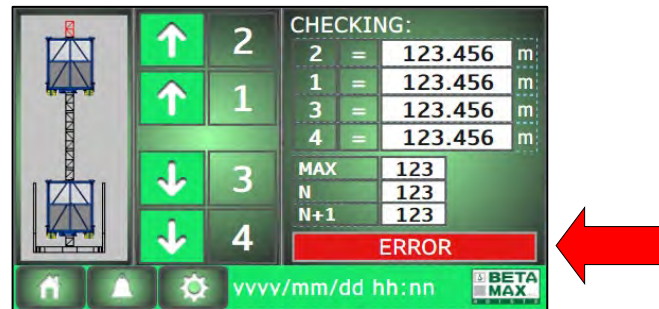

Figure 6.17

If an error in the floor setting has occurred, take note of **(2) and (3) number for max floor recognized “MAX”** in Figure 6.12. Turn the mode key switch to “**PROGRAMMING**” mode and check the recordings of the different floor levels at the floor with error **(N)** and **(N+1)**:

“**ERROR**” appears in the following situations:

- Floor landing memorized for a floor is lower than quote **(3)**. Floors must be recorded with machine above the slow down and down stop cam.
- Floor landing memorized for a floor is higher than quote **(1)**. Floors must be recorded with machine under terminal mast and slow speed stop cams upwards.
- Floor landing memorized for a floor lower than one of the previous floors; floors must be recorded in sequence from lowest to highest.

Check the recording of the indicated floor, and if necessary, the previous location and the next floor landing level.

Once the system procedure check has been completed, the machine is ready to be used in “**NORMAL**” mode.

6.13.5 Examples of floor level programming

6.13.5.1 *Example: recording of 2 floor levels*

- at the ground level, floor number “0”
- turn the machine mode key switch to the first position “ASSEMBLY/DISMANTLING”
- press the INCREASE FLOOR push button and position the machine at floor level 1
- turn the machine mode key switch to the second position “PROGRAMMING”
- press and hold the RUN/OPERATOR push button until the message “SETTING IN PROGRESS” disappears from the DISPLAY screen (approximately 5 seconds)
- set the door unlocking position by pressing the door position arrows on the DISPLAY screen
- turn the machine mode key switch to the first position “ASSEMBLY/DISMANTLING”
- press the INCREASE FLOOR push button and position the machine at floor level 2
- turn the machine mode key switch to the second position “PROGRAMMING”
- press and hold the RUN/OPERATOR push button until the message “SETTING IN PROGRESS” disappears from the DISPLAY screen (approximately 5 seconds)
- set the door unlocking position by pressing the door position arrows on the DISPLAY screen
- turn the machine mode key switch to the third position “NORMAL”
- run the systems procedure check by following the messages shown on the DISPLAY screen

Follow the same procedure to record any additional floor levels.

6.13.5.2 *Example: addition of a floor between 2 existing floors
(example between 5th and 6th floors)*

- turn the machine mode key switch to the first position “ASSEMBLY/DISMANTLING”
- press and hold the INCREASE FLOOR pushbutton to drive the machine to the extra level between recorded floors “5” and “6”
- position the machine at the additional floor level
- turn the machine mode key switch to the second position “PROGRAMMING”
- keep the RUN/OPERATOR push button pressed until the message “SETTING IN PROGRESS” disappears from the DISPLAY screen (approximately 5 seconds)
- check that the floor number on the DISPLAY screen reads “6”, if not, modify the value by pressing the INCREASE FLOOR pushbutton while in “PROGRAMMING” mode
- set the door unlocking position by pressing the door position arrows on the DISPLAY screen
- proceed by recording the floor numbers “7, 8, 9, etc...” with the same procedure
- turn the machine mode key switch to the third position “NORMAL”
- run the systems procedure check by following the messages shown on the DISPLAY screen

6.13.5.3 *Example: removal of a single floor level
(example floor number “5”)*

- in “NORMAL” mode run the machine to the recorded floor number “6”
- turn the machine mode key switch to the second position “PROGRAMMING”
- adjust the floor location from floor number “6” to floor number “5” by pressing the DECREASE FLOOR pushbutton
- keep the SEND TO FLOOR push button pressed until the message “SETTING IN PROGRESS” disappears from the DISPLAY screen (approximately 5 seconds)
- set the door unlocking position by pressing the door position arrows on the DISPLAY screen
- turn the machine mode key switch to the first position “ASSEMBLY/DISMANTLE”
- press and hold the INCREASE FLOOR pushbutton to drive the machine to the next floor level
- turn the machine mode key switch to the second position “PROGRAMMING”
- keep the RUN/OPERATOR push button pressed until the message “SETTING IN PROGRESS” disappears from the DISPLAY screen (approximately 5 seconds)
- set the door unlocking position by pressing the door position arrows on the DISPLAY screen
- proceed by recording the following floor numbers “6, 7, 8, etc...” with the same procedure



- turn the machine mode key switch to the third position “NORMAL”
- run the systems procedure check by following the messages shown on the DISPLAY screen

6.13.6 Wireless call station programming

ATTENTION:
 Wireless calls can only be installed by factory trained personnel.

6.13.6.1 System components

The wireless call system is composed of the following optional equipment:

1		<p>Receiver: The receiver is installed in the main control panel on the machine. It is connected to the units' network via an ethernet cable. The receiver can be programmed to receive information from the wireless call stations. The call stations buttons must be stored with a self-learning process (refer to subsequent sections).</p>
2		<p>Receiver Antenna: The antenna attaches to the top of the control panel rain guard via a magnetic base. It should be affixed in a vertical position.</p>

3		<p>Wireless Call Station: The call station consists of an UP and Down pushbutton. When pressed a coded signal is sent to the receiver which logs the landing requesting service.</p>
4		<p>Repeater: The repeater ensures signal strength for the wireless call system when total system height is greater than 30m (~100ft) or when there may be conflicting signals nearby. The repeater is installed inside the hoistway with the support oriented vertically. The repeater operates on 24VAC supplied on pins 1&2 of the connector.</p>
5		<p>Repeater Extension: The extension cord used to connect the repeater to the ground station. The length is 35m (~115ft).</p>
6		<p>Signal Divider for Extension Connection: The signal divider is used to connect more than 1 repeater to the system.</p>

7	 A photograph of a Base Panel Connection Kit cable. It features a black cable with a yellow-green braid at the top, a white plastic strain relief in the middle, and a grey metal connector at the bottom.	<p>Base Panel Connection Kit: This is installed to the base control panel and provides the connection for the repeater extension cable.</p>
---	---	--

6.13.6.2 *Example of component installation*

The following diagram depicts an example of a typical system installation:

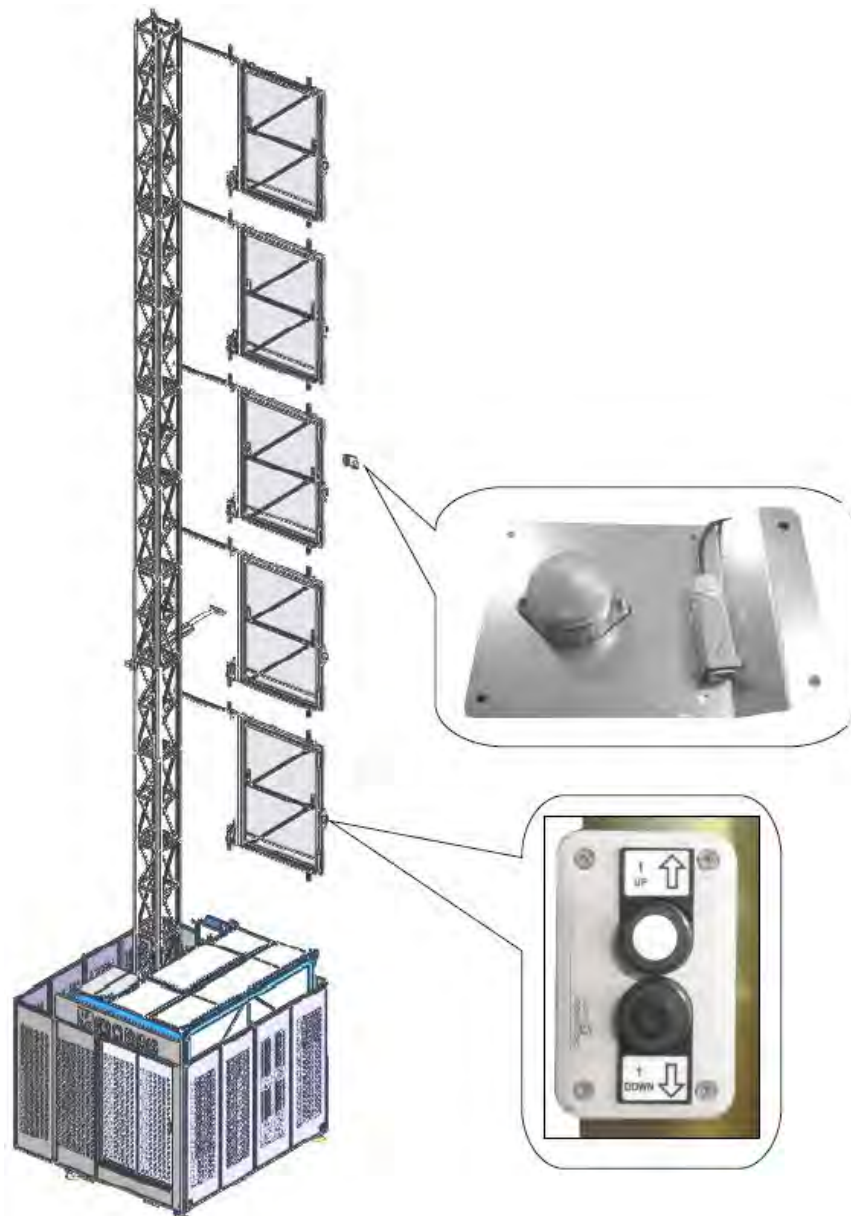





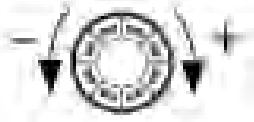















Figure 6.18









	<p>At any point: Push and hold the wheel selector for at least 3 seconds to return to RDY state.</p>
---	--



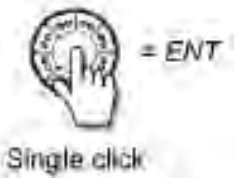

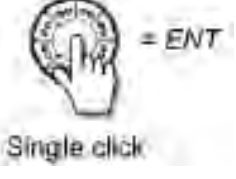

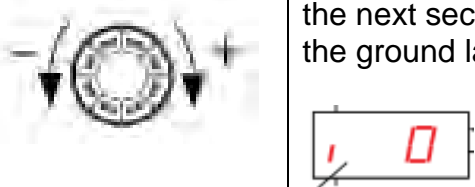

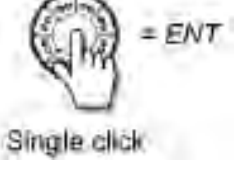

6.13.6.3.1 Clear all push buttons memorized in the receiver





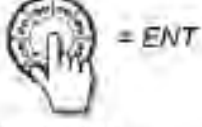

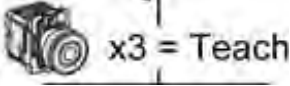



DISPLAY STATUS	ACTION	DESCRIPTION
		<p>Single Click, enter programming menu</p>
		<p>Single click to enter configuration menu</p>
		<p>Turn the wheel until  appears</p>
		<p>Single click to enter menu</p>

		<p>Turn the wheel until  appears</p>
		<p>Confirm,  is blinking</p> <p>Then the display will return to </p>
		<p>Keep pressed until esc to main</p>
		

6.13.6.3.2 Memorize the push buttons to the receiver

DISPLAY STATUS	ACTION	DESCRIPTION
		Single Click, enter programming menu
		Single click to enter configuration menu
		Single click to enter INPUTS menu (it can display a number from 0 to 63). Single click the wheel once the correct input is visualized In. 0 In.1 In.2 In.63
		Turn the wheel until you reach the desired input to memorize according to the table in the next section. For example, a button on the ground landing, arrow up:
		Single click to enter programming mode

		<p>Selection of the device type, rotate wheel until type of device is:</p> 
	 <p>Single click</p>	<p>Single click to enter into teaching mode</p>
	 <p>Single click</p>	<p>"t" is displayed. Single click to start teaching</p>
		<p>"t" is blinking, proceed to tech: Press the button to be memorized 3 times.</p> <p>t1 is displayed after the first press t2 is displayed after the second press t3 is displayed quickly after the third press</p>
		<p>The display will visualize the input memorized with the "_" signifying the push button is memorized.</p>

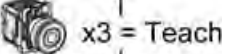
		<p>Turn the wheel until you reach the next input to be memorized "1 1"</p>  = ENT Single click     = ENT Single click   = ENT Single click   x3 = Teach <p>Memorized. Continue for all push buttons to be memorized.</p>
---	---	---

6.13.6.3.3 Push button programming table



0 = Button 0 Arrow up	20= Button 10 Arrow up	40= Button 20 Arrow up
1 = Button 1 Arrow down	21= Button 11 Arrow down	41= Button 21 Arrow down
2 = Button 1 Arrow up	22= Button 11 Arrow up	42= Button 21 Arrow up
3 = Button 2 Arrow down	23= Button 12 Arrow down	43= Button 22 Arrow down
4 = Button 2 Arrow up	24= Button 12 Arrow up	44= Button 22 Arrow up
5 = Button 3 Arrow down	25= Button 13 Arrow down	45= Button 23 Arrow down
6 = Button 3 Arrow up	26= Button 13 Arrow up	46= Button 23 Arrow up
7 = Button 4 Arrow down	27= Button 14 Arrow down	47= Button 24 Arrow down
8 = Button 4 Arrow up	28= Button 14 Arrow up	48= Button 24 Arrow up
9 = Button 5 Arrow down	29= Button 15 Arrow down	49= Button 25 Arrow down
10= Button 5 Arrow up	30= Button 15 Arrow up	50= Button 25 Arrow up
11= Button 6 Arrow down	31= Button 16 Arrow down	51= Button 26 Arrow down
12= Button 6 Arrow up	32= Button 16 Arrow up	52= Button 26 Arrow up
13= Button 7 Arrow down	33= Button 17 Arrow down	53= Button 27 Arrow down
14= Button 7 Arrow up	34= Button 17 Arrow up	54= Button 27 Arrow up
15= Button 8 Arrow down	35= Button 18 Arrow down	55= Button 28 Arrow down
16= Button 8 Arrow up	36= Button 18 Arrow up	56= Button 28 Arrow up
17= Button 9 Arrow down	37= Button 19 Arrow down	57= Button 29 Arrow down
18= Button 9 Arrow up	38= Button 19 Arrow up	58= Button 29 Arrow up
19= Button 10 Arrow down	39= Button 20 Arrow down	59= Button 30 Arrow down

Example:

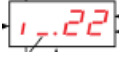
Button on 0 ground level, arrow up must be programmed in 

Button on the 11th level, arrow up must be programmed in 

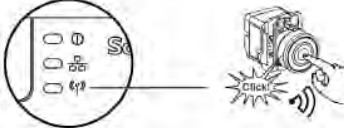
6.13.6.3.4 Testing push buttons

		<p>Press one button at a time:</p>  <p>The antenna LED (Yellow) will blink and the display will visualize the input number for the button.</p>
	 <p>FLOOR 7 DOWN</p>	<p>EXAMPLE: If you press the down arrow button on the 7th floor, the display will visualize i_13</p>

ATTENTION:

When the hoist stops at the floor to be serviced, open the door within 5 seconds. If you do not open the door within 5 seconds the hoist will continue to the next booking.

ATTENTION:

The hoist can be called to the ground level by utilizing the “Call to Ground” button located on either the onboard controls or base level controls.



6.14 MOUNTING THE DOORS

6.14.1 Mounting the sliding doors

Proceed as follows:

- the door (1) is supplied fully assembled and equipped with electrical and mechanical interlock system for installation safety and safe passage of materials and persons
- people involved in the installation must exclusively position and fix the gate to the existing structure
- to connect to traditional scaffolding or cantilever, place the door and fasten the supporting rods (2) by means of perpendicular clamps
- execute the electrical connections of all landing equipment

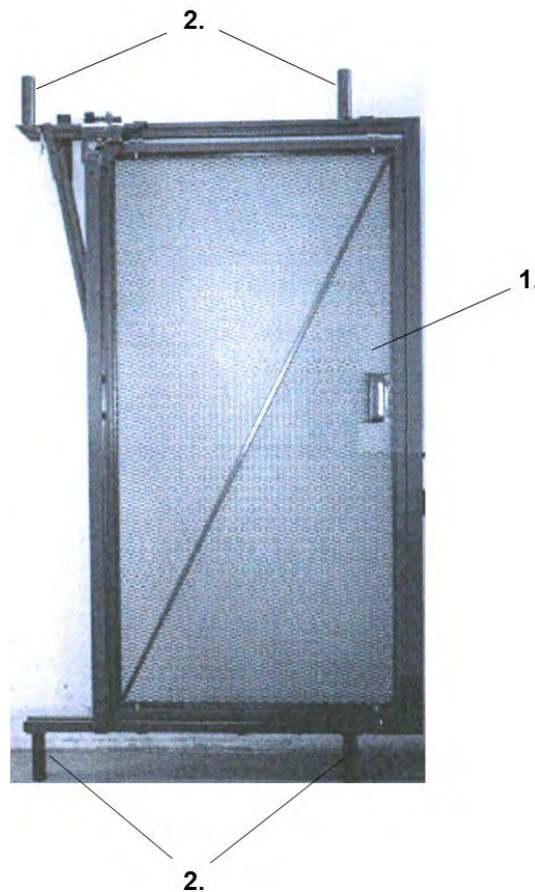
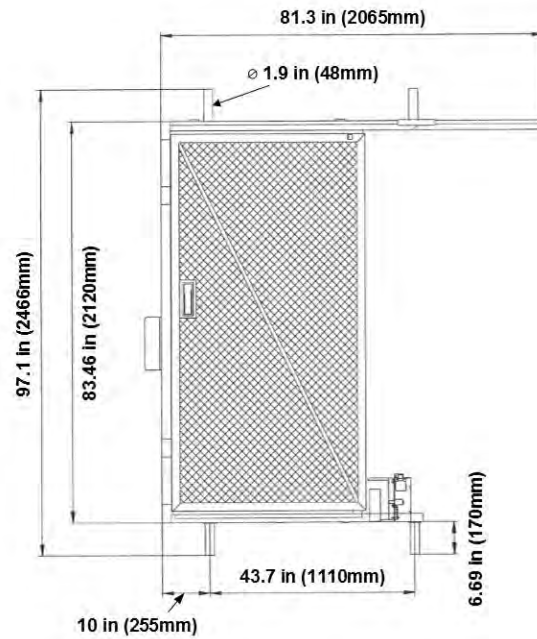
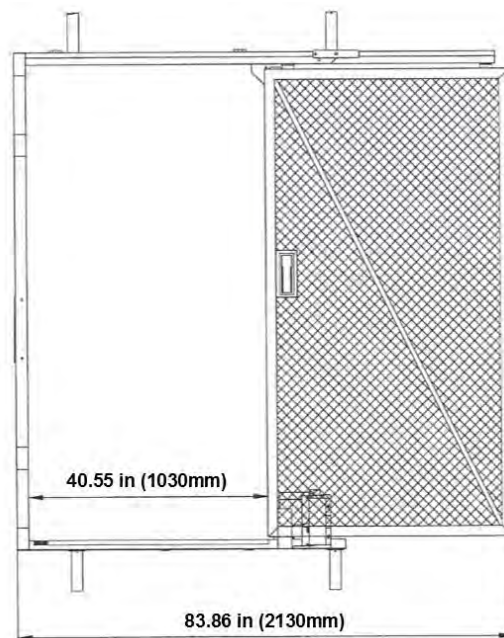

Figure 6.19



Closed Door - Hostway View

Figure 6.20



Open Door – Hostway View

Figure 6.21

Landing gates are available with the opening from right to left or left to right (with optional conversion kit).

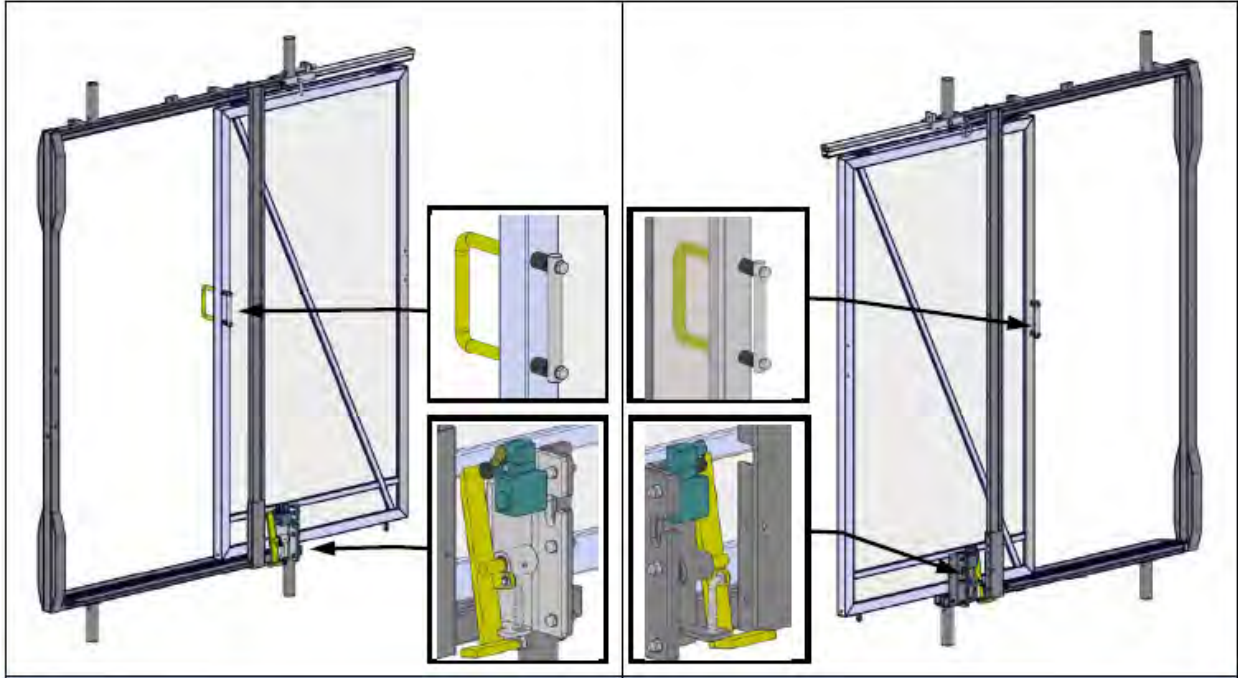

Figure 6.22

Example of installation:

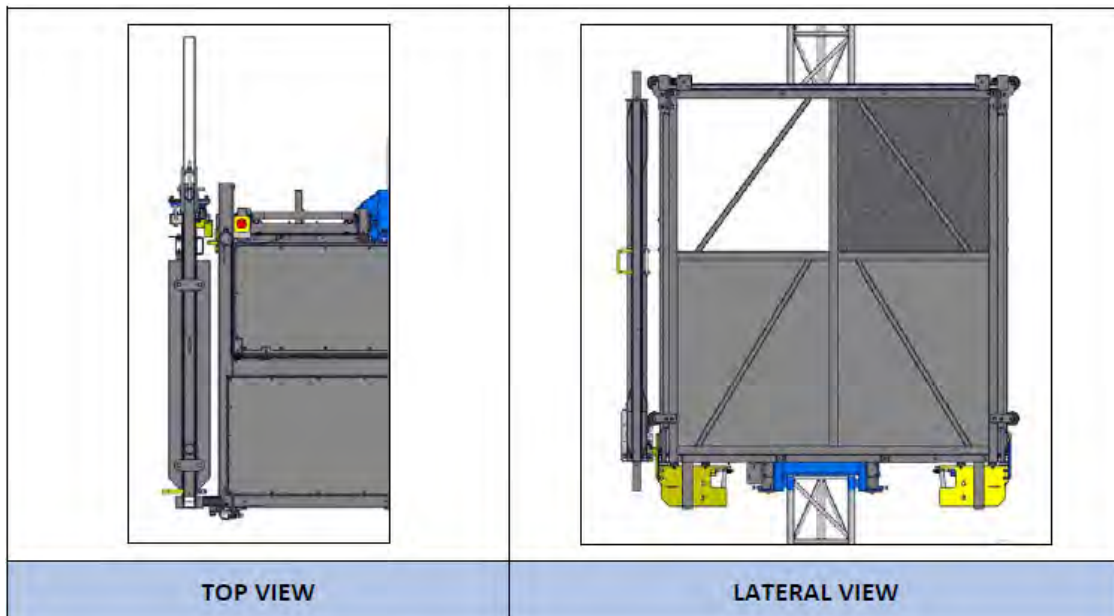

Figure 6.23

6.15 GROUND ENCLOSURE ASSEMBLY

The MC2000PMB V comes with a full height ground enclosure. ANSI/ASSP A 10.4 requires a base enclosure to prevent personnel or materials from entering the hoistway. The ground enclosure comes equipped with a sliding door whose position is monitored by a limit switch. The limit switch must be connected to the ground controls station.

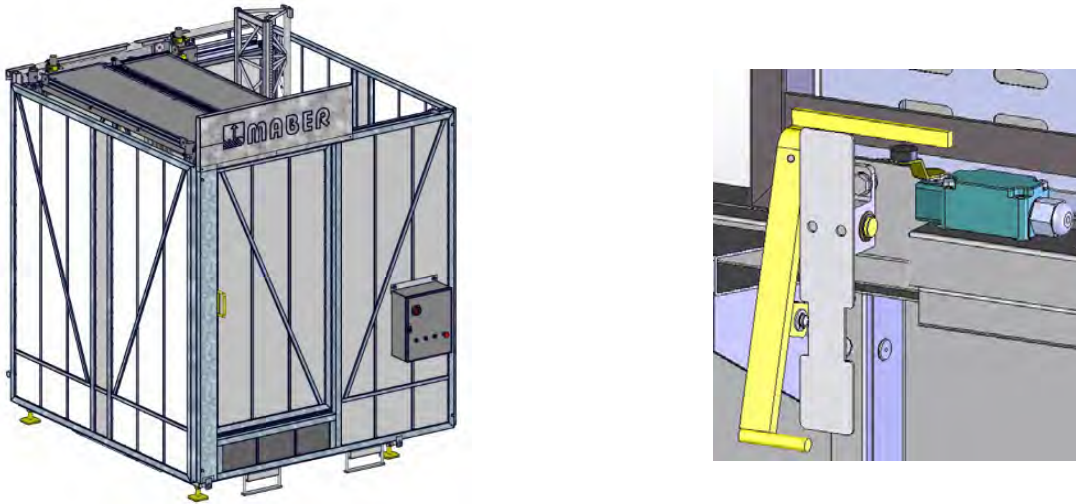

Figure 6.24

6.15.1 Ground enclosure extension for 700mm drum

The 700mm drum must be utilized for trailing cable lengths exceeding 150ft. The ground enclosure must be extended to facilitate the use of this drum. The components below are necessary for this operation:

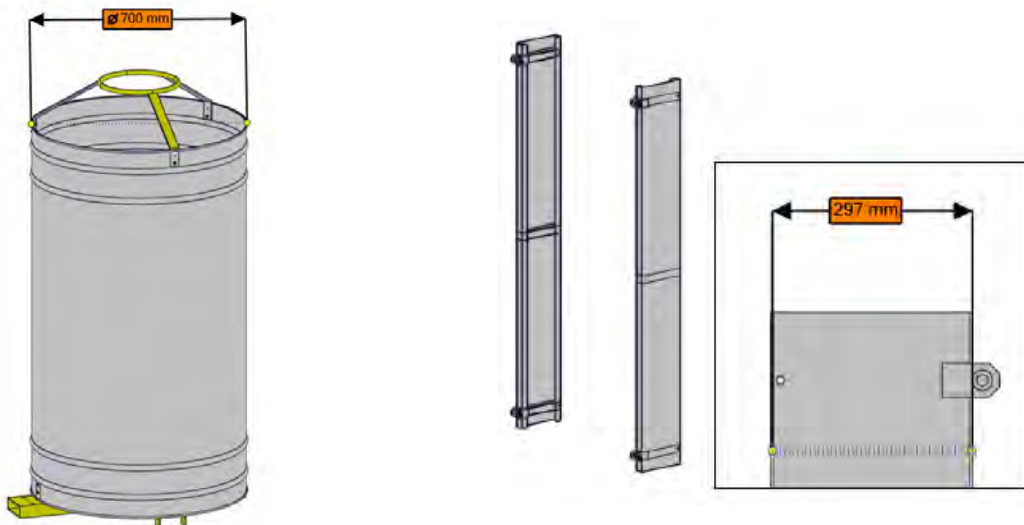

Figure 6.25

Remove the rear base enclosure panel and skirt. Install the extension pieces and reattach the back panels as depicted below:



Figure 6.26

Base enclosure with extensions installed:



Figure 6.27

This page has been left blank for formatting purposes

CHAPTER 7: COMMAND AND CONTROL DEVICES

Record of modifications

Revision	Executor	Date	Description of modification

7 COMMAND AND CONTROL DEVICES

7.1 GENERAL INFORMATION ON COMMAND DEVICES

The command devices installed on the control panels allow the operators to carry out their duty by commanding the machine's entire cycle of operations in optimal conditions.

The machines can be commanded in different ways at different locations depending on local regulations.

The Personnel hoist machines, intended to transport persons and material have control panels on the base unit and onboard the machine, floor level calling control panels, and the control panel to test the safety brake device.

ATTENTION:

On the machines after setting the FLOOR TO REACH by using the INCREASE FLOOR pushbutton or the DECREASE FLOOR pushbutton, pressing and holding the RUN/OPERATOR pushbutton, the loading UNIT will move to the desired floor location. If a floor location is needed to be stopped at before reaching the FLOOR TO REACH location, press the STOP NEXT FLOOR pushbutton. The loading UNIT will stop when it reaches the next floor. If alignment with the building's floor level needs to be improved, you will need to re-program the floor location.

ATTENTION:

AT both the top and bottom extreme ends of the path, the machine will stop automatically even if the drive button is kept pressed, since appropriate braking cams are installed on the mast.

The commands pertaining to the machine referred to in this manual are described in detail in the following paragraphs, therefore, it is of utmost importance to read this chapter attentively in order to use all the commands described correctly.

7.2 COMMANDS ON THE BASE CONTROL PANEL

With reference to figure 7.1, the electrical base control panel includes:

- C. Main switch**
- 1. UP pushbutton**
- 2. DOWN pushbutton**
- 3. STOP NEXT LANDING pushbutton**
- 4. SEND TO FLOOR pushbutton**
- 5. SEND TO GROUND pushbutton**
- 6. EMERGENCY pushbutton**



Figure 7.1

7.2.1 Main switch

The main switch with the safety lock locks in the zero position. It is placed on the electrical power control panel and allows you to interrupt the power supply to the machine. With the safety lock mechanism, the switch prevents the control panel from being opened during normal operation, therefore, not allowing operations to be carried out to the internal part of the control panel with live wiring. Moreover, the mechanism makes it possible to safely shut down the machine for all maintenance operations to be carried out, by setting the safety lock in the zero position.

7.2.2 FLOOR SELECTOR pushbutton

In “NORMAL” mode and with the machine in motion allows the operator to reserve the stop at the floor level towards which the machine is moving. This function is applicable for both upward and downward movements of the machine.

7.2.3 DOWN TO GROUND pushbutton

In “NORMAL” mode, the DOWN TO GROUND pushbutton will send the machine to the ground (0) floor location no matter what desired floor (FLOOR TO REACH) is set on the display.

7.2.4 UP pushbutton

The UP pushbutton allows the operator to move the machine towards the upper floors.

7.2.5 DOWN pushbutton

The DOWN pushbutton allows the operator to move the machine towards the lower floors.

7.2.6 STOP NEXT FLOOR pushbutton

The STOP NEXT FLOOR pushbutton allows the operator to reserve the stop at the floor level towards which the machine is moving. This function is applicable for both upward and downward movements of the machine.

7.2.7 EMERGENCY pushbutton

This is a safety device and once it is pressed, the supply voltage of the main contactor of the electrical control panel is interrupted. The operator can intentionally rotate the same button in the same direction of the arrows in order to enable to the restore system. This operation prevents the restore of the system from being enabled by mistake which would put the operator at risk.

7.2.8 Plug for TRAILING CABLE

The connector connects the ground box to the cabin box.

7.2.9 Plug for AUXILLARY SAFETY SWITCH

The connector allows the connection of additional safety devices which are installed on the access zone of the machine.

7.2.10 Plug for GROUND GATE

The connector connects the ground gate to the ground box. This is a safety device that once the ground gate is opened the supply voltage of the main contactor of the electrical control panel is interrupted.

7.2.11 Plug for FLOOR CALL BOXES

The connector allows the operator to control the machine from the landing floor levels.

7.3 COMMANDS ON THE ONBOARD CONTROL PANEL

With reference to figure 7.2, the onboard control panel includes:

- A. Main switch
 - 1. Machine mode key switch (ERECTION / PROGRAMMING / NORMAL)
 - 2. Display screen
 - 3. SEND TO GROUND pushbutton
 - 4. SEND TO SELECTED FLOOR pushbutton
 - 5. INCREASE FLOOR pushbutton
 - 6. STOP NEXT FLOOR pushbutton
 - 7. DECREASE FLOOR pushbutton
 - 8. ALARM / ERROR RESET pushbutton
 - 9. --
 - 10. CABIN LIGHT selector switch
 - 11. EMERGENCY STOP button
 - 12. CONTROL MODE key selector (CABIN / CABIN OR GROUND)
 - 13. ALARM pushbutton
 - 14. --

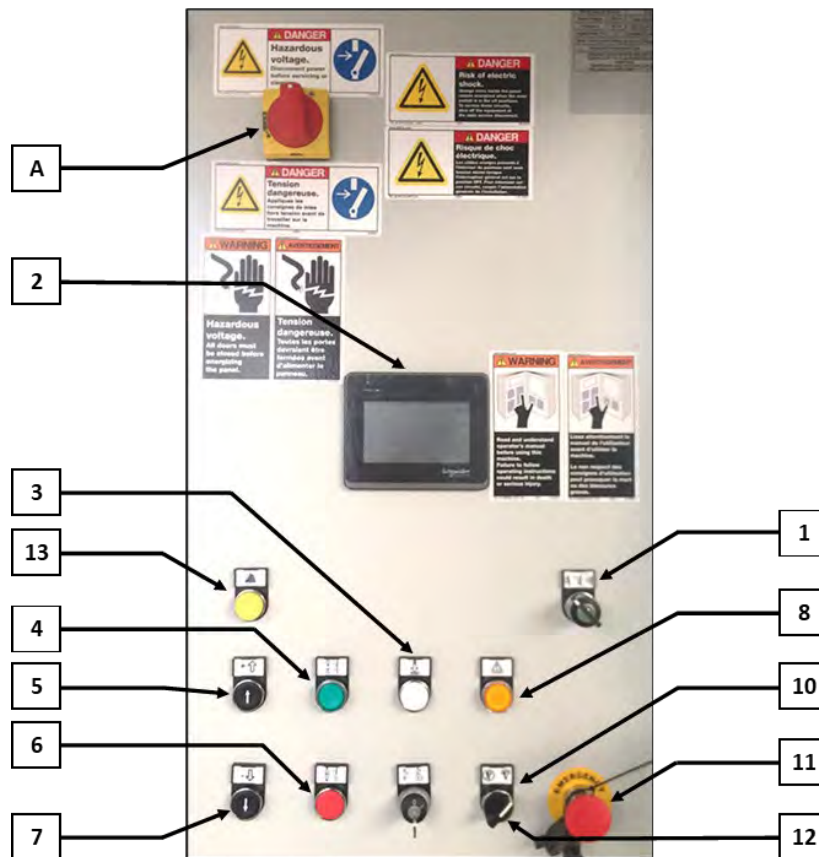

Figure 7.2

7.3.1 Main switch

The main switch with the safety lock locks in the zero position. It is placed on the electrical power control panel and allows you to interrupt the power supply to the machine. With the safety lock mechanism, the switch prevents the control panel from being opened during normal operation, therefore, not allowing operations to be carried out to the internal part of the control panel with live wiring. Moreover, the mechanism makes it possible to safely shutdown the machine for all maintenance operations to be carried out, by setting the safety lock in the zero position.

7.3.2 Machine mode key switch (ERECTION / PROGRAMMING / NORMAL)

The three-way key selector (ERECTION / PROGRAMMING / NORMAL) allows the operator to select one of the three working conditions according to the operations that are to be carried out on the machine. If the selector is rotated in “ERECTION” position, the machine is set to allow the operations of installation, dismantle, and inspection. If the selector is rotated to “PROGRAMMING” position, the machine is set to allow the addition or removal of floor level locations and cabin door locking functions. And if the selector is rotated in “NORMAL” position, the machine is set to allow normal operations.

7.3.3 Plug for AUXILARY POWER

This is an industrial type of socket for tools with a safety lock. It is a convenient accessory to have as it allows you to supply power to a transformer to power small, handheld electric tools such as drills, grinding machines, demolition hammers, small air compressors etc. It is essential during the assembly stages in order to avoid having dangerous cable extensions dangling from the loading unit.

7.3.4 SIREN / ALARM pushbutton

The SIREN/ALARM pushbutton allows the operator to activate an acoustic warning alarm.

7.3.5 DISPLAY screen

The DISPLAY screen is a visual display to the installers, technicians, or operators the status of the unit. The DISPLAY screen can show the mode of the machine, the hours of work, level location of machine, desired floor level, programming instructions, and error codes for troubleshooting repairs to the machine. The DISPLAY screen can be changed to display in different languages. The DISPLAY screen has function buttons used during “PROGRAMMING” mode for selecting the various door locking functions.

7.3.6 INCREASE FLOOR pushbutton

The INCREASE FLOOR pushbutton is used during “ERECTION” mode to move the machine in to upward travel. In “PROGRAMMING” mode, it is used to assign a floor number on the DISPLAY to the location of the machine. And in “NORMAL” mode, it is used to increase the floor number on the DISPLAY to the desired floor level.

7.3.7 DECREASE FLOOR pushbutton

The DECREASE FLOOR pushbutton is used during “ERECTION” mode to move the machine in to downward travel. In “PROGRAMMING” mode, it is used to assign a floor number on the DISPLAY to the location of the machine. And in “NORMAL” mode, it is used to decrease the floor number on the DISPLAY to the desired floor level.

7.3.8 RUN / OPERATOR pushbutton

The RUN / OPERATOR pushbutton is used during “PROGRAMMING” mode to set the desired floor number and desired machine height into program memory. In “NORMAL” mode, it is used to run/operate the machine to the desired floor selected (FLOOR TO REACH).

7.3.9 STOP NEXT FLOOR pushbutton

The STOP NEXT FLOOR pushbutton pressed for a few seconds without machine movement in “ERECTION” mode or “NORMAL” mode will display the total hours of work. In “NORMAL” mode and with the machine in motion allows the operator to reserve the stop at the floor level towards which the machine is moving. This function is applicable for both upward and downward movements of the machine.

7.3.10 SEND TO GROUND pushbutton

The SEND TO GROUND pushbutton in “PROGRAMMING” mode pressed for more than 10 seconds will erase all floor locations out of the program memory. In “NORMAL” mode, it will send the machine to the ground (0) floor location no matter what desired floor (FLOOR TO REACH) is set on the display.

7.3.11 Control mode key switch (CABIN ONLY / CABIN & GROUND)

The two-way key selector (CABIN ONLY/CABIN & GROUND) allows the operator to select one of the two operation conditions. If the selector is rotated in “CABIN ONLY” position, the machine is set to allow the operations of controlling the machine in the cabin only. If the selector is rotated in “CABIN & GROUND” position, the machine is set to allow the operations of controlling the machine in the cabin, at the ground location, or at the floor level locations. In “CABIN & GROUND”, the cabin has priority of the control functions over the other controlling locations.

7.3.12 ALARM / ERROR RESET pushbutton

The ALARM / ERROR RESET pushbutton is used to reset the alarms shown in the DISPLAY screen after the error has been corrected.

7.3.13 AUTOMATIC GREASER key switch (OFF/ON)

The key selector activates the automatic greaser. The automatic greaser only runs during the up direction of the machine.

7.3.14 CABIN LIGHT key switch (OFF/ON)

The key selector activates the cabin light.

7.3.15 Signal light POWER

The POWER signal light indicates that the onboard control panel is powered.

7.3.16 EMERGENCY pushbutton

This is a safety device and once it is pressed, the supply voltage of the main contactor of the electrical control panel is interrupted. The operator can intentionally rotate the same button in the same direction of the arrows in order to enable the restore system. This operation prevents the restore of the system from being enabled by mistake which would put the operator at risk.

7.3.17 OVERWEIGHT SENSOR controller

The OVERWEIGHT SENSOR controller is the CPU of the overweight system. The controller receives signals from the overweight sensors and compares the readings to the calibrated weights. If the readings are outside the range of the full load rating the OVERWEIGHT SENSOR controller interrupts the control voltage of the main contactor, in turn interrupting the supply power.

7.3.18 Plug for DROP TEST PENDANT

The multi-pin connector with ten pins allows the drop test keyboard to be connected, which allows the safety brake system to be tested, which is obligatory upon every installation.

7.3.19 Plug for TRAILING CABLE

The connector connecting the ground box to the cabin box.

7.4 DISPLAY SCREEN CONTROLS

7.4.1 Display when operating from inside the cabin

When the “**WORKING MODES**” key selector is in pos. “3” for “**Normal use**” and the **Procedure verification** has been completed, the display will show:



- S1. Range for lifting:** The upper part indicates the max floor that can be reached while the lower part indicates the lowest floor that can be reached. The arrows indicate the direction of machine run.
- S2. Actual floor:** This indicates where the machine is currently (if machine is in between floor 0 and floor 1, the display will indicate 0).
- S3. Destination floor:** Use arrows (pos. 5&7 in figure 7.2) or press directly on the number on the display. Destination can be modified when the hoist stops and is “FREE”.
- S4 Machine speed:** Effective speed (meters/minute).
- S5 Machine load:** Load inside the cage (kg).
- S6 Line voltage:** Voltage of the power supply (Volts)
- S7 Motor current:** Current absorption of motor (Ampere).
- S8 Lubrication alarm:** Lubricating pump warning light when pump not activated or grease level has reached minimum levels (when equipped).
- S9 Machine use:** When the machine is BUSY or at a floor for the time specified in the “lead-time parameter set”, it becomes FREE. Message will be:



7.4.2 Display when operating from Ground controls

While controlling the hoist from outside the cabin (see section), the display will show:



7.4.3 Setting the floor of destination

Selecting the destination floor is only possible when the machine is **FREE**.

	<p>Select the “Floor to store” with the arrows:</p> <p>“UP”</p> <p>At each press, the value increases of one digit. Keep it pressed for quicker increase.</p> <p>“DOWN”</p> <p>At each press, the value decreases of one digit. Keep it pressed to decrease the value quickly.</p>
--	---

7.4.4 Move the machine to selected destination

After destination selection, the machine can be run using the below:

	<p>“SEND TO FLOOR”</p> <p>Press and hold to run the machine to the desired destination previously set and visualized on the display.</p>
	<p>“STOP NEXT LANDING”</p> <p>Press this button with machine in movement.</p> <p>ONCE THIS FONCTION ACTIVATED, the hoist will stop to the next floor. except if it is too close to this level, in this case it will stop to next floor. The display will show “STOP NEXT” confirming the function has been activated.</p> <div data-bbox="792 1801 1057 1864" style="text-align: center;"> </div>

7.5 COMMANDS FOR FLOOR CALL BOXES

With reference to figure 7.3, the keyboard includes:

1. **UP pushbutton**
2. **DOWN pushbutton**
3. **STOP NEXT FLOOR pushbutton**
4. **EMERGENCY pushbutton**
5. **Plug for FLOOR CALL BOXES**

7.5.1 UP pushbutton

The UP pushbutton allows the operator to move the machine towards the upper floors.

7.5.2 DOWN pushbutton

The DOWN pushbutton allows the operator to move the machine towards the lower floors.

7.5.3 STOP NEXT FLOOR pushbutton

The STOP NEXT FLOOR pushbutton allows the operator to reserve the stop at the floor level towards which the machine is moving. This function is applicable for both upward and downward movements of the machine.

7.5.4 EMERGENCY pushbutton

This is a safety device and once it is pressed, the supply voltage of the main contactor of the electrical control panel is interrupted. The operator can intentionally rotate the same button in the same direction of the arrows in order to enable the restore system. This operation prevents the restoration of the system from being enabled by mistake which would put the operator at risk.

7.5.5 Plug for FLOOR CALL BOXES

The connector allows you to connect the floor call box with the machine's control system.



Figure 7.3

7.6 COMMANDS FOR WIRELESS CALL STATION

The wireless call station is an optional feature that when installed, allows for selective collective or operator monitored call operation. With reference to figure 7.4 the keyboard includes:

1. **UP pushbutton**
2. **DOWN pushbutton**



Figure 7.4

7.6.1 Up button

The UP button activates the call for the landing the button is assigned. The command is placed in the queue for either the system or the operator to decide when to act, depending on the parameters set during installation.

7.6.2 Down button

The DOWN button activates the call for the landing the button is assigned. The command is placed into the queue for either the system or the operator to decide when to act, depending on the parameters set during installation.

7.7 COMMANDS ON THE DROP TEST PENDANT

With reference to figure 7.5, the keyboard includes:

1. **UP** pushbutton
2. **TEST** pushbutton
3. **EMERGENCY** pushbutton

7.7.1 UP pushbutton

The UP pushbutton allows the operator to move the machine towards the upper floors.

7.7.2 TEST pushbutton

The TEST pushbutton allows a qualified operator to carry out the test on the safety brake device. The test allows you to ensure that the safety brake system functions perfectly. After every test, the intervention system must be restored by following the instructions given in the relative paragraph.

WARNING:

This button opens the motor brakes, causing the free fall of the machine therefore must be pressed only by a qualified operator.

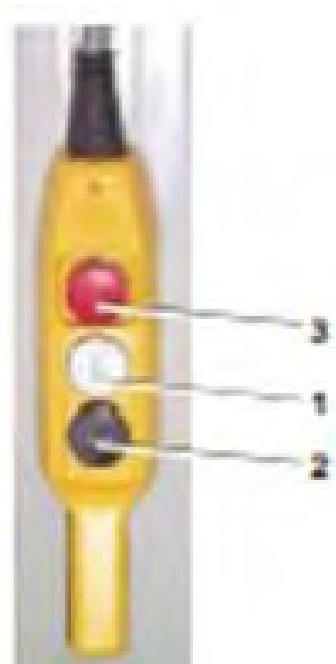

Figure 7.5

7.7.3 EMERGENCY pushbutton

This is a safety device and once it is pressed, the supply voltage of the main contactor of the electrical control panel is interrupted. The operator can intentionally rotate the same button in the same direction of the arrows in order to enable the restore system. This operation prevents the restoration of the system from being enabled by mistake which would put the operator at risk.

DANGER:

The operator is authorized to exclusively carry out the restore operations as described in the relevant paragraph. NO INTERVENTION MUST BE IMPLEMENTED ON THE SAFETY BRAKE DEVICE. Such interventions are the exclusive responsibility of BETA MAX Technical Support.

This page has been left blank for formatting purposes

CHAPTER 8: SAFETY REGULATIONS

Record of modifications

Revision	Executor	Date	Description of modification

8 SAFETY REGULATIONS

8.1 DESCRIPTION OF THE MACHINE'S SAFETY SYSTEMS

The machine is equipped with effective safety systems. The loading unit (1) intended for transporting persons and materials, is a completely enclosed structure equipped with access doors (2) which interlock both mechanically and electrically. The area surrounding the machine is completely protected with the base enclosure (3), which prevents access in any condition as it also has an interlocking access door.

DANGER:

It is absolutely forbidden to operate the machine without the above-mentioned protection devices in place. It is absolutely forbidden to replace the protection devices with others, which do not meet the requirements of safety legislation. Such implementations could cause considerable injuries and damage the mechanical components.



Figure 8.1

8.2 MOVABLE GUARDS

Aluminum panels or doors made of steel bars and aluminum mesh are set in place to close off parts of the machine used to transport persons and materials, or areas which can be particularly dangerous due to the machine's movable parts or to an area where electricity passes. The machine is equipped with movable guards for the access door of the base enclosure and for that of the loading unit; these are controlled electrically and interlock mechanically as well as movable guards for the electrical control panels, which lock with a key.

8.2.1 Electrically controlled and mechanical interlocking movable guards

The electrically controlled movable guards that interlock mechanically are applied to the base enclosure access door, the ground floor access door to the loading unit and the doors leading to the floor level landing platforms. The control system consists of position detection switches and the mechanical interlocking system. If the door is open or not closed properly, the switch is not pressed; therefore, the machine cannot be operated. If the loading unit and the floor level doors are not aligned correctly, the mechanical interlocks prevent the doors from being opened. The base enclosure doors and the platform doors are shown in figure 8.2; the door (1) allows access to the base enclosure and the platform doors (2) allows access to the loading unit.

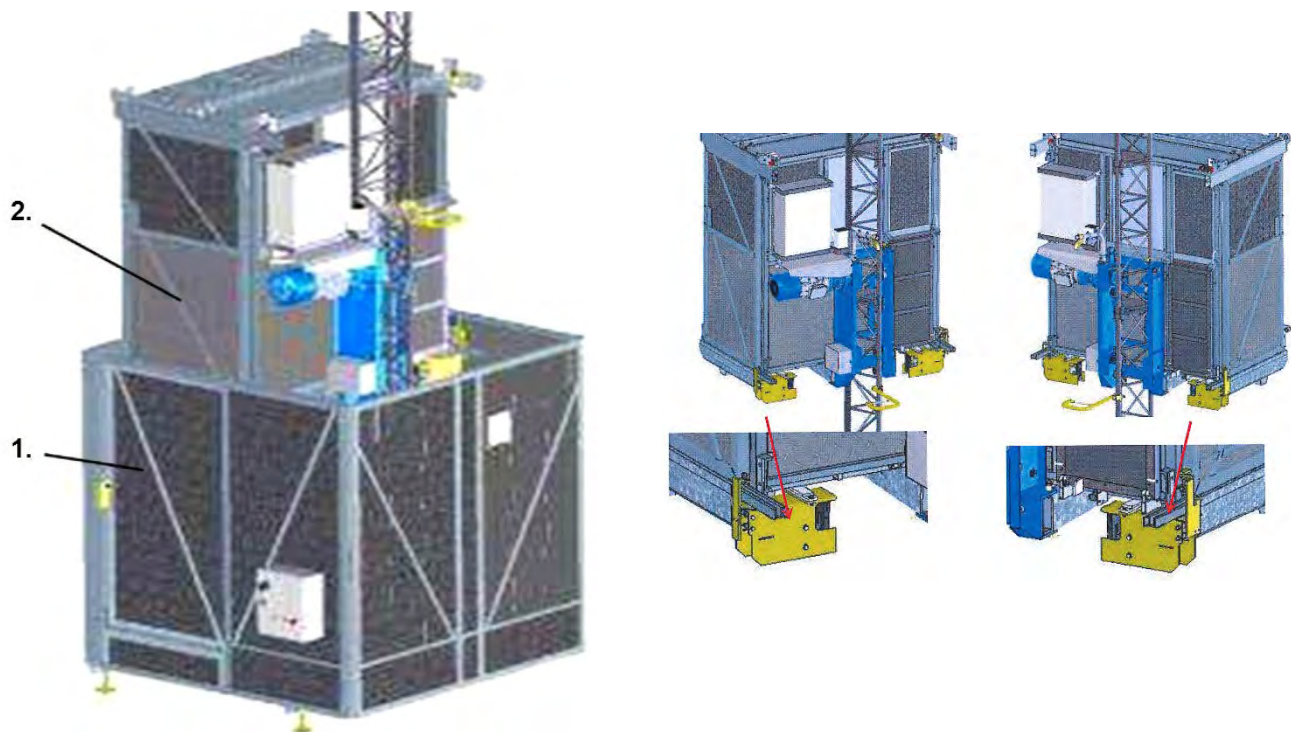

Figure 8.2

8.2.2 Electrically controlled movable guards

The electrically controlled movable guards consist of protection bars placed close to platform used for mounting the wall anchors, the roof hatch, and the mast guard.

The guards are shown in figure 8.3; the movable bar (1) is the upper guard of platform used for assembling the wall anchors, the roof hatch (2), and the mast guard (3).

ATTENTION:

It is strictly forbidden to work with the movable guards open, by-passing the switches control. If the machine is deprived of the safety electrical controls or the same controls are replaced with others which are not original and not adequate, BETA MAX disclaims all responsibility for damage caused to the machine and injuries caused to persons.

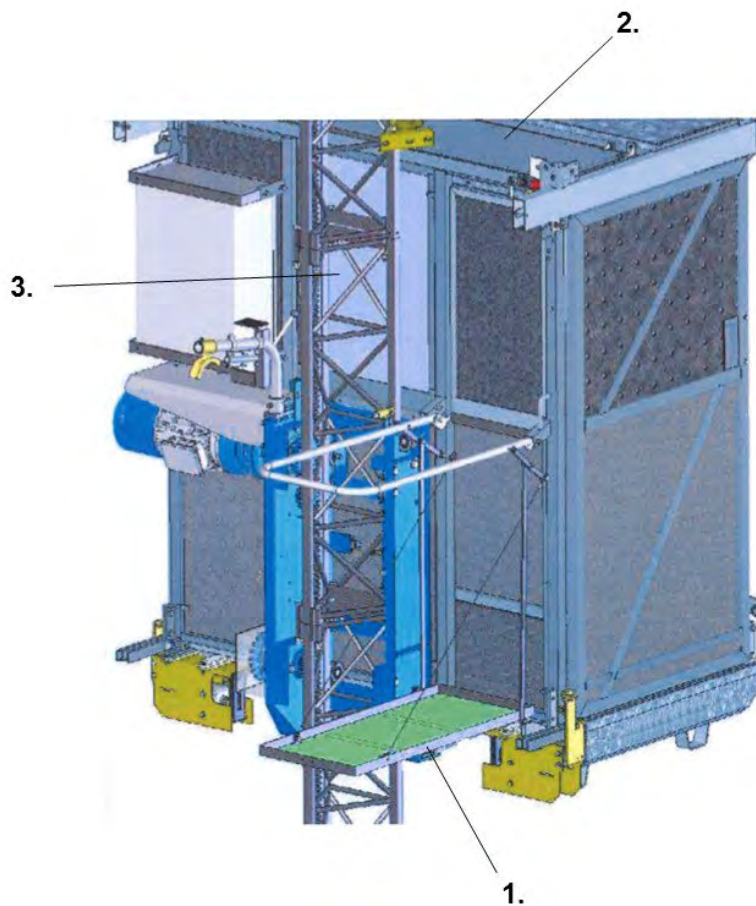

Figure 8.3

8.2.3 Movable guards which lock with a key or tool

The movable guards which lock with a key or tool are applied to the panels used to close the electrical base control panel and that are found onboard the machine. The locking slot is used for the base control panel and for the onboard control panel. The main switch (2) on the electrical base control and the onboard control panel can be locked in the “OFF” position.

DANGER:

Before accessing the internal parts of the electrical control panels, wait at least 15 minutes after the machine is switched off, so that some internal electrical components can dispel any dangerous residual energy they may have.

DANGER:

The locking keys must never be left in the control panels when the machine is in normal operation but must be safely kept by the technical maintenance personnel or by the specialized expert who has been designated to carry out any electrical operations.

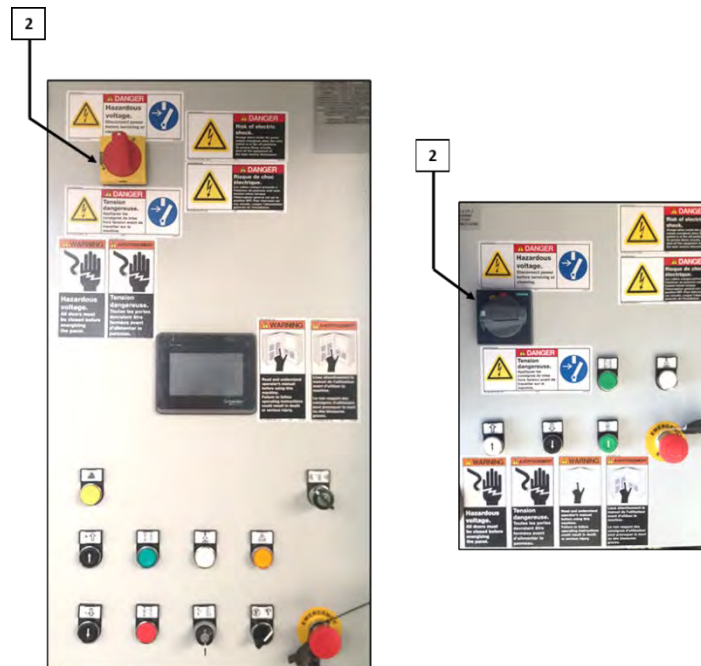

Figure 8.4

8.3 FIXED GUARDS

Structures made of steel rods and bars and metal sheets are placed to protect some areas of the loading unit, where are not present the access ramps or where are particularly dangerous areas of the machine which allow access to areas reserved for personnel responsible for carrying out installation and maintenance operations, and the areas where machine's members are in motion.

The main fixed guards are listed below:

1. closing panels of the loading unit
2. closing panel of the erection platform
3. cover onto the gear motor pinion (there can be more than one device)
4. cover onto the parachute (safety device)
5. cover onto the parachute (safety device) pinion (it can be welded onto the support)

DANGER:

The machine must NEVER be started up and used without the fixed guards being properly installed. All the fixed guards must ALWAYS be installed before the platform is elevated and the installation operations begin.

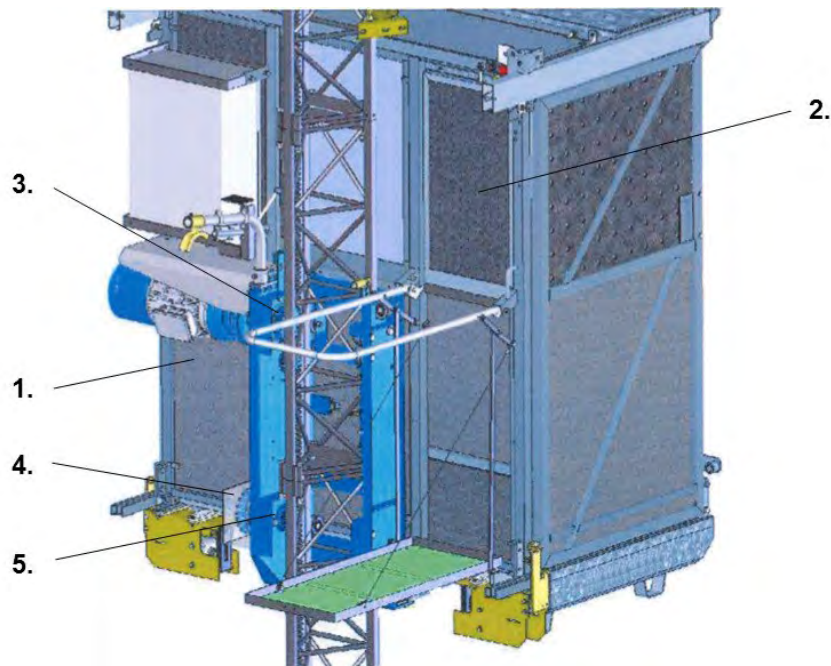

Figure 8.5

8.4 SAFETY EQUIPMENT

The machine is supplied with the following safety equipment:

- mechanical equipment
- electro-mechanical equipment
- electrical equipment
- overload control device

8.4.1 Mechanical equipment

The following mechanical safety devices are installed on the machine:

- safety hooks on the lifting unit
- spring shock absorbers on the base unit

The safety hooks are welded on the lifting unit in order to prevent the unit from coming off the mast, should the operator inadvertently drive the machine beyond the end of the vertical mast whilst lifting the cabin upwards. These hooks keep the lifting unit hooked to the vertical mast. The spring shock absorbers are mounted on the base unit in order to cushion the metal contact between the loading unit and the base unit in the event of an incorrect maneuver implemented by the operator, or if the loading unit free-falls. With reference to modest impacts, these spring buffers will prevent damaging the loading unit and the base unit.

8.4.2 Electro-mechanical equipment

The following electromechanical safety devices are installed on the machine:

- safety brake device with progressive braking
- mechanical and electrical interlock on the platform doors
- mechanical and electrical interlock on the base enclosure door
- safety cam on the platform used for assembly operations
- mechanical and electrical interlock on the roof hatch

The safety brake is a safety device, which intervenes and stops steadily the loading unit, if it descends with an excessive speed. Moreover, the safety brake device is equipped with a switch that indicates intervention by interrupting the main contactor. Therefore, it will not be possible to put the machine back on until the cause which provoked the intervention is identified and resolved.

The electrical and mechanical interlocking devices found on the platform doors and on the base enclosure door prevent the doors from being opened if the machine is not at a standstill and in the correct position for access; obviously, if the doors are open, the electrical devices prevent the machine from moving.

The safety cams on the platform used for assembly operations prevent the machine from moving unless these are properly closed.

The mechanical and electrical interlock device on the roof hatch prevents the machine from moving unless it is properly closed.

8.4.3 Electrical equipment

On the machine are identifiable service and security switches. Service switches are the normal switch for the ascent and descent. The switches that concern the safety of the loading unit are:

- switch for upward over-travel
- switch for downward over-travel
- safety switch on the access doors on the loading unit
- safety switch on the access door locks on the loading unit
- safety switch on the cam of the platform used for assembly operations
- mast presence switch

Moreover, a normally closed contact EMERGENCY push button is found on the machine.

SWITCH FOR UPWARD OVERTRAVEL

The upward over-travel device consists of a switch with a small wheel and the upper over-travel pad, which is installed on the top safety mast. The switch intervenes by interrupting the 24 V control circuit, which in turn intervenes on the main contactor. This device can be reset in the following way:

- acting upon the manual brake release, which is placed on the motor and moving slightly downwards.

SWITCH FOR DOWNWARD OVERTRAVEL

The downward over-travel device consists of a switch with a small wheel and the downward over-travel pad that is placed in a lower position from the downward end-of-travel pad. This device intervenes:

- in the event of the downward switch breaking or malfunctioning
- if the loading unit, even slightly, after the downward braking pad stops it. Therefore, the device is also an indicator of the wear and tear of the gear motor brakes and also of excessive load on the machine
- in the event of failure in voltage when descending, in an emergency; by means of the manual brake releases, the machine is stopped on the spring absorbers of the base unit
- in the event of the three-phase circuit being inverted (phase failure) resulting in the machine moving in the opposite direction (upward-downward) to that implemented on the control panel

The downward over-travel switch intervenes by interrupting the 24 V control circuit, which in turn intervenes on the main contactor.

The reset of the device can be done by plugging in the drop test pendant and driving the unit up off the downward over-travel pad.

SAFETY SWITCH ON THE ACCESS DOORS OF THE LOADING UNIT

The safety switch on each access door is positioned on the vertical support of the loading unit. If the door is opened or not properly closed, during the machine's normal operation, the switch prevents the movement of the machine.

Just like all the other devices described above, the switch intervenes by interrupting the entire 24 V control circuit, which in turn intervenes on the main contactor. The device can be reset by the closing of the access door correctly while ensuring that the head of the switch is not broken, flattened or altered in any way.

SAFETY SWITCH ON THE ACCESS DOOR LOCKS OF THE LOADING UNIT

The safety switch on each access door lock is positioned on the support bracket of the magnetic door lock at the base of each access door of the loading unit. If the door is opened, not properly closed, or unlocked during the machine's normal operation, the switch prevents the movement of the machine.

Just like all the other devices described above, the switch intervenes by interrupting the entire 24 V control circuit, which in turn intervenes on the main contactor. The device can be reset by the closing of the access door correctly and locked while ensuring that the head of the switch is not broken, flattened or altered in any way.

SAFETY SWITCH ON THE CAM OF THE PLATFORM USED FOR ASSEMBLY OPERATIONS

The safety switch on the small platform used for assembly operations prevents the machine from moving if this platform is not properly closed. Just like all the other devices described above, the switch intervenes by interrupting the entire 24 V control circuit, which in turn intervenes on the main contactor. The device can be reset by the correct closing of the access door while ensuring that the head of the switch is not broken, flattened or altered in any way and that it is placed perfectly in the center of the cam shaft.

MAST PRESENCE SWITCH

The mast presence switch is installed on the upper part of the lifting unit, preventing the movement of the machine when the group itself does not stop on the upward over-travel switch or during assembly if the machine was made up incorrectly above the last mast installed. The switch intervenes by interrupting the 24 V control circuit, which in turn intervenes on the main contactor. This device can be reset in the following way:

- acting upon the manual brake release, which is placed on the motor and moving slightly downwards.

EMERGENCY PUSHBUTTON

On the control panels supplied with the machine and at the roof level, there are clearly visible red mushroom pushbuttons used to stop the machine in case of emergency (emergency stop). Should the need arise, pressing one of these pushbuttons will interrupt the entire 24 V control circuit, which in turn intervenes on the main contactor; acting in the same way as a normal safety switch. Once pressed, this remains pressed. To restore the machine back to normal operation, at the end of the emergency, the push button has to be rotated, reconnecting its normally closed contact, which is opened by the pressure exerted when the operator presses on it.

8.4.4 Overweight control device

An overload signaling device equipped with an acoustic advisor allows the operator to check the load charged of the machine at any time. The alarm will begin to beep when the payload on the machine has exceeded 70% of the maximum payload permitted. The alarm will begin a continuous sound when the payload on the machine has exceeded the maximum payload permitted and will interrupt the entire 24 V control circuit, which in turn intervenes on the main contactor.

8.5 LIST OF PLATES FOUND ON THE MACHINE

The machine is equipped with a series of adhesive plates, which correspond to dangerous areas, in order to immediately signal dangers which the operator can face. This paragraph is intended to point out where the signs are found on the machine and explain their meaning. The signs found on the machine are:



1. **General danger.** Consult the instruction manual in case of maintenance, adjustment, particular use, etc.



2. **Danger: moving parts.** This sign indicates that there are chains, mechanisms and other working components within the guarded areas.



3. **Individual protection gear is obligatory.** These signs indicate the type of individual protection gear to use (gloves, noise protection earmuffs and safety shoes).



4. **Pinching/shearing hazard.** There is a risk of having your hands pinched/sheared, if placed close to the equipment during works in progress.



5. **Obligatory use of indicated point.** The sign indicates which points are to be used for lifting (to insert the lifter blades or the hook used for the fastening system).



6. **Risk of electric shock.** In proximity of this signal you are in presence of electric voltage and there is the danger of electric shock.

Every time the machine is installed, the site manager who is responsible for the installation, must see to applying a particular plate (included in Annexes on this manual) pertaining to the layout of the machine itself. The plate indicates the measurements of the installed machine's configuration and the maximum rated loads allowed, in relation to such a configuration. The plate must be placed inside the loading unit in such a way so as to be immediately visible by the operator.

8.5.1 Signs onboard the machine

Self-adhesive signs are placed on the machine in order to indicate dangerous points, such as where the rack and pinion fit together on the lifting unit, where there are the access ramps gears that allow its closing and in points where one needs to be aware of live parts in order to avoid contact, such as inside the electrical control panel. The figure shows the layout of such signs:

1. **Danger moving parts.** This sign (1) indicates the presence of moving parts such as chains and mechanisms for motor transmission
2. **Pinching/shearing hazard.** This sign (2) indicates that there is a risk of having your hands pinched/sheared if placed near the closures of the loading unit's access ramps
3. **Danger live parts.** This sign (3) indicates that one must be aware of live parts when opening electrical enclosures.

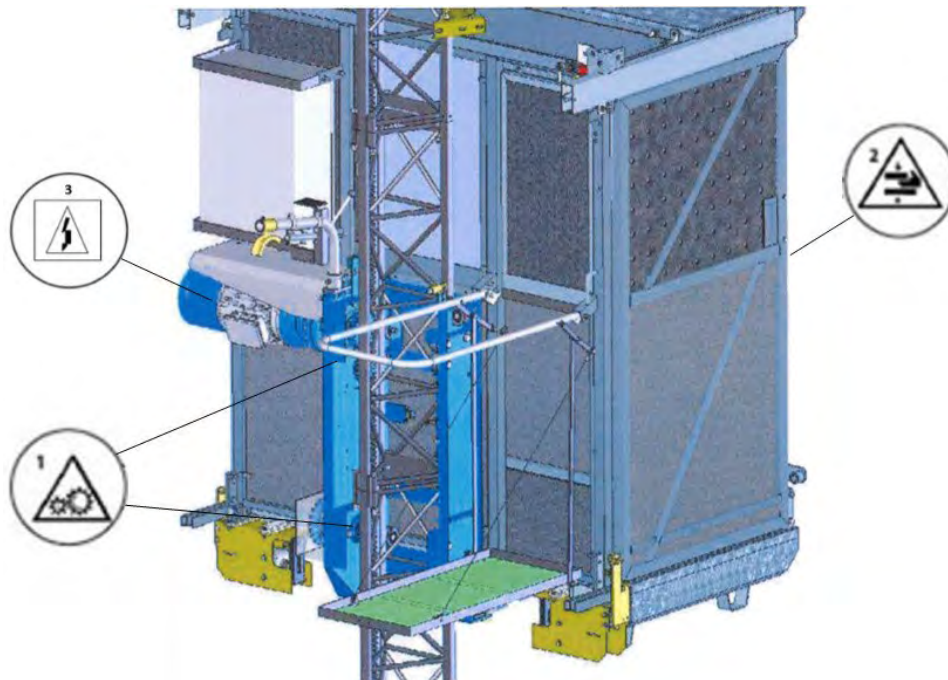

Figure 8.6

Other signs are placed inside the loading unit to identify the type of machine, the load and safety indications to be adhered to during operation and installation.

The figure shows the layout of such signs:

1. **Identification plate.** The sign provides clear identification of the type of machine, the manufacturer, the serial number and the machine's main characteristics.
2. **Load plate.** The sign allows you to clearly see the possible load combinations, which the machine is designed for.
3. **Safety indications plate.** The sign describes the safety requirements that are necessary to operate the machine including those of the qualified operators.
4. **Safety indications plate.** This sign allows you to clearly see the safety requirements to be adhered to, to avoid dangerous situations during the installation of the vertical components.



Figure 8.7

8.6 FUNDAMENTAL SAFETY REGULATIONS

Over the years, serious accidents have occurred during the assembly and disassembly operations of machines having a rack and pinion. These accidents have a human factor in common, such as failing to comply with safety regulations and lack of good sense. This document is for all personnel, including general workers, involved in the assembly and disassembly operations and those assisting in such operations.

As an example, if a worker leans out of the opening that is to mount the masts, while the machine is in motion, he can be hit by a wall anchor; or, if the bolts used on the vertical mast are not completely installed and tightened, this may cause the mast sections to separate and the lifting unit to fall, resulting in serious injuries or possible fatalities. Many other cases or examples can be given. To avoid accidents from being caused, read these instructions attentively. Do not be hasty in carrying out your work and always ensure that it has been done properly.

8.6.1 General safety regulations

Always adhere to the instructions described below in order to carry out correct installation, use and maintenance operations:

- read all the warnings and instructions related to the work and/or danger
- keep the work area clean. Any oil spills must be immediately removed, in order to avoid the risk of slipping; in order to reduce the risk of stumbling over unnecessary material, remove them immediately (disassembled parts of the machine or any other)
- under no circumstances is the machine to be put in motion if a person is inside the base enclosure when the loading unit is raised onto the mast or at an anchor level. The power supply must be interrupted during these operations
- complete each operation before starting another or before taking a break. This is particularly important when the sections of the vertical mast are being tightened and when the anchors or other structural parts are being installed
- always apply the required torsion when tightening junction bolts (it is recommended to use a torque wrench), as shown in the relative specifications table
- if structural damage or significant corrosion is noticed in parts such as the mast sections or the anchors, machine operation must be immediately stopped and the damage must be identified and repaired before operating the machine again (these operations are to be carried out exclusively by authorized and particularly experienced personnel, otherwise, you must contact Beta Max Technical Support)

8.6.2 Local safety regulations

Strictly adhere to all national safety regulations in the country where the machine is installed.

8.6.3 Environmental conditions

The machines must not be assembled or disassembled if the wind speed exceeds 28 mph. In countries where local regulations are more restrictive, abide by the specific indications.

8.6.4 Pre-installation requirements

To install the machine correctly, the designated technical expert must:

- study the use and maintenance instruction manual attentively before starting the work
- secure the assembly/disassembly area from objects that may fall, by delimiting or closing off the area in such a way so as to prevent access to outsiders, who are not authorized or who are not equipped with suitable protection devices or gear
- forbid unauthorized personnel from accessing the machine, during assembly, disassembly and normal operation

8.6.5 Individual protection gear regulations

Protection and safety gear pertaining to the work being carried out must be used and/or worn, such as hard hats, safety shoes, safety harness, or any other, which is suitable to prevent injuries.

DANGER:

It is absolutely prohibited to work on the machine without utilizing the above-mentioned individual protection gear.

8.6.6 Regulations pertaining to electricity

Only competent personnel are to perform work on electrical parts. The power supply must be interrupted and shut off before commencing such work. All necessary measures must be taken in order to prevent the power supply from being turned back on, even inadvertently.

8.6.7 Regulations pertaining to spare parts

Only original or approved spare parts must be used.

8.7 REGULATIONS PERTAINING TO MAXIMUM LOADS

The admissible load on the machine must be in accordance with its configuration and the tables placed on the machine itself regarding maximum loads.

The site manager, who is responsible for the installation process, must verify the machine's layout and affix the plate indicating the loads, relative to this layout, as stipulated earlier on.

NOTE:

All data pertaining to the maximum installation height, loads and maximum number of persons allowed to be transported on the machine, strictly pertains to standard installations given in this manual and is not applicable to non-standard configurations.

ATTENTION:

You are recommended to contact BETA MAX technical support regarding non-standard installations, which are not included in this manual.

The plates indicating the maximum loads of the machine are illustrated below.

MC2000PMB may have a maximum of 7 people or 2000 lbs. as per **ANSI A10.4**.



Figure 8.8

8.8 RESIDUAL RISKS

This paragraph is intended to highlight the residual risks associated with the operations covered in this manual. The major risks can be identified in the particular situations mentioned below:

- risks arising from operating with configurations not provided for by the manufacturer
- risks arising from positioning the machine incorrectly
- risks arising from transporting the machine
- risks arising from incorrect assembly on the ground
- risks arising from incorrect overground assembly
- risks arising from functional verification of the machine
- risks arising from the machine's normal operation
- risks arising from descending the machine manually
- risks arising from handling the machine in the construction site
- risks arising from disassembling the machine

A detailed description is given for each of these situations, indicating the stage of operations, the equipment used, the possible risks and relative prevention and safety measures.

8.8.1 Risks arising from operating with configurations not provided for by the manufacturer

The measurements of the machine and its conformation in respect to the building in question must be confirmed in the construction site itself, before commencing the machine's assembly operations. The drafted and executive project plans of the building in question together with the Use and Maintenance Instruction Manual of the machine must be consulted for such verification.

Possible risks:

- differences between the measurements in the plans and the actual measurements of the building
- overground obstacles
- verification of the machine's anchor positions
- errors in the assembly configuration of the machine

Prevention and safety measures:

- verification of any overground obstacles in the construction site that prevent the regular assembly of the machine, with particular reference to power and telephone lines anchored to the building. In the case of obstacles being found, a different configuration must be planned for the machine
- the person responsible for the installation process must decide upon the positions of the wall anchors in accordance with the Instruction Manual. If the standard solutions given in the Instruction Manual cannot be implemented because of particularities in the construction site, a plan will have to be drawn up for every anchorage and signed for by a qualified professional
- the person responsible for the installation process must ensure that the configuration chosen, based on the above-mentioned considerations, is actually mounted with no variations or modifications

8.8.2 Risks arising from an incorrect positioning of the machine

The position where the machine will be mounted is actually defined and the machine is prepared for this operation.

For this operation, the drafted and executive project plans of the building in question must be consulted, with particular reference to the underground and underlying conformation of the area chosen, together with the Use and Maintenance Instruction Manual of the machine.

Possible risks:

- weak flooring is chosen for the installed base unit to rest on
- underground pipelines or cavities
- difficulties with the power supply

Prevention and safety measures:

- the total load that will weigh on the machine's base unit flooring must be determined beforehand, based upon the indications given in the Instruction Manual. The person responsible for the installation must communicate the total intended loads to the Qualified Technician, who is designated by the Firm or by the Owner. After having carried out the necessary verification calculations, the Technician will issue a written statement certifying approval of the flooring which is to withstand the intended loads
- it must be ascertained that there are no pipelines, sewage systems or any other underground cavities that can result in the base unit giving way and/or sinking, at no point in time during the operational life of the machine
- a suitable power supply, which is in accordance with the regulations, is to be organized together with the earthing system

8.8.3 Shearing risk deriving from the machine proximity to obstacles

When the machine moves within a safe distance from any obstacles, the risk is present of shearing for people on board machine or present on structures adjacent to machine elevation path. By obstacle it is meant any object which is protruding towards the machine elevation path to a safe distance from it (trees, streetlamps, suspended cables, terraces floor slabs, steel beams, etc.).

Possible risks:

- shearing risk / trapping hazard for people moving on buildings or structures adjacent to machine elevation path
- shearing risk for people on board the machine

Prevention and safety measures:

- wherever possible, install a barrier of at least 8 ft. high protecting the machine against any obstacle near its elevation path

8.8.4 Risks arising from transporting the machine

The machine and its accessories are actually unloaded. The material is set according to the position chosen for the assembly operation.

For this operation, all the documents pertaining to the configuration together with the Use and Maintenance Instruction Manual of the machine must be consulted. Moreover, all the necessary means must be employed for lifting and transporting the material in question.

Possible risks:

- breakages or damages to the material
- instability of the material when deposited in piles
- errors in the material or configuration to be installed
- personnel knocking, pinching, or shearing limbs
- personnel suffering from trauma due to exertion

Prevention and safety measures:

- the person responsible for the installation must see to inspect the components to verify their structural integrity
- the stability of the material piled up must be ascertained to prevent it from giving way or slipping
- the person responsible for the installation must verify that the required components for the configuration to be installed are prepared accordingly, paying particular attention to components that could create confusion due to their similarity with others
- all loads that are to be mechanically moved must be adequately strapped with adjustable cables, belts or chains. Only one operator must be responsible for signaling the required maneuvers to the operator driving the unloading/loading vehicle and he must use regulatory signs. Personnel not involved in this operation will remain at a safe distance. Nobody must pass under or stop beneath suspended loads, and the area in question must be closed off and marked
- the personnel designated to manually move the material must be informed of the weight of each component and the best way to handle it

8.8.5 Risks arising from incorrect assembly on the ground

The first components of the vertical mast, wall anchors and the frames of the electric cable guide are assembled.

For this operation, all the documents pertaining to the configuration together with the Use and Maintenance Instruction Manual of the machine must be consulted. Moreover, all the necessary means must be employed for lifting and transporting the material in question.

Possible risks:

- errors in the assembly process
- assembly is not compliant with the authorization given
- falling material or equipment
- errors in the electrical connections

Prevention and safety measures:

- all personnel designated for the assembly process must be qualified and must be perfectly aware of the procedures given in the Instruction Manual of the machine. Particular attention is to be given when positioning and fastening each component precisely while carefully following the indications of the Instruction Manual
- during the installation process, exact correspondence must be verified between the work carried out, the assembly layout given with the authorization and that of the Instruction Manual
- personnel involved in the installation operations must constantly wear the safety hard hat, safety shoes and work gloves. Nobody is to be allowed to stop beneath or pass under the machine during the assembly process
- all electrical connections must be carried out exclusively by qualified personnel and their functionality is to be verified before being used

8.8.6 Risks arising from incorrect overground assembly

The machine's vertical masts are assembled, and the relative wall anchors are implemented with the relative protruding sections, which are necessary for fastening the masts.

For this operation, all the documents pertaining to the configuration together with the Use and Maintenance Instruction Manual of the machine must be consulted. Moreover, all the necessary means must be employed for mounting the masts and anchors.

Possible risks:

- errors in the assembly process
- assembly is not compliant with the authorization given
- falling material or equipment
- defects in implementing the wall anchors
- personnel shearing limbs
- obstructions in the machine's path
- incorrect positioning of the end-of-travel

Prevention and safety measures:

- all personnel designated to the assembly process must be qualified and must be perfectly aware of the procedures given in the Instruction Manual of the machine. Particular attention is to be when positioning and fastening each component precisely while carefully following the indications of the Instruction Manual
- during the installation process, exact correspondence must be verified between the work carried out, the assembly layout given with the authorization and that of the Instruction Manual
- personnel involved in the installation operations must constantly wear the safety hard hat, safety shoes and work gloves. Nobody is to be allowed to stop beneath or pass under the machine during the assembly process
- all the anchors must be implemented in accordance with the instructions given by the person responsible for the installation process. If an anchor seems to be inadequate, the works in progress must be put on hold and the situation is to be reported to the person responsible for the installation process
- only one operator is to handle the movement of the machine. The operator will carry out each maneuver only after having ascertained the position of all the other operators, who must remain in their safe positions. Before putting the machine in motion, all objects placed on the machine must be secured in order to prevent them interfering with the maneuvers or possibly falling
- when the machine is in motion, utmost care must be taken in order to avoid a member of staff from being crushed under the protruding parts
- when the machine is in motion, utmost care must be taken to ensure that the machine's path is not somehow obstructed
- the safety end-of-travel devices must be positioned in such a way so as to let the machine work between two adequate heights, whilst preventing an impact with the base unit and also preventing the upward movement going beyond the upper limit of the mast (top mast)

8.8.7 Risks arising from functional verification of the machine

Correct functionality of all of the machine's driving and safety devices is verified together with the correct movement of the machine itself.

For this operation, all the documents pertaining to the configuration together with the Use and Maintenance Instruction Manual of the machine must be consulted.

Possible risks:

- errors in the assembly process or in the electrical connection
- falling material or equipment
- incorrect adjustment for the downward motion of the machine

Prevention and safety measures:

- all personnel designated to the assembly process must be qualified and must be perfectly aware of the procedures given in the Instruction Manual of the machine. All the functions of the normal drive must be verified, starting from the simpler operations and proceeding onto the more complex ones
- if, for any reason whatsoever, difficulties arise in completing the functional test when driving the cabin downwards and it is considered to be further complicated to drive the cabin down to the ground, the designated personnel will immediately suspend the test. The personnel must ensure their safety by fastening the safety-belt's spring-clip to the fall protection rope, which will be connected to an appropriate structural part of the building. The safety manager must be informed and under his supervision, the personnel are to be evacuated from the cabin with the help of qualified personnel

8.8.8 Risks arising from the machine's normal operation

The machine is used for normal operation in the construction site.

For this operation, the Use and Maintenance Instruction Manual of the machine must be consulted.

Possible risks:

- the machine is overloaded
- personnel, material or equipment fall when work is being carried out
- the machine stops working due to a power failure
- a wall anchor loosens
- the machine stops working due to a failure in the lifting unit

Prevention and safety measures:

- all personnel designated to the machine's functionality must be qualified and must be perfectly aware of the procedures given in the Instruction Manual of the machine. The site manager must supervise the loading operations, ensuring not to overload the machine
- the personnel must take care to remain inside the cabin and must never use ladders, provisional bridges or any other device to reach a higher level or protruding part
- if a power failure occurs, the safety manager must be immediately informed and he will see to organizing the necessary interventions to restore the working conditions. The personnel onboard must remain safe and must not implement any improvised maneuver. If it is not possible to resolve the problem promptly, the personnel must follow the procedures given in the Instruction Manual to descend the machine manually
- the wall anchors must be checked periodically, especially after particularly intense weather conditions, under the supervision of the safety manager. If an anchor is found to be loose, all personnel must be evacuated from the cabin and a new wall anchor must be implemented;
- if a failure is verified in the lifting unit, the safety manager must be informed and under his supervision, all personnel must be evacuated from the cabin, and the defect is to be repaired by the maintenance personnel or by BETA MAX Technical Support

8.8.9 Risks arising from descending the machine manually

The machine is driven to the ground floor level or to the closest landing platform following a failure in the lifting unit.

For this operation, the Use and Maintenance Instruction Manual of the machine must be consulted.

Possible risks:

- intervention of the safety brake device
- the motor brakes overheat
- unusual wear and tear of the motor brakes
- impact between the loading unit and the base unit if the machine is driven to ground level

Prevention and safety measures:

- implement the manual descent maneuver by meticulously following the indications given in paragraph “MANUAL DESCENT PROCEDURE” in this manual
- it is prohibited to provoke the intervention of the safety brake device for the cabin to gain speed. In fact, should this occur, it will not be possible to operate the machine unless qualified personnel from BETA MAX Technical Support intervenes
- you are to absolutely avoid driving the cabin downwards for long distances as the motor brakes can overheat and/or wear out. In fact, should this occur, the machine could start going down uncontrollably, resulting in the safety brake device intervening, after which it will not be possible to operate the machine unless qualified personnel from BETA MAX Technical Support intervenes
- if the cabin is driven right down to the ground floor, the operator must pay utmost attention in not bringing it down too fast as this impact with the base unit’s shock absorbers could cause damage to the machine itself or injure the operator

8.8.10 Risks arising from handling the machine at the construction site

With the use of lifting equipment, the machine is moved from one area to another, within the same construction site where it has been installed.

For this operation, the Use and Maintenance Instruction Manual of the machine must be consulted. Moreover, all necessary measures must be taken to eliminate the risks arising from the lifting process of the machine.

Possible risks:

- inadequacy of the lifting equipment
- inadequate positioning

Prevention and safety measures:

- always ensure that the lifting equipment used is able to lift the machine within a large margin of safety
- to handle the machine, always position the lifting blades or the anchor cables as described in this instruction manual, in order not to damage the machine's structure
- always check the adequacy of the supporting surface onto which the machine is to be repositioned and carry out the re-assembly operations of all the service and anchor structure on the building in question, in accordance with all that stipulated in this instruction manual

8.8.11 Risks arising from disassembling the machine

The machine's vertical masts are disassembled together with the relative wall anchors.

For this operation, the Use and Maintenance Instruction Manual of the machine must be consulted. Moreover, all necessary measures must be taken for the disassembly of the masts and anchors.

Possible risks:

- instability of the disassembled components
- instability of the machine
- personnel, material or equipment fall when work is being carried out

Prevention and safety measures:

- pay particular attention when positioning the disassembled components, always following the indications given in the Instruction Manual, precisely
- disassemble the anchors at the same pace as the mast's vertical components so as not to cause instability to the machine
- personnel must take care to remain inside the parapets on the upper part of the loading unit and within the perimeter of the mounting platform; they must also never use ladders or provisional bridges to reach the wall anchors. Everyone must be prohibited from passing under or stopping below the cabin and the area must be properly enclosed

This page has been left blank for formatting purposes

CHAPTER 9: PREPARATION FOR MACHINE USE

Record of modifications

Revision	Executor	Date	Description of modification

9 PREPARATION FOR MACHINE USE

9.1 SAFETY REQUIREMENTS BEFORE HANDLING THE MACHINE

Once the machine is mounted and the electrical connection is set, it is good practice to carry out a number of verifications to ascertain its functionality.

Before handling the machine verify that:

- the base enclosure has been mounted correctly, preventing anyone from stepping into or stopping inside the area where the loading unit descends
- adequate signs, which are easily visible and/or bright, have been set in place
- there are no power lines in the machine's path or in its immediate vicinity, which can constitute a risk for the operator's safety
- there are no materials nor protruding components in the machine's path, which can hit the workers or hinder the machine's regular movement
- all the machines' mechanical, electromechanical and electrical safety devices work perfectly well
- the rack, pinions, and sliding wheels are in perfect working condition
- the belts used in any emergency are readily available on the machine (where required from the operation plans of the site)
- when the cabin is driven upward or downward, the personnel onboard are positioned in such a way so as to spread the load in a uniform manner
- the emergency brake control, which triggers the interruption of the entire control circuit, immediately stopping the machine's movements, works perfectly well
- the wind speed is less than 40 mph otherwise the cabin must be brought down
- in case of a power failure, the cabin can be brought down to the ground level by acting upon the lever of the manual release of the motor brakes, very cautiously. The operation must be carried out by BETA MAX Technical Support personnel or by specialized personnel, specially trained in maintenance and repairs
- there is no snow or ice on the machine, otherwise it is obligatory to see that this is removed
- the drive direction of the machine is in accordance with the pressed drive button
- after having carried out the trial run, all the upward/downward stopping devices function correctly

After having carried out the verifications described above, the machine is ready for its normal operation on a construction site.

9.2 SAFETY REQUIREMENTS DURING MACHINE OPERATION

In order to work safely, always remember the following requirements during machine operation:

- it is strictly forbidden to construct work levels which are higher than the loading unit
- when the loading unit is elevated, the machine can only be abandoned in the case of an emergency and making use of the appropriate fall protection devices
- the cabin is to be brought down to ground level, as soon as possible, in every instance and any kind of failure

DANGER:

When failure occurs during machine operation, take the necessary steps to resolve this before utilizing the machine again.

- at the end of each working day, the cabin must be brought down to its lowest position and the power supply must be disconnected, storing the power cable separately, in a safe place.

9.3 SAFETY VERIFICATION INSTRUCTIONS

The Technicians, who are responsible for the machine's start up and maintenance, are to refer to the instructions given below in order to verify the functionality of the installed safety devices and to ensure that all parts of the machine work perfectly well. These instructions are also found in abbreviated form on the labels onboard the machine.

9.3.1 General verification of the machine

In order to ensure that the machine's mechanical components are working perfectly well, proceed as described below:

- in case of a storm, tornado, hurricane or earthquake, all essential parts of the machine must be checked by a professional or an authorized inspector, before putting the machine back into operation
- if the machine is installed outdoors, it must not be used if the wind speed exceeds 40 mph
- if the machine is exposed to frost, the cabin must be brought down to the landing floor level, once the work is carried out. If the mast and/or the power cable are covered in ice, remove this before operating the machine ensure that no equipment or material is suspended from the machine's structure

DANGER:

It is strictly forbidden to suspend any equipment or material from the machine's lifting structure.

ATTENTION:

A safety inspection must be carried out every day before operating the machine.

9.3.2 Electrical verification of the machine

In order to test and ascertain that the electrical command and control devices work perfectly well, proceed as described below:

- check that all the emergency buttons and main switches of electric panels function properly. For this purpose, carry out trial runs with each EMERGENCY buttons pushed, and each switch set to the “0” position. In all instances the machine must not move
- verify synchronization by carrying out trial runs with the base enclosure doors, platform doors, and the floor level doors open. In all instances the machine must not move

NOTE:

Carry out the verification tests with one switch at a time in order to clearly identify any malfunctions.

- perform trial runs in order to verify the functionality of the end-of-travel devices
- also check that the pads and the end-of-travel devices are fastened well

9.3.3 Verification of the machine's motion

In order to test the cabin's motion, proceed as described below:

- visually check the machine's cable guide and ensure that it is free from any obstacle. Monitor this constantly
- while the loading unit is on the ground level, turn the main switches of base and onboard control panel to the “1” position
- ensure that the load does not exceed the maximum allowed - refer to the information given on the label indicating the load capacity
- close the floor level doors, the base enclosure door and the access doors to loading unit properly
- press the push button to drive the loading unit in the desired direction and the machine will start-up. At the extreme floor levels, the cabin will automatically stop by means of the end-of-travel cams placed on the mast. During the race, press the STOP NEXT LANDING push button when the machine approaches the floor chosen for the landing to see if it shuts down automatically

9.3.4 Daily verification prior to operating the machine

Every day, before starting to operate the machine, proceed as described below:

- ensure that no equipment or material is suspended from the machine's structure that can interfere with the machine's path
- ensure that the mast and the power cable are not covered in ice; if so, remove this before operating the machine
- in case of particularly intense weather conditions, all the essential parts of the machine must be checked
- if the wind exceeds the threshold indicated, prohibit all persons concerned from using the machine
- check the power cable; this must not be damaged in any way
- check the supports of the cable guide and its rubber supports
- ensure that the loading unit is not damaged in any way
- check the base enclosure, its access doors and the floor level access doors
- verify the functionality of the emergency devices
- verify the functionality of the end-of-travel and over-travel devices
- verify the functionality of the electrical interlocking systems on the access doors of the loading unit, the base enclosure and those to the floor level landings
- verify the functionality of the mechanical interlocking systems on the base enclosure and those of the floor level landings
- verify the functionality of the upward and downward end-of-travel devices

After having carried out the verifications described, the machine is ready for its normal operation in a construction site.

DANGER:

An approximate assessment of the operation conditions is the greatest and most common cause of accidents, often with a fatal outcome.

9.4 MANUAL DESCENT PROCEDURE

When the machine is in use, if a failure occurs in the lifting unit while it is over ground, the manual descent procedure must be implemented until the personnel onboard can get out onto a floor level or the machine reaches a safe height.

ATTENTION:

Never leave the descent lever for manual release in the motor.

To implement this operation, proceed as described below:

- the main switch of the onboard control panel has to be set to the “0” position
- locate the brake/door lock release handle mounted on the cabin enclosure through the access panel (A)
- rotate the access panel and locate the release lever (B) inside the opening

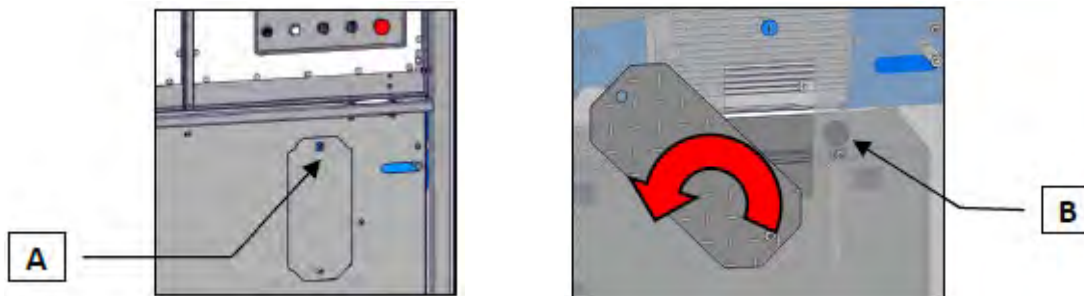

Figure 9.1

- insert through the cabin enclosure at the brake release slot and into the brake release handle adapter

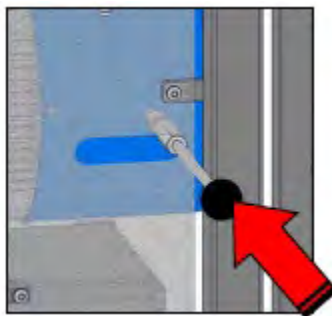

Figure 9.2

- act upon the relevant lever installed on the motor
- act upon the lever with extreme caution and very lightly for a short while, for the cabin to start descending without gaining speed

ATTENTION:

Descending at too rapid a rate will cause the activation of the overspeed brake.
If the overspeed brake engages no further descent is possible.

DANGER:

Only lower the machine with all doors closed and locked, the mast guard installed, and the roof hatch closed and locked.

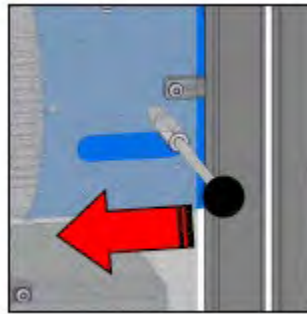

Figure 9.3

- stop after a short distance is covered so that the brake can cool down properly; this prevents the brake lining from overheating and burning out, resulting in speed control being lost and the lifting unit dropping downwards. As an example, the operator can cover a distance of about 10 ft, equal to two masts, and must then let the brake cool down for about 1 minute

ATTENTION:

If the machine gains too much speed during the manual descent procedure, resulting in the lifting unit free-falling, the safety brake device will intervene. In this case, the machine cannot be handled without the intervention of qualified personnel from BETA MAX's technical support.

- as soon as the lifting unit reaches a floor level where the personnel onboard can get off, the machine must be stopped and abandoned. The door locks can be manually opened by inserting the door lock/brake release handle in the available access hole in the floor of the platform and manually pushing the lock open.

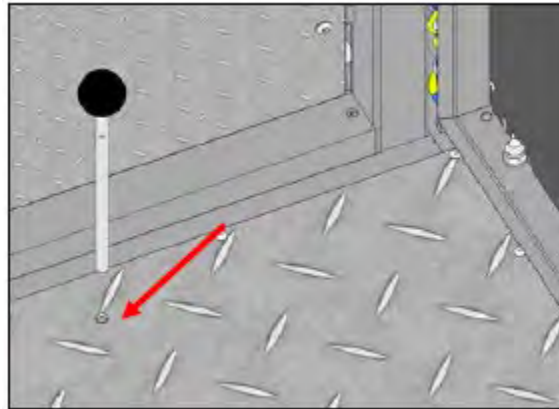

Figure 9.4

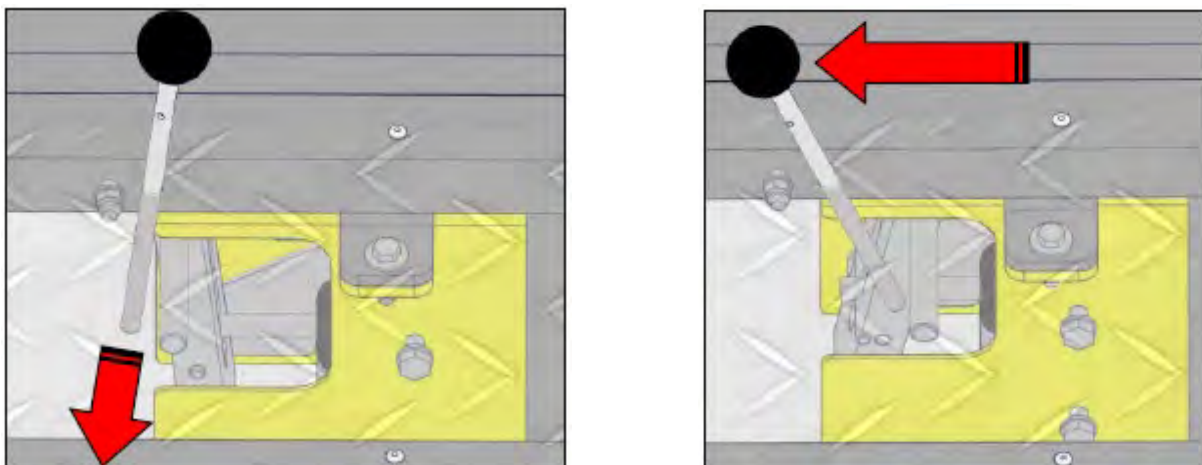

Figure 9.5

- Bringing the cabin back to ground floor level or carrying out the necessary repairs over ground is a task which is to be carried out by the personnel from BETA MAX Technical Support or qualified personnel appropriately trained in maintenance and repairs

9.4.1 General regulations to descend manually but safely

Members of staff, who are given the responsibility of descending the machine manually, must be appropriately and particularly prepared and all operators concerned with this procedure must always keep the following safety warnings in mind.

ATTENTION:

If it is not possible to carry out the manual descent procedure, remain on the machine and call the safety manager, for all persons and material to be evacuated with suitable means.

DANGER:

Releasing the brake for the machine to descend, is a task which is to be carried out by personnel from BETA MAX technical support or qualified personnel who are appropriately trained in maintenance and repairs. The persons designated to work on the machine, which happens to be over ground when the failure occurs must limit their selves to driving the cabin down, by means of the brake release, solely till a floor level is reached where they can get off or until the machine reaches a safe condition.

DANGER:

Implement the brake release maneuver for very short distances, at a maximum speed equal to 1/3 of the normal working speed. Moreover, when this maneuver is carried out, it is necessary to stop for at least 1 minute every 20 seconds of descent so that the brakes can cool down. It is very important to implement this procedure because if the brakes overheat, this could put the entire braking system at risk with very serious consequences.

9.5 OPERATING THE MACHINE

Operators who are appropriately trained can operate the machine.

Once all the verifications and programming have been carried out on the machine by qualified Technicians who are responsible for the construction site and the machine mode key switch has been turned to the “NORMAL” position for normal use, proceed as described below:

The display screen will display:



Figure 9.6

Destination = Destination floor (value from 1 to the last recorded floor, Max = 50)
 Actual = Current floor

- adjust the FLOOR TO REACH destination floor by pressing the INCREASE FLOOR push button to increase the floor value by one unit or by pressing the DECREASE FLOOR pushbutton to decrease the floor value by one unit, keeping either button pressed will increase or decrease the value quickly
- press and hold the RUN/OPERATOR pushbutton until the machine is positioned at the desired floor level or FLOOR TO REACH destination floor
- if a floor level is desired while in motion to the FLOOR TO REACH destination floor, press the STOP NEXT FLOOR push button and the machine will stop at the next floor level towards which the machine is moving
- if running from any elevated position to the ground level, decreasing the FLOOR TO REACH destination floor to 0 (ground floor location) is not required, press and hold the SEND TO GROUND push button. The machine will travel directly to the ground floor location no matter what desired floor (FLOOR TO REACH) is set on the display

ATTENTION:

Before utilizing the machine in any way, all safety procedures must be implemented, and maintenance and lubrication procedures must be carried out as stipulated in the relative chapter of this manual.

DANGER:

It is strictly forbidden to enter the base enclosure or stop beneath the machine's path when this is in operation.

9.6 OPENING OF GATES FOR EGRESS TO BUILDING

Whenever egressing the hoist platform to a building floor equipped with a suitable access gate, it is necessary to open in accordance with the following procedure:

- open the door on board the machine using the handle (A)
- ensure that the platform is level with the landing floor to create a safe passage between machine and access gate on the building
- open the gate placed on the floor of the served building from the hoist way side into the building

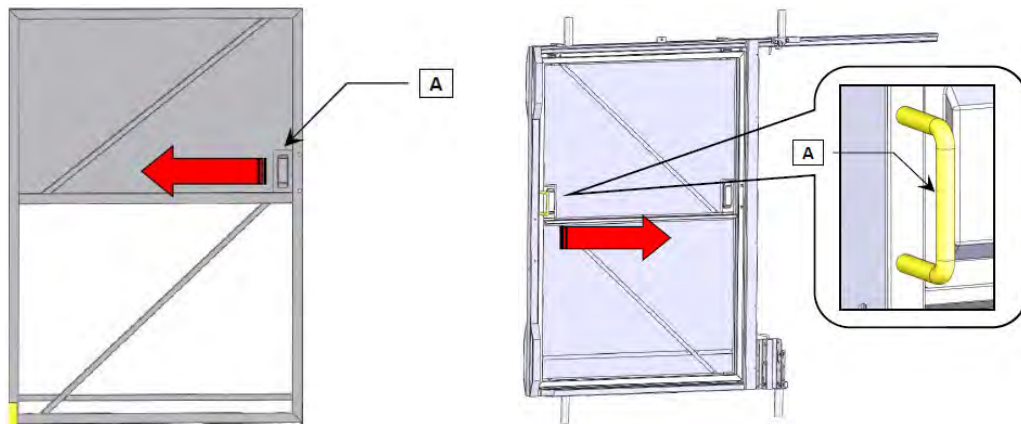

Figure 9.7

DANGER:

It is strictly forbidden to open the gate on the building side without first opening the door on the machine side.

9.7 SHUTTING DOWN THE MACHINE AT THE END OF A WORK SHIFT

Once a work shift is over, proceed as described below to shut down the machine:

- drive the cabin to the ground floor level until it stops at the lower end-of-travel device. Put the main switch of the base and onboard control panel in position “0”. Disconnect the machine from the power supply. Ensure that nobody has access to the machinery when there is no personnel present who is responsible for the machinery

9.8 SHUTTING DOWN THE MACHINE FOR LONG PERIODS

To shut down the machine for long periods of time, proceed as described below:

- carry out the procedures explained for the end of a work shift. In case of ice, snow or heavy rain, before putting the machine back into operation, ensure that the integrity of the delicate parts has not been altered. Leaving the machine idle for a long period of time can cause some trouble such as, the motor brakes can lock, metal parts and gaskets can corrode

CHAPTER 10: TROUBLESHOOTING

Record of modifications

Revision	Executor	Date	Description of modification

10 TROUBLESHOOTING

10.1 THE MACHINE DOES NOT START

If the machine does not start up, the operator responsible for its maintenance must:

- ensure that the main switches of the base and onboard control panels is in the “ON” position and the machine is correctly supplied
- ensure that none of the EMERGENCY pushbuttons are pressed
- ensure that the platforms for mounting the anchors, all the access doors and the floor level doors are closed properly
- ensure that no switch has interrupted the power supply
- ensure that no alarm light is lighted on electrical panels
- ensure that the safety brake device is not intervened

10.1.1 ALARM/ERROR messages on display

The DISPLAY screen indicates to the operator alarms or errors of the unit.

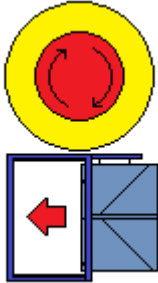
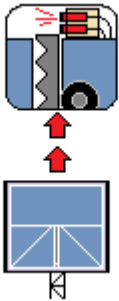
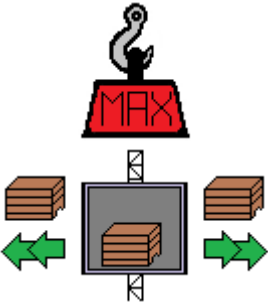
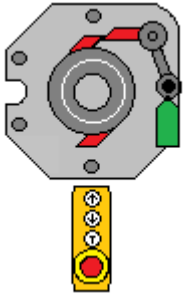

Figure 10.1

- S1 Alarm Banner:** this message shows hoist alarm (with code and description).
- S2 Image on Alarm:** image of the alarm corresponding to the code.
- S3 Code of Alarm:** code of the alarm visualized on the screen.
- S4 Specific Message:** some alarm codes, such as inverter or overload control, have a code or specific message with more detail.

Some alarms automatically disappear from the screen once the error is corrected. Others need to be reset by pressing the **Alarm Reset** button.



CODE	IMAGE	DESCRIPTION
01		<p>AL01: EXTERNAL EMERGENCIES</p> <p><i>Verify, if necessary, release floors emergency pushbuttons.</i></p> <p><i>Verify, if necessary, release emergency button on the base enclosure electrical panel.</i></p> <p><i>Check if all the landing doors are correctly closed.</i></p> <p><i>Check if the doors of the base enclosure are correctly closed.</i></p> <p><i>Check that the maintenance moveable prop is in correct position and dedicated emergency pushbutton unlocked.</i></p> <p><i>Check the landing doors extensions cable and all the connectors.</i></p>
02		<p>AL02: RACK END</p> <p><i>Lack of mast</i></p> <p><i>Mast without rack</i></p> <p><i>After checking on causes, manually lower the cage for 5 cm acting on brake levers (refer to dedicated instructions before proceeding).</i></p>
03		<p>AL03: MAXIMUM LOAD ADMITTED</p> <p><i>Decrease the number of people transported inside the cage and then reset the alarm. If a message appears under the picture, there is an error in the overload device. The alarm code number is the same that appear in the display of the overload detection device (installed inside the cage electrical panel). Write down this code and try to reset the alarm. Refer to the device maintenance manual. If the problem persists, contact BETA MAX technical service or the authorized dealer.</i></p>
04		<p>AL04: SAFETY EMERGENCY BRAKE</p> <p><i>Inspect the reason of safety brake intervention and re-set the normal working conditions of the machine.</i></p> <p><i>Lift the machine from outside the cage with the use of drop test pendant.</i></p> <p><i>If the problem persists, contact BETA MAX technical service or the authorized dealer.</i></p>

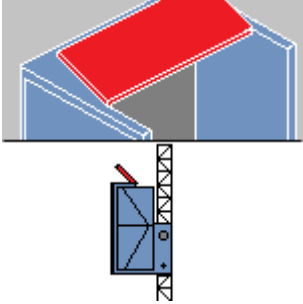
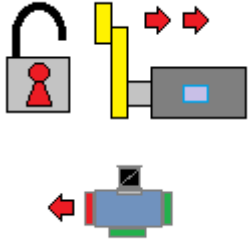
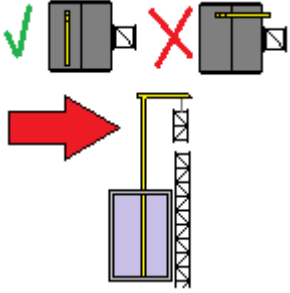
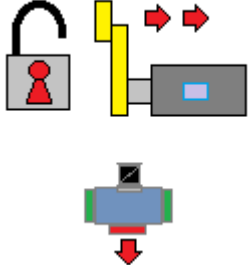

<p>05</p>		<p>AL05: ROOF OPEN</p> <p><i>Check if the door is completely closed and locked.</i></p> <p><i>Check the correct functioning of the door-locking device.</i></p>
<p>06</p>		<p>AL06: LEFT DOOR NOT LOCKED</p> <p>This alarm appears on the screen in 3 second when you keep pressed the “Send to landing” button and the machine is not running.</p> <p>Check if the door is completely closed.</p> <p>Check the correct functioning of the door-locking device.</p>
<p>07</p>		<p>AL07: ERECTION CRANE</p> <p>Check the correct orienteering of the crane.</p> <p>Check the correct functioning of its limit switch.</p>
<p>08</p>		<p>AL08: CENTRAL DOOR NOT LOCKED</p> <p>This alarm appears on the screen in 3 second when you keep pressed the “Send to landing” button and the machine is not running.</p> <p>Check if the door is completely closed.</p> <p>Check the correct functioning of the door-locking device.</p>



<p>09</p>		<p>AL09: UP ULTIMATE LIMIT SWITCH</p> <p>If the machine is overrunning, then:</p> <ul style="list-style-type: none"> - Check if the upper stop cam is present and strongly fixed in the mast. - Check the lever of the upward slow-speed limit switch - Check the lever of the upward stop limit switch <p>Inspect correct working of each of those limit switches</p>
<p>10</p>		<p>AL10: DOWN BOTTOM ULTIMATE LIMIT SWITCH</p> <p>If the machine is overrunning, then:</p> <ul style="list-style-type: none"> - Check if lower stop cam is strongly fixed on mast. - Check lever of the downward slow-speed limit switch - Check the lever of the downward stop limit switch - Inspect the correct functioning of each those limit switches - Lift the machine from outside the cage with the use of drop test pendant.
<p>11</p>		<p>AL11: RIGHT DOOR NOT LOCKED</p> <p><i>This alarm appears on the screen in 3 second when you keep pressed the “Send to landing” button and the machine is not running.</i></p> <p><i>Check if the door is completely closed.</i></p> <p><i>Check the correct functioning of the door-locking device.</i></p>
<p>12</p>		<p>AL12: EMERGENCY STOP PUSHBUTTON INSIDE THE CAGE</p> <p><i>Check and if necessary, unlock the emergency button on the electrical panel inside the cage.</i></p>

<p>13</p>		<p>AL13: EMERGENCY STOP PUSHBUTTON OVER THE ROOF</p> <p><i>Check and if necessary, unlock the emergency button on the electrical panel over the roof.</i></p>
<p>14</p>		<p>AL14: GENERIC EMERGENCY</p> <p><i>Check and if necessary, unlock the emergency button on the drop test pendant. Check and if necessary, insert the cap into the socket of the drop test pendant. Check all the connectors of the machine. Check the emergency main contactors if they work properly. Check the safety circuits.</i></p> <p><i>WARNING this operation must be performed only by skilled staff always complying with the Normative.</i></p>
<p>15</p>		<p>AL15: VFD ERROR</p> <p><i>The XXXX message is the alarm code number.</i></p> <p><i>Refer to the message shown in the alarm screen under this image. The alarm code number is the same that appear in the display of the VFD (installed on the roof electrical panel). Write down this code and try to reset the alarm. Refer to the device maintenance manual.</i></p> <p><i>If the problem persists, contact BETA MAX technical service or the authorized dealer.</i></p>

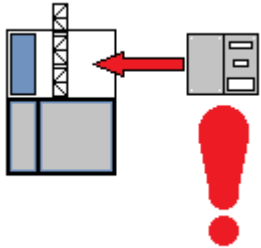
CODE	IMAGE	DESCRIPTION
16		<p>AL16: MAGNETHOTERMIC SWITCH INTERV. (BRAKE FAULT)</p> <p>Check the brakes of the two motors and, if necessary, re-arm the magneto-thermic switches of the two motors.</p> <p><i>WARNING: this operation must be performed only by skilled staff and complying with the normative.</i></p>
17		<p>AL17: INVERTED PHASES OR FEEDING LINE PHASE LOSS</p> <p>Power supply of the machine is not correct, check:</p> <ul style="list-style-type: none"> - the power supply cable - if there is a mistake in the cable - if the 3 phases are in the correct order <p><i>if there is a fault in the power supply</i></p>
18		<p>AL18: ENCODER ERROR</p> <p>There is a fault in the encoder:</p> <ul style="list-style-type: none"> - Check if it is strongly fixed in his shaft - Check if it is connected - Check if its cable is not damaged <p><i>If the problem persists, contact BETA MAX technical service or the authorized dealer.</i></p> <p><i>WARNING: in case of replacement of the encoder, all the floors level must be re-set and the procedure of floors record repeated (refer to the user & maintenance book)</i></p>
19		<p>AL19: OVERSPEED DETECTION</p> <p>The system detects an over speed of the hoist. Probably there is a fault in the VFD, or the machine has going upward or downward too fast than the maximum speed admitted. The alarm is activated when the movement of the cage is manually performed also. Check the encoder functioning.</p> <p><i>The alarm trigger is set at 50 m/min.</i></p>

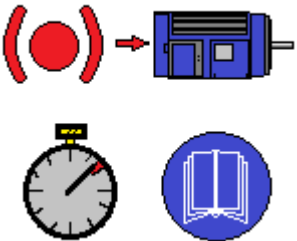
<p>20</p>		<p>AL20: UP SLOW-SPEED SWITCH ERROR</p> <p>The upward slow-speed limit switch not working properly:</p> <ul style="list-style-type: none"> - The lever does not return in the correct position - The contact inside the switch is not working properly <p><i>*This picture indicates the position of the switch considered in the line of the 4-motion control switch.</i></p>
<p>21</p>		<p>AL21: UP STOP SWITCH ERROR</p> <p>The upward stop limit switch does not work properly:</p> <ul style="list-style-type: none"> - The lever does not return in the correct position - The contact inside the switch is not working properly <p><i>*This picture indicates the position of the switch considered in the line of the - motion control switch.</i></p>
<p>22</p>		<p>AL22: DOWN SLOW-SPEED SWITCH ERROR</p> <p>The downward slow-speed limit switch does not work properly:</p> <ul style="list-style-type: none"> - The lever does not return in the correct position - The contact inside the switch is not working properly <p><i>*This picture indicates the position of the switch considered in the line of the 4-motion control switch.</i></p>
<p>23</p>		<p>AL23: DOWN STOP SWITCH ERROR</p> <p>The downward stop limit switch does not work properly:</p> <ul style="list-style-type: none"> - The lever does not return in the correct position - The contact inside the switch is not working properly <p><i>*This picture indicates the position of the switch considered in the line of the 4-motion control switch.</i></p>

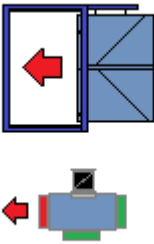
<p>24</p>		<p>AL24: SAFETY PROTECTION MAST GRID</p> <p>Check if the mast protection is correctly assembly and locked. Check the correct functioning of its limit switch.</p>
<p>25</p>		<p>AL25: CONTROLLER HARDWARE ERROR, (CHECK PLC)</p> <p>There is an error on the hardware (PLC).</p> <p>The message XXXX is the error code:</p> <ul style="list-style-type: none"> - 0001, input/output card not initialized. - 0002, input/output error on the card - 0003, input/output short circuit - 0004, input/output power supply error <p>If the problem persists, contact BETA MAX technical service or the authorized dealer.</p>
<p>26</p>		<p>AL26: MOTOR BRAKE OPENING TIMEOUT</p> <p>The brake do not open his brake or the brake is faulty. Check:</p> <ul style="list-style-type: none"> - The brake contactors - The rectifiers - The thickness of the brake disks - The gap of the brake coils <p>The functionality of the brakes micro-switch and their correct adjustment</p>

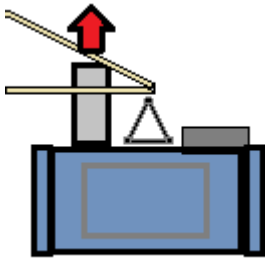
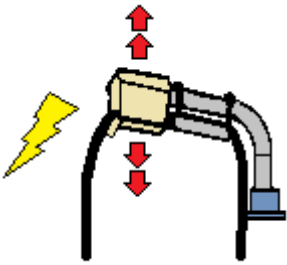
<p>27</p>		<p>AL31: LEFT DOOR OPEN Verify correct closure of left cage door.</p>
<p>28</p>		<p>AL28: PLC NOT CONNECTED WITH VFD There is a fault in communication from PLC to the VFD. Check if the ethernet cable that connect the control electrical panel to VFD electrical panel is correctly connected and not damaged. Try to switch OFF machine, after 5 seconds switch ON again. If the problem persists, contact BETA MAX technical service or the authorized dealer.</p>
<p>29</p>		<p>AL29: ERECTION PLATFORM Check correct closure. Check correct working of the limit switch. Check connectors caps, their correct fixing when the platform is not installed.</p>
<p>30</p>		<p>AL30: CABLE HOLDER Check the cable has not been caught somewhere. For important height, check springs setting. Check the device is clean and not damaged.</p>

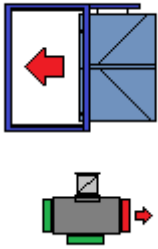
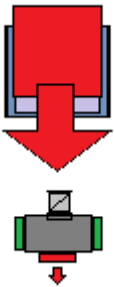
CODE	IMAGE	DESCRIPTION
31		<p>AL31: RIGHT DOOR OPEN</p> <p><i>Verify correct closure of right cage door.</i></p>
32		<p>AL32: CENTRAL DOOR OPEN</p> <p><i>Verify correct closure of the cage central door. (only for the machine supplied with this part)</i></p>

10.2 THE MACHINE STOPS ABRUPTLY

If the machine stops between two floor levels due to a power failure, a blown fuse or a switch having interrupted the power supply due to a power surge, etc., it can be manually lowered to the nearest floor landing.

To move the machine to the nearest landing floor, proceed as shown in paragraph, “MANUAL DESCENT PROCEDURE” of this manual.

If, for any reason, it is not possible to lower the cabin, remain inside the loading unit and call Beta Max Technical support.

ATTENTION:

If the machine's movement is blocked, call for technical assistance. Remain inside the machine until qualified personnel arrive. Solely for valid reasons is the machine to be abandoned, adopting the necessary safety measures.

CHAPTER 11: MAINTENANCE AND REPAIR

Record of modifications

Revision	Executor	Date	Description of modification

11 MAINTENANCE AND REPAIR

11.1 GENERAL INSTRUCTIONS

Regular maintenance of the mechanical and electrical components prolongs the machine's operational life, ensures best performance and is an important safety factor. Regularly verify the efficacy of the devices installed on the machine, in accordance with the indications given in this instruction manual.

Only specialized and authorized personnel are to carry out any maintenance or repairs on the electrical system.

The operator responsible for maintenance must remember the following:

- always use individual protection gear (gloves, earmuffs, safety shoes, goggles) when carrying out maintenance operations on the machine
- never start works on the machine before having interrupted all electrical power supply and ensuring that nobody can reconnect it, even inadvertently
- never to intervene on the machine by operating from under the work platform: all maintenance operations shall be carried out from the upper surface of the work platform or, with the machine resting on the ground, from outside the work platform perimeter
- only original spare parts are to be used whenever maintenance and repairs are carried out on the machine
- if the machine is shut down due to faults, maintenance or repairs, this must be made known by means of a warning sign
- once maintenance or repairs are carried out, ensure that no tools or items have been left inside the machine or in the loading unit
- the machine's devices are to be checked and tested in accordance with the stipulated regularity
- after having carried out maintenance operations, these must always be recorded in the appropriate register that is attached to this manual

ATTENTION:

If maintenance is not carried out in accordance with the above mentioned instructions, or not in conformity with that stipulated in this manual, it will be considered as improper use. BETA MAX disclaims all responsibility if the operator fails to comply with the requirements.

ATTENTION:

For repairs to be carried out, it is recommended to always contact authorized technical support or the Manufacturer of the machine. If maintenance and repairs are carried out incorrectly, without original spare parts or by personnel who is not specialized and authorized, the user of the machine bears full responsibility for its proper use.

11.2 MAINTENANCE SCHEDULE

Maintenance operations must be performed with the following timetable:

Maintenance every	Daily	it does not include the obligation to register the maintenance schedules
Maintenance every	40 hours	it does not include the obligation to register the maintenance schedules
Maintenance every	125 hours	it includes the obligation to register the maintenance schedules
Maintenance every	500 hours	it includes the obligation to register the maintenance schedules

Maintenance operations to perform according to the working hours of the machine are described in detail in the following paragraphs. The corresponding forms to be filled are attached to this manual.

ATTENTION:

To verify the periodic maintenance operations due, refer to the meter installed on the electrical control panel. This is the most reliable instrument to verify the machine's operational life, which in turn lets you check the operating time that has elapsed in between maintenance operations.

ATTENTION:

It is not obligatory for the maintenance operations, which are to be carried out daily and every 40 hours, to be recorded in the maintenance register. However, it is obligatory for the maintenance operations, which are to be carried out every 120 and 500 hours, to be recorded in the maintenance register.

ATTENTION:

If the machine remains installed for long periods of time, even if it is not used, maintenance has to be carried out every three months. This maintenance operation is to be carried out in the same way as the one due after 500 hours. If this is not carried out at the end of the three months, it is **OBLIGATORY** to carry out this maintenance operation when the machine is put back into operation. It is not obligatory for this intervention to be recorded in the maintenance register.

11.2.1 General maintenance (Daily)

Perform the maintenance described below:

- check for fallen hardware in pit area (ex. mast bolts, cable guides)
- check hoist way for obstructions
- check grease level in automatic greaser
- check for any signs of oil leaks around gearbox and motor
- check emergency stop pushbuttons and main switches
- perform trial runs with the emergency stop pushbuttons engaged to verify functionality
- perform trial runs with car door/ramp open to verify unit does not run
- check the functionality of the cabin light
- check the hoist controls are functioning and are undamaged
- perform a trial run to verify motor and motor brake is functioning
- check the trailing cable ensuring all of the cable is spooled into the cable drum
- check cable guides for missing or loose hardware
- check cable guides for missing rubber keepers
- check wall anchors for missing or loose hardware
- check mast sections for missing or loose hardware
- check functionality of the final travel stops

The General Maintenance (Daily) checklist form is located in appendix C of this manual.

11.2.2 General maintenance (40 hours)

Perform the maintenance described below:

- clean the cabin flooring and the area around the machine
- ensure that all warning signs are legible and in the right place
- ensure that all documents are readily available and legible
- check the oil level of the gearbox
- lubricate the swing arm shaft of the safety device through the proper grease nipple
- lubricate the indicated parts paying particular attention to the rack
- check the grease level of the automatic greaser
- ensure all connections of the guide rollers to the machine's frame are correct and tight
- check the rack of the mast and the motor pinion and ensure there is no damage, alignment errors, or defective connections
- ensure that the electric motor brake functions properly, the loading unit must stop within the set limits when the brake is applied
- visually inspect that all bolted joints between the components of the mast are present
- check mast ties for missing or loose hardware
- check cable guides for loose or missing hardware and rubber keepers
- check emergency stop pushbuttons and main switches
- check that the hoist controls are functioning and are undamaged
- perform trial runs with the emergency stop pushbuttons engaged to verify functionality
- verify the operation of the final travel stops
- ensure that all the mechanical and electrical synchronized systems function properly – both on the machine and on the floor levels
- check the trailing cable and ensure that this is not damaged, twisted, or pinched in any way
- check the trailing cable ensuring all of the cable is spooling correctly in the drum
- ensure that the safety device does not intervene unnecessarily and does not make noise
- check that the emergency alarm is functioning properly
- check that the cabin light is functioning properly

The General Maintenance (40 hour) checklist form is located in appendix D of this manual.

11.2.3 General maintenance (125 hours)

In addition to the controls concerning the maintenance of the 40 h, perform the additional maintenance described below:

- tighten all bolted joints between the components of the mast
- tighten all bolted joints of the wall anchors
- tighten the cable guides and check for missing rubber keepers
- check the functionality of the manual release mechanism of the brakes checking for damage
- clean any debris from the covers of the electric motor and fans
- check the functionality of the overweight sensor system

The General Maintenance (125 hour) checklist form is located in appendix E of this manual.

11.2.4 General maintenance (500 hours)

In addition to the controls concerning the maintenance of the 125 h, perform the additional maintenance described below:

- fully inspect the machine and structure and ensure there is no corrosion
- visually inspect the entire machine and ensure there is no deformations, mechanical damage to any of the components
- check all electrical cables, electrical connections, and gaskets
- perform drop test of safety device

Contact Beta Max technical support for inspection and any repairs.

The General Maintenance (500 hour) checklist form is located in appendix F of this manual.

11.3 FUNDAMENTAL MAINTENANCE OPERATIONS

The machine's main operations of inspection, verification and lubrication, recommended for all the maintenance operations mentioned above, can be carried out correctly by following the indications given below:

- verification of the lifting unit's pinions
- wear and tear verification of the guide rollers
- inspection of the mast rack
- verification and adjustment of the air gap of the motor brakes
- servicing the gear motors
- lubricating the machine
- calibration of the overweight sensor system

11.3.1 Verification of the lifting unit's pinion

To check the wear and tear of the pinion of the lifting unit, proceed as described below:

- drive the cabin to the shutdown position on the ground floor level and disconnect the electrical control panel from the power line
- from the rear end of the lifting unit, visually check and ensure that the teeth of the pinion are not damaged, and the length is not less than that specified below

Motor pinion (1) with a minimum length of 178 mm (7.008 in)

Motor pinion engagement to the rack must be between 1.5 mm (0.059 in) and 2 mm (0.079 in)

- if damages are found or the measurements do not fall within the limits indicated, replace the worn out component
- put the machine back on

Proceed as described below to measure the motor pinion gear length:

- place two 20mm diameter rods between two pinion teeth at 180°. The external measurement should be of about 180 mm (7.0866 in). If the measurement is 178 mm (7.008 in) or less the pinion needs to be replaced

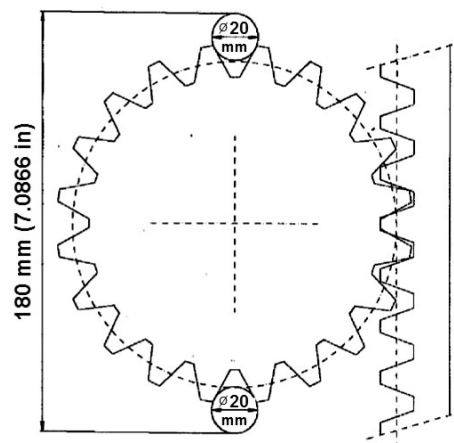

Figure 11.1

Proceed as described below to measure the motor pinion engagement to the rack:

- the play of “S” bottom-tooth must be between 1.5 mm (0.059 in) and 2 mm (0.079 in). If it is 3 mm (0.1181 in) or larger the pinion backup roller tension needs to be adjusted or the motor pinion replaced.

$$1.5\text{mm (0.059 in)} \geq S \geq 2\text{mm (0.079 in)}$$

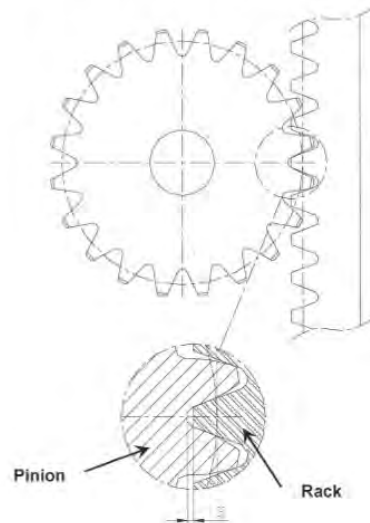

Figure 11.2

11.3.2 Inspection of the mast rack

Proceed as described below to measure the wear of the rack on all of the mast sections:

- Place a 16mm diameter rod between two teeth of the rack. Check by means of a gauge the distance from the upper part of the 16 mm rod and the opposite side of the square tube (T) of the mast. The external measurement must be approximately 80mm (3.15 in). If the measurement is 78.5mm (3.09 in) or less, contact Beta Max technical support.

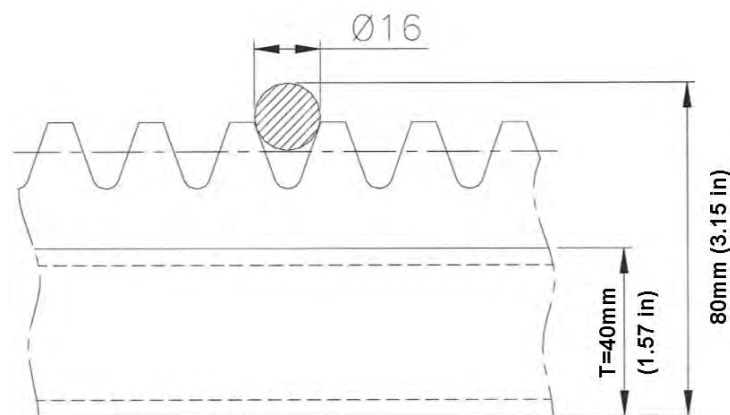

Figure 11.3

11.3.3 Inspection and maintenance of guide rollers

Proceed as described below to measure the wear of the guide roller:

- Verify the centering of the loading and lifting unit on the mast.
- Verify the vertical alignment of the lifting unit on the mast.
- Perform a visual inspection of the rollers. Looking for cracks, chips, or damaged bearings.
- In case of excessive vibration on decent, check the pinion back-up roller on the leaf spring. Verify solid contact between the back-up roller and mast. Replace this roller if the issue persists.

If guide roller diameters decrease more than 3mm from the measurements reported in Figure 11.5, replacement is needed.

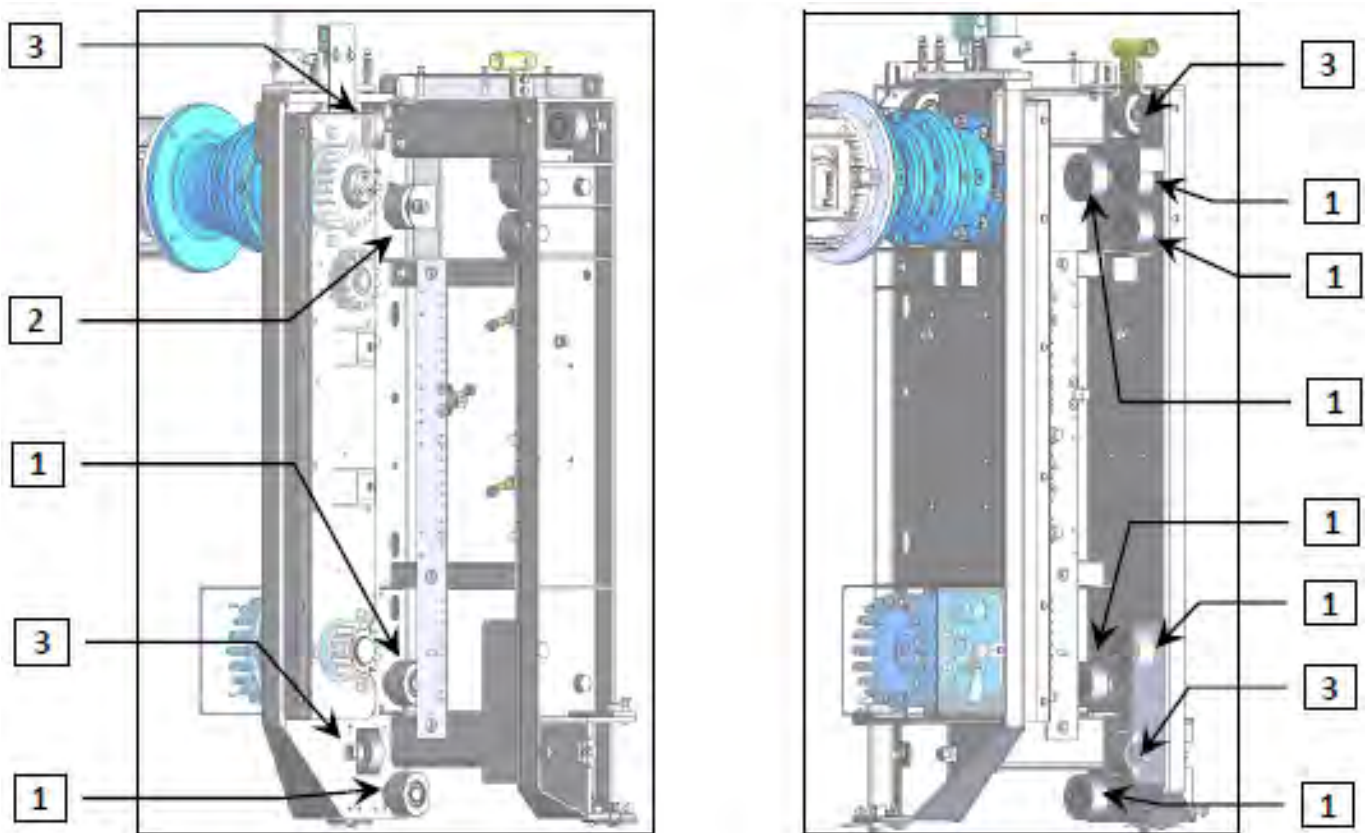
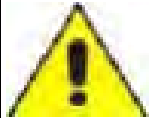

Figure 11.4

Item	Description	
1	Front and rear mast guide rollers	
2	Leaf spring (back-up) guide roller	
3	Side mast guide rollers	

ATTENTION:

Lock all guide rollers and their supports using the hardware affixed to them to prevent components from coming loose and/or falling off the machine during normal use.

ATTENTION:

Check all bearings within the guide rollers.
Some may be hidden.

11.3.3.1 Inspection of nylon guide rollers

Verify the guide roller measurements as follows:

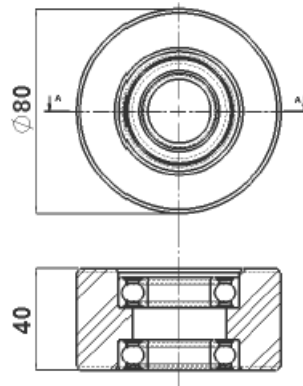
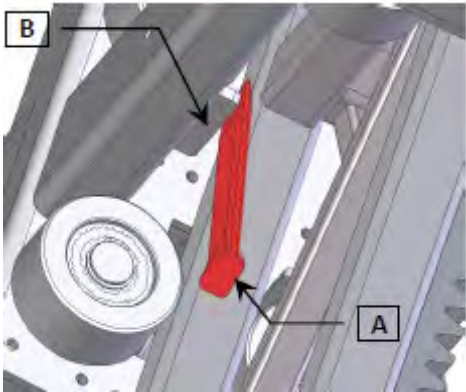
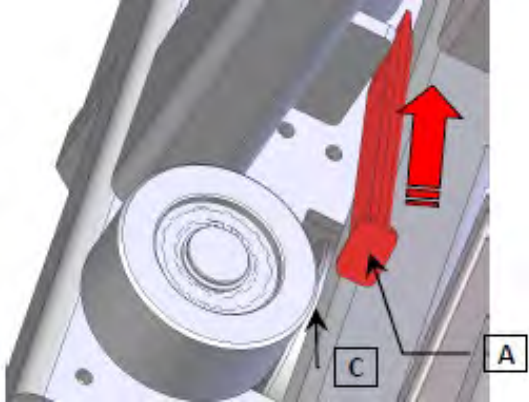
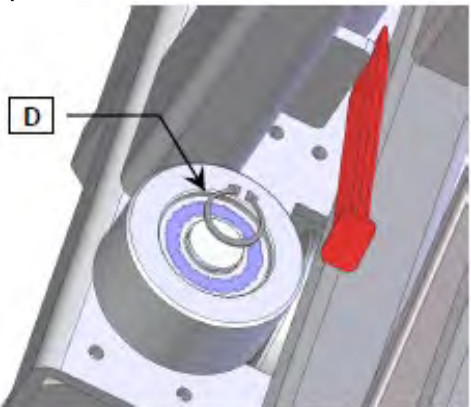
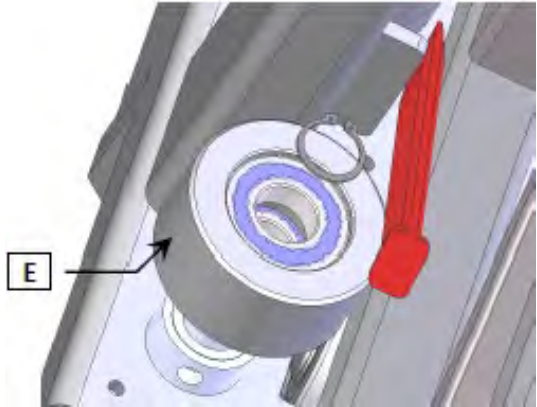
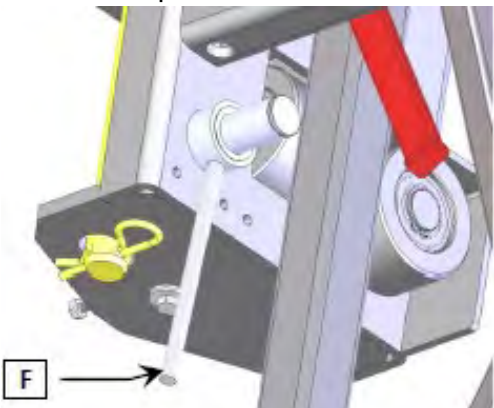
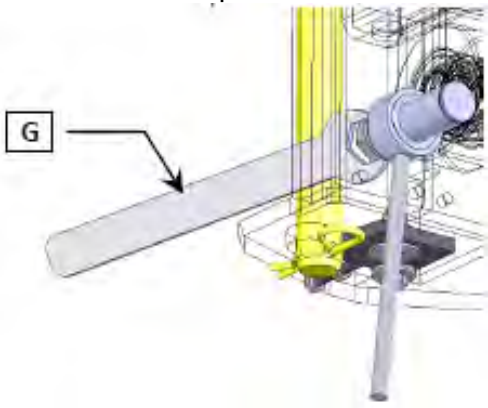

Figure 11.5

11.3.3.2 Replacement and adjustment of front/rear guide rollers

The tension on the guide rollers close to the mast must be released before servicing. Follow the procedure below.

<p>1) Insert a cold chisel or prybar (A) between mast and guide roller safety plate (B).</p> 	<p>2) Using a hammer, lightly tap the chisel (A) until the roller is 1-2mm from the mast (C).</p> 
<p>3) Remove the retaining clip (D) that is affixed to the pivot.</p> 	<p>4) Remove the guide roller (E) and replace with a new one.</p> 
<p>The below is for replacing the pivot shaft do to wear:</p>	
<p>5) Insert a dowel of 11-12mm diameter (F) into the hole on the pivot to lock it.</p> 	<p>6) Use the appropriate wrench (G) to unscrew the bolt that affixes the pivot.</p> 

When the roller is reinstalled, return the lifting unit to its original orientation. Check the vertical alignment of the motor to the mast to ensure proper gear mesh.

11.3.3.3 Replacement and adjustment of the rack leaf spring guide roller

The support plate must be removed to replace this roller. Follow the procedure below.

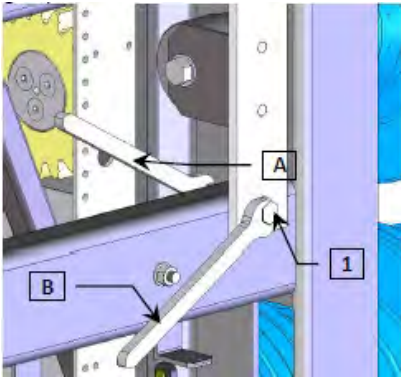
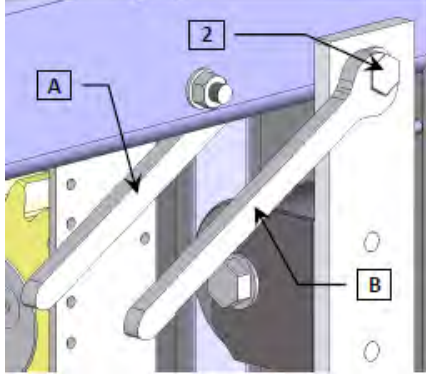
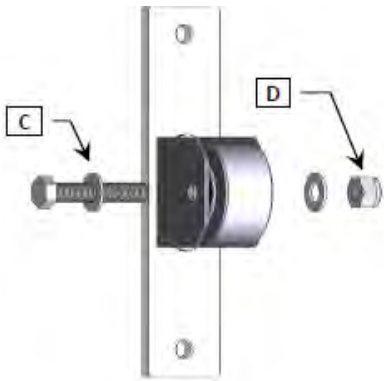
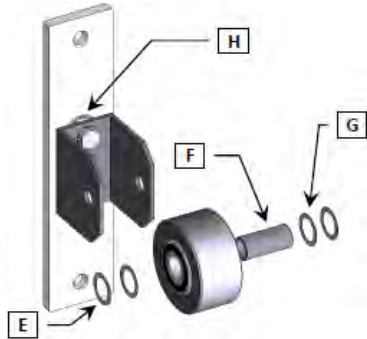
<p>1) Using two wrenches (A) and (B), loosen the bolts that affix the support plate to the lifting unit. Remove the bolts.</p> 	<p>2) Remove the second bolt in the same manner as step 1.</p> 
<p>3) Disassemble the guide roller from its support by removing the bolt (C) and self-locking nut (D).</p> 	<p>4) Remove the roller from its pivot, paying attention to the placement of the spacer washer (E) and (G). The remove the bushing (F) if needed.</p> 

To reassemble the leaf spring, reassemble the guide roller first and then:

- Insert bolts (1) and (2) from above and tighten until nut is touching support plate.
- Tighten the upper bolt (2) until tight.
- Tighten the lower bolt (1) until the leaf spring is slightly curved.
- If when the lower bolt (1) is completely tight and the leaf spring is not curved, it is necessary to add a washer behind each bolt that holds the bracket (H).
- Test the movement of the machine and verify the machine does not make any vibration during the decent cycle.
- If needed, tighten the lower bolt (1) a bit at a time until vibration ceases.

11.3.4 Verification and adjustment of the air gap of the motor brakes

The air gap (1) is the distance between brake electromagnet (2) and the brake pressure plate (3); one of which is set on the mobile anchor (4) of the device. In order to avoid vibrations on the anchor itself, excessive noise, the electromagnet's coil from burning or the braking unit from being damaged, this distance must be between 0.4 mm (0.015 in) and 0.6 mm (0.024 in). If the motor brake does not unlock or reaches its scheduled inspection, check the thickness of the brake lining and measure the air gap as described below:

- drive the cabin to the shutdown position on the ground floor level and disconnect the electrical control panel from the power line
- from the rear end of the lifting unit, remove the external protection cover (5) of the motor brakes after having removed the screws (6)
- check the measurement of the brake lining (7) with a caliber (>7.5 mm (0.295 in))
- check the measurement of the air gap (1) with a feeler gauge
- to adjust the measurement of the air gap (1), remove the motor counter-balance (8)
- loosen the jam nuts (9)
- act upon the bolts (10) that set the electromagnet in place by making it move close to or away from the mobile anchor (4) of the device
- implement this adjustment on all the bolts of the spring system and finally verify that the distance of the the air gap (1) is uniform on all the circumference
- before tightening the jam nuts (9), ensure the brake lever gap (11) is 0.7 mm (0.028 in)
- after adjusting the brake lever gap, re-check the adjustment on all the bolts (10) of the spring system and finally verify that the distance of the air gap (1) is uniform on all the circumference
- tighten the jam nuts (9)
- re-install the motor counterbalance (8)
- put the external protection cover (5) back on, fixing them in place with the screws (6)

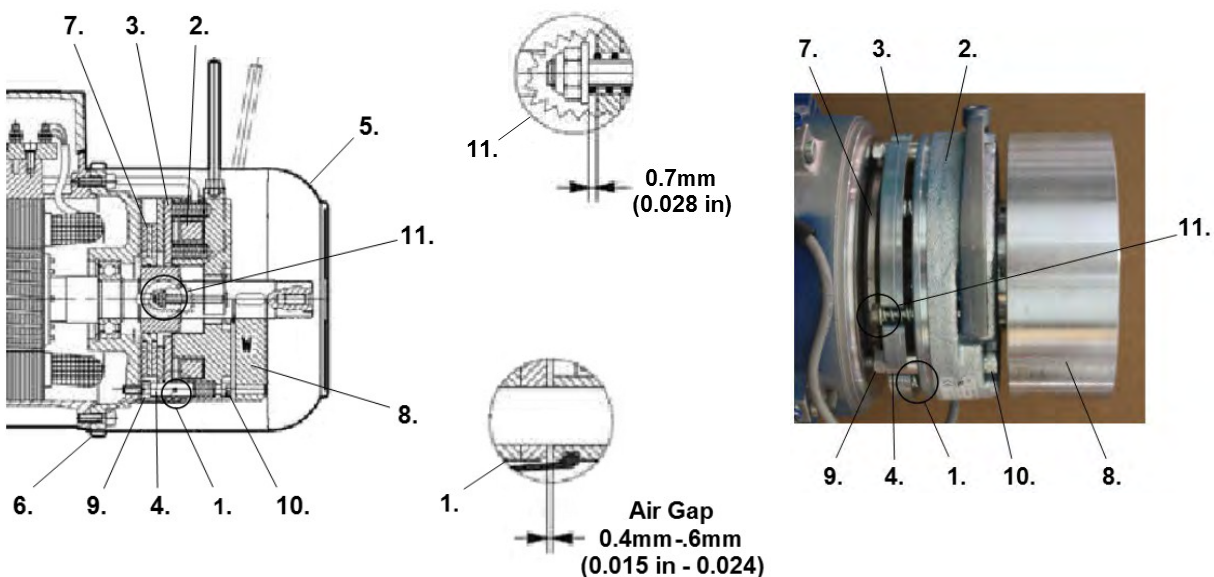

Figure 11.6

11.3.5 Servicing the gear motors

Servicing the gear motor installed on the machine simply requires the oil level to be checked - topping it off or replacing it if necessary, and in accordance with the schedules given below.

To carry out such operations proceed as described below:

- drive the cabin to the shutdown position on the ground floor level and disconnect the electrical control panel from the power line
- from the rear end of the lifting unit verify the oil level of the gear motor
- if the gear motor is equipped with a sight glass (1) simply ensure that the oil reaches the sight glass itself; if the gear motor is not equipped with a sight glass but has a level plug (2), remove this and ensure that the oil reaches the plug hole. If the oil cannot be seen, use a clean rod which is quite flexible and insert it in the plug hole in order to have a good idea on the level of the oil
- unscrew the oil filler cap (3) and add enough oil to reach the required level with SHELL OMALA S4 GX 320 oil or its equivalent
- the level plug (2) and the filler cap are to be screwed back on (3)

ATTENTION:

To service the gear motors correctly, the oil has to be completely replaced after the first 100 operating hours, then replaced after approximately 2000 operating hours and in any case, once a year and the oil level has to be checked every 500 operating hours.

Apart from the normal inspection of the oil level in accordance with the schedules given, the operator or authorized and qualified personnel will be responsible to carry out the maintenance, change the oil after the running-in period and replace all the oil in accordance with the stipulated schedule.

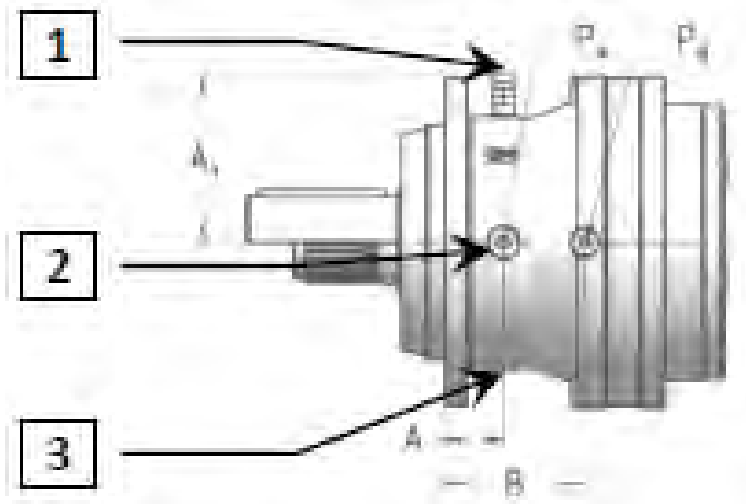

Figure 11.7

After about 100 operating hours, when the gear motor ends its running-in period, remove all the oil by removing the drain plug (4, fig. 11.6), wash the internal parts well and refill the tank with oil in accordance with the table below. The gear motor oil replacement must be carried out after 2000 operating hours or after one year. With every replacement, it is always best to wash the internal parts well.

Use lubricating oil which is of one of the following lubricants depending on the ambient temperature.

ATTENTION:

For any top-ups of lubricating oil between one replacement and another, always use the same type of oil found inside the gear motor.

DANGER:

The oil must be replaced when the gear motor is hot, therefore you must be careful not to burn yourself during this operation.

The lubricant that corresponds to the above-mentioned characteristics can be chosen from the listed below:

Table 11.1

MANUFACTURER	TEMPERATURE	
	-4°F / 113°F (-20°C / 45°C) ISO 3448VG 150-220	-4°F / 41°F (-20°C / 5°C) ISO 3448 VG 100
AGIP	BLASIA S 220	BLASIA 100
ARAL	DEGOL GS 220	DEGOL BG 100
BP MACH	SGR XP 220	GR XP 100
CASTROL	ALPHA SN 6	ALPHA SP 100
ELF	ORITIS 125 MS	REDUCTELF SP 100
	SYNTERMA P30	---
ESSO	COMPRESSOR OIL LG150	SPARTAN EP 100
I.P.	TELESIA OIL 150	MELLANA 100
MOBIL	GLYGOYLE 22	---
	GLYGOYLE 30	---
	SHC 630	---
SHELL	---	OMALA OIL 100
TOTAL	---	CARTER EP 100 N

ATTENTION:

It is absolutely prohibited to dispose of used oil in the environment.

11.3.6 Lubricating the machine

The machine must be lubricated carefully, paying particular attention to the areas affected by the motor transmission, such as between the pinions, pulleys (if presents) and the rack. Proceed as described below to lubricate the machine:

- from the rear end of the lifting unit, with the use of a brush, grease the pinions, the pulleys (if presents) and the rack, which can be reached from the ground. The grease used for lubrication must be adequate for outdoor conditions
- start-up the machine and turn the machine mode key switch to “ERECTION” position and the control mode key switch to “CABIN ONLY” so that the machine can be solely controlled by the operator who is responsible for maintenance
- from the loading unit, the maintenance technician must lubricate the various sections of the rack on each component of the vertical mast, as indicated earlier on, while controlling the upward movement of the lifting unit
- a small amount of grease must be inserted into the grease nipple located on the swing arm of the safety device after every drop test for lubrication of the swing arm shaft

DANGER:

While carrying out the inspection and lubrication, be very careful not to place your hands near the motor transmission when the cabin is moved; the risk of having your limbs, and particularly your hands, pinched or sheared, is very evident.

ATTENTION:

The necessity to carry out the lubrication process depends on a number of factors, such as how frequent the machine is used, the type of use of the machine (transporting modest loads or operating often with a full load) and also weather conditions / the elements of the place where it is installed.

It is of fundamental importance that the pinions, pulleys (if presents) and rack are lubricated well to avoid excessive wear and tear on the motor transmission system and to have a smoother drive with little noise and without excessive vibrations.

The lubricating process must be carried out every time the machine's movement causes too much vibration and excessive noise, as it becomes a necessity in both instances, even if it is still early for the scheduled lubrication process to be carried out.

ATTENTION:

When on the machine is installed the mast automatic greasing device, the operator only needs to supply the grease into the container of the device before its empty.

11.3.7 Calibration of the OVERWEIGHT SENSOR system

The overweight sensor system needs to be inspected for proper functionality. It may be necessary to re-calibrate the system. To re-calibrate the overweight sensor system, follow the instructions located in appendix G of this manual.

For any other assistance contact Beta Max technical support.

11.3.8 Inspection of the base jacks

Inspect the base jack legs for the below:

- The correct tightening of the lateral (L) and central (C) jacks
- Check for cracks on the structure or on the support pad
- If rust is present, treat effected area with anti-rust product

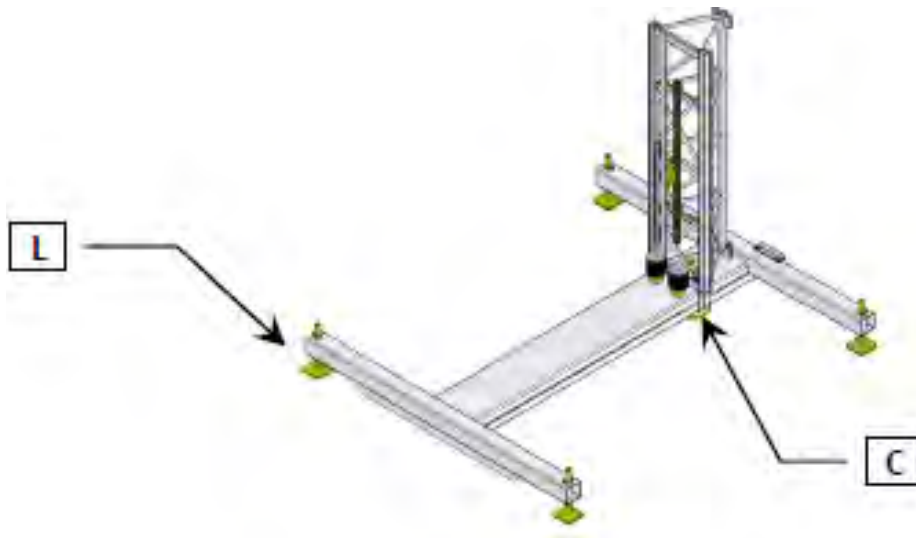

Figure 11.8

11.3.8.1 Inspection of the safety buffers

Check that the safety buffers (A) are in good condition, absent of cracks and with the plates (B) for load distribution. If the material is cracked or worn, replace with new parts or at intervals every 4 years.

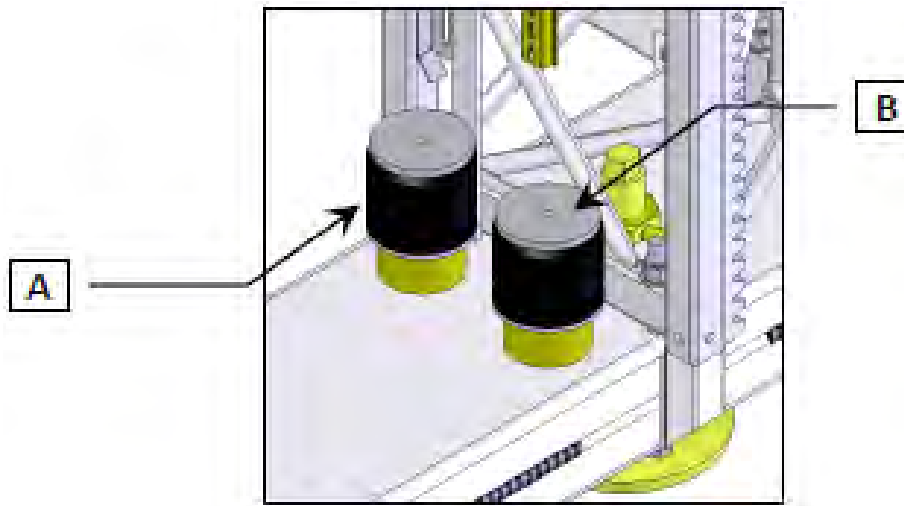

Figure 11.9

11.3.9 Inspection of cable guides

Check that the cable guide springs or fingers (A) are intact and in good condition. Verify the correct tightening on the mast, clamps (B). If rust is present, protect with an anti-rusting agent.

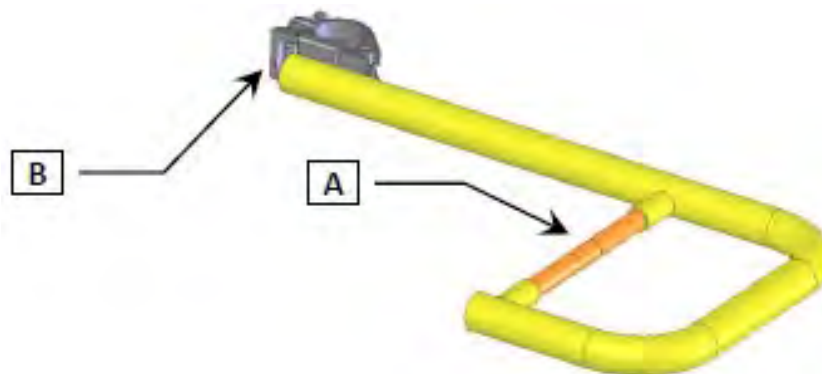

Figure 11.10

11.3.10 Inspection of the trailing cable

Inspect the trailing cable for damage due to debris or continuous movement. Replace the trailing cable as soon as possible to prevent loss of insulation with risks of exposed electrical conductors.

The trailing cable needs replaced when:

- There are bumps in different points of the cable (A)
- The cable seems to be twisted with many curves (B)

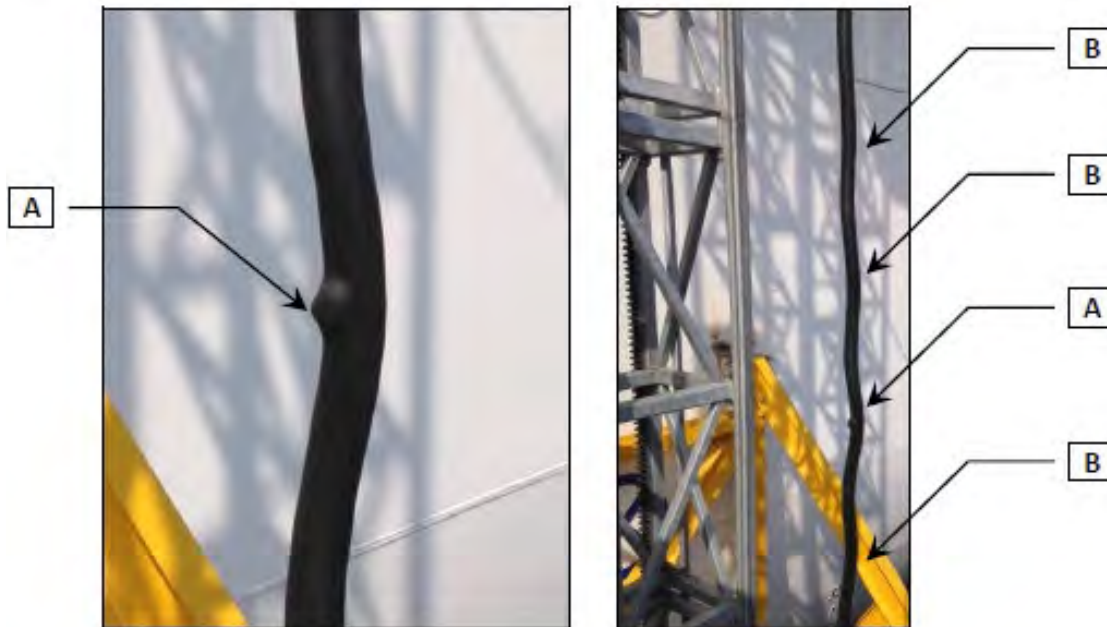

Figure 11.11

11.3.11 Inspection of automatic greaser

The machine is equipped with an automatic greaser pump located on the rear of the loading unit. This pump, when turned on, distributes grease on the rack during the UP cycle of the machine.

The greaser is supplied with an EP lithium-soap thickened grease with a higher power of adhesiveness.

A:
 Pump connection cable:
 — Brown wire and black wire (24VAC power supply)
 — Orange wire and green wire unused in this system

B:
 The minimum level of grease contained in the pump is about 1 cm from the bottom of the transparent tank.

C:
 Grease must be added via the connector (C), placed under the pump. Use of a grease gun is recommended.

D:
 Maximum fill level is about 1 cm from the top of the transparent tank.

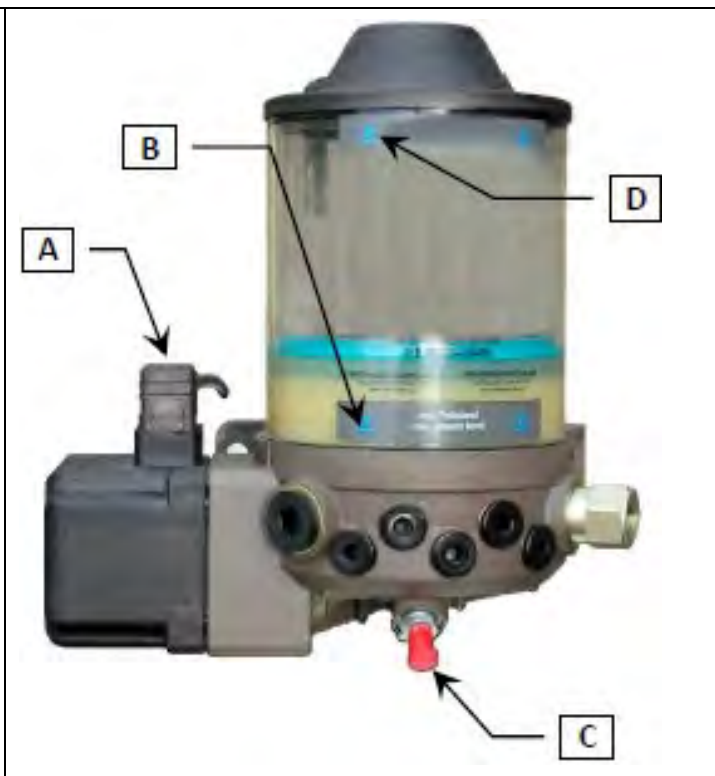

When the grease switch is enabled by the use of the keyed switch on the loading unit control panel, the automatic greaser dispenses grease during the up cycle of the machine.

Always check that there are no leaks in the pipefittings (E).

In case of tubing rupture, switch grease pump off, and replace tubing as soon as possible. The tube has a diameter of 3x6mm.

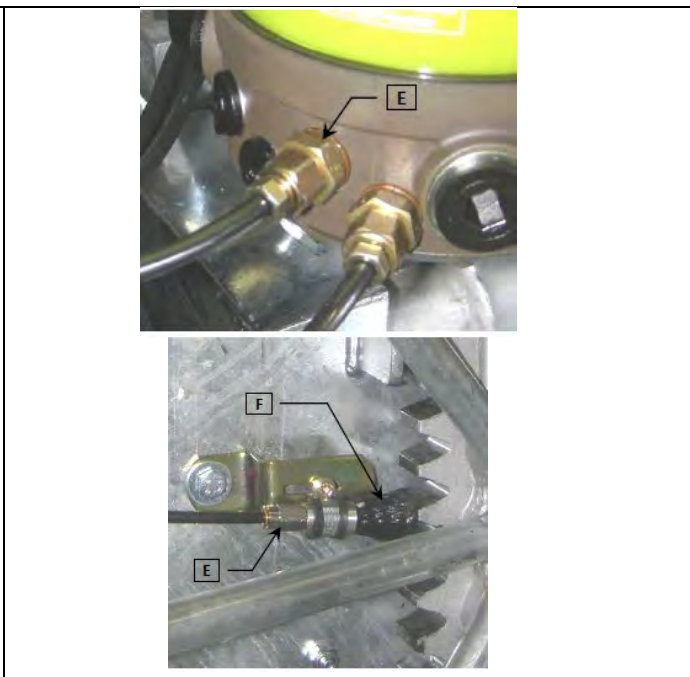

11.4 TESTING THE SAFETY BRAKE DEVICE

ATTENTION:

The drop test must be carried out upon every new installation and in conformity with local safety regulations that are in force. Moreover, this test must be carried out at least every 3 months (90 days) with at least a full load.

If the safety device intervenes during normal downward operation, or if abnormal noise is emitted while the cabin is being driven, the machine must be stopped immediately, and BETA MAX technical support must be contacted.

DANGER:

There must be nobody in the cabin when the drop test is carried out. Moreover, it is necessary to ensure that the brakes of the motors work well, as described earlier on.

DANGER:

The drop test must be carried out solely by personnel who has been adequately prepared or by BETA MAX technical support.

11.4.1 Performing the drop test

Proceed as described below to carry out the drop test:

- set the main switches on the base control panel and on-board control panel to the “OFF” position
- locate the DROP TEST PENDANT
- remove the jumper plug and connect the cable of the DROP TEST PENDANT to the onboard control panel

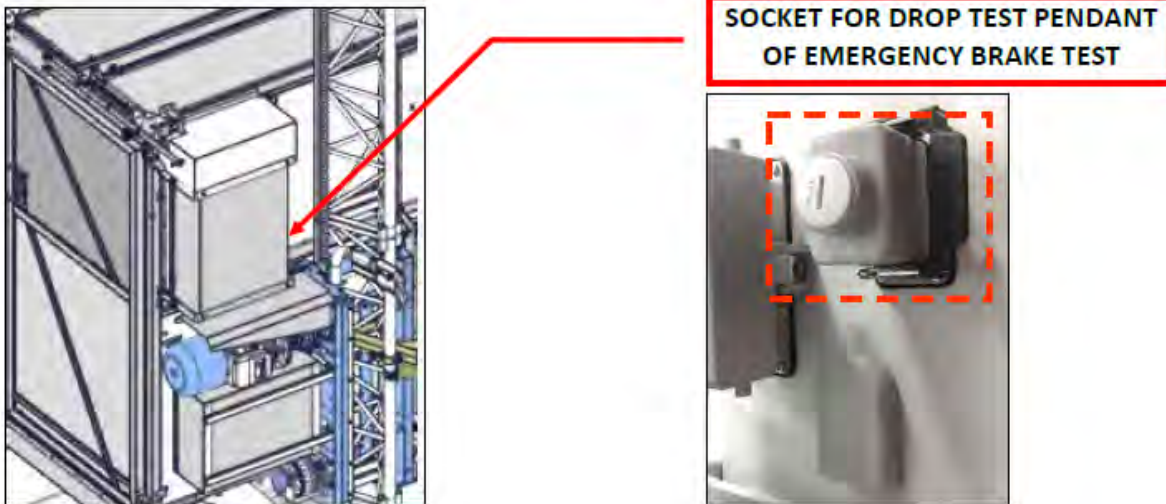

Figure 11.12

- run the DROP TEST PENDANT outside of the cabin and outside the ground enclosure to the ground, ensuring that the cable is suspended and that there is no risk of it being damaged during the drop test
- locate the OVERWEIGHT CONTROLLER SENSOR, remove the enclosure cover to retrieve the bypass fuse
- insert the bypass fuse into the fuse holder on the bottom of the OVERWEIGHT SENSOR controller enclosure and re-install the enclosure cover
- set the machine mode key switch to “ERECTION”
- set the control mode key switch to “CABIN & GROUND”
- test the machine at full rated load evenly distributed
- set the main switches on base control panel and on-board control panels to “ON” position
- close all doors
- using the drop test push button, drive the loading unit to a height of 20 ft, position the bottom of the machine at a point where 2 mast sections meet
- after making sure the area is clear of hazards, press the TEST button, this will release the electric motor brake, allowing the machine to descend by gravity; when the machine reaches a speed of about 138 ft/min, the safety brake will intervene, and the machine will stop. If the safety brake does not intervene, let go the TEST button immediately; this causes the motor brake to intervene immediately

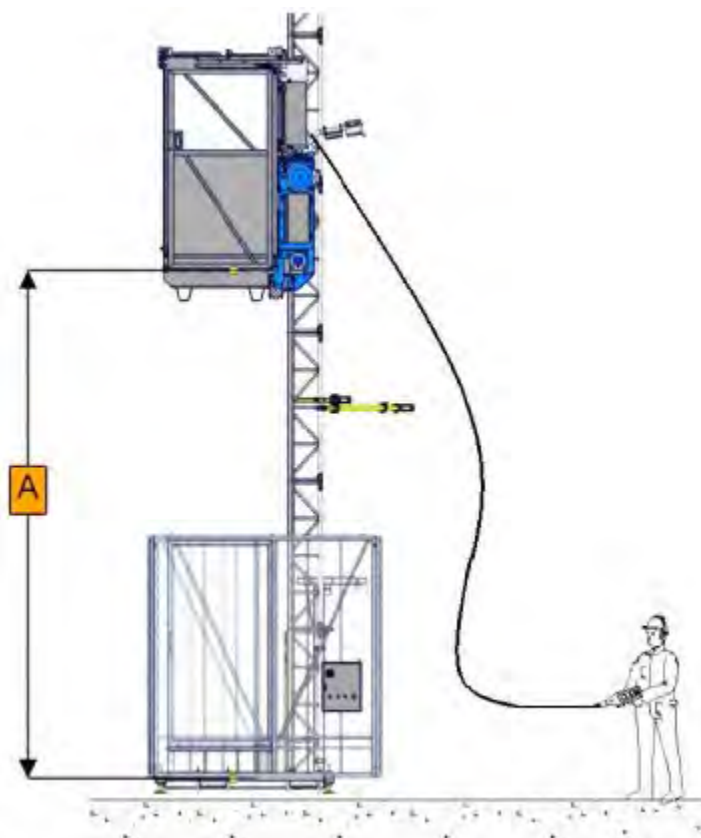

Figure 11.13

ATTENTION:

If the safety brake does not intervene because the cabin does not gain the required speed, let go the TEST button immediately; this causes the motor brake to intervene immediately, which in turn stops the cabin. Not letting go of the TEST button immediately, can cause a collision on the shock absorbing systems of the base unit.

NOTE:

Keep the TEST button pressed until the safety brake intervenes; when the cabin is at a standstill, drive the cabin in the upward direction for a very short distance, by pressing the relative button for a very short while; this releases the safety brake system, which is used later on for other resetting operations.

The safety device needs to be reset before returning the machine to its normal operation in a construction site.

11.4.2 Resetting the safety brake device

If the safety brake intervenes during normal operation, specifically trained personnel must inspect the motor brake, the transmission, the pinion, the rack, the guides and the rollers.

The cause must be identified and eliminated before the safety device is re-activated.

The above-mentioned inspection may be omitted only if the safety brake device has been activated as a result of a drop test.

Proceed as described to reset the safety device:

- after the machine has come to a complete stop, drive the machine up 5 ft. using the DROP TEST PENDANT
- return the machine to the ground level
 - if the machine is equipped with operations from the ground controls by using a trailing cable with power conductors and control conductors, after driving the machine up with the DROP TEST PENDANT, the machine can be driven down to ground level by the DOWN pushbutton on the base control panel
 - if the machine is only equipped with a trailing cable with power conductors, then ground controls are not available. After driving the machine up with the DROP TEST PENDANT, the machine can be brought down by pressing the TEST button for short instances to drive the machine to the ground level in short distances
- remove the weight from the machine
- set the main switches on the base control panel and on-board control panel to the “OFF” position
- remove the enclosure cover of the OVERWEIGHT SENSOR controller
- remove the bypass fuse from the fuse holder on the bottom of the OVERWEIGHT SENSOR controller enclosure
- re-fasten the by-pass fuse in the OVERWEIGHT SENSOR controller enclosure and re-install the cover
- remove the cable of the DROP TEST PENDANT from the onboard control panel and re-install the jumper plug
- set the main switches on base control panel and on-board control panels to “ON” position
- operate the machine in the up direction for about 10 ft. and return to the ground level by operating machine in the down direction
- lubricate the swing arm shaft by inserting a small amount of grease in the grease nipple

ATTENTION:

The safety brake device must be checked every 3 years at BETA MAX. The review date is stamped on the plate of each parachute (safety device).

After having carried out the procedures described, the machine is ready for its normal operation in a construction site.

11.4.3 Maintenance of the safety device

Lubricate the ratchet arm pivot point using a liquid lubricant such as WD40 in the ballpoints filler (A), clean from dirt if necessary.

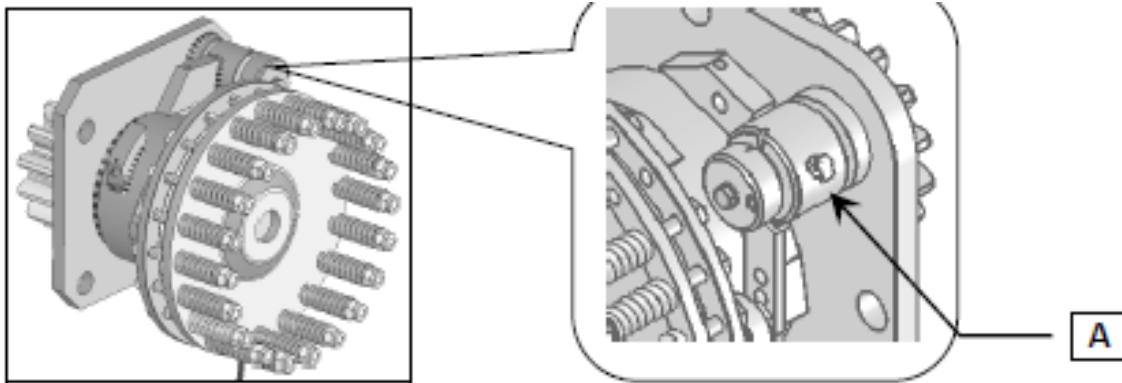

Figure 11.14

Check the safety device pinion gear for wear by following the below procedure:

- Position one 20mm round dowel between the pinion teeth as shown below. The external measurement must be about 131.5mm. If the measurement is less than 130mm correct the clearance or replace the pinion gear.
- This pinion must not be press forced into the rack on the mast. There should be a light gap.

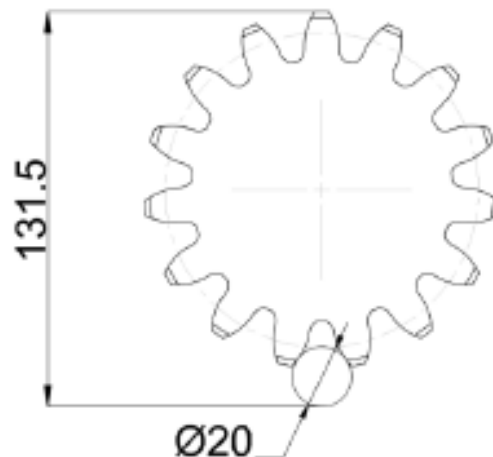

Figure 11.15

The safety device must be inspected and tested after each intervention during normal working phase and according to the maintenance and inspection periods outlined in Section 11.2.

11.5 ELECTRICAL SYSTEM MAINTENANCE

Inspection and maintenance operations of the electrical system will be carried out with the supply voltage disconnected but some troubleshooting will require the supply voltage to be connected.

A copy of the wiring diagram of the safety circuits must be kept near the electrical control panel.

DANGER:

Before accessing the internal part of the electrical control panel 15 minute after it has been disconnected, so that all circuits can dispel their residual energy.

11.5.1 Maintenance of the electrical system rectifiers

For correct verification of the installed live rectifiers, use a multi-meter and proceed as described below:

- measure the continuous DC voltage between terminals (+) and (-) and the AC voltage between the terminals marked with the appropriate symbol (~)
- verify that the DC voltage value at the correct valve as stated on the rectifier labeling
- check the rectifier diodes, verifying continuity between the marked clamps on the diode with disconnected from its power supply
- verify that the diodes do not allow the current to pass in one direction and when the probes of the measuring instrument are inverted, the current is allowed to pass in the opposite direction. Residual resistance, detected in the flowing direction of the current, is caused by the threshold voltage of the diodes
- verify the resistance value between the terminals (+) and (-) of the rectifiers. There must be no connection when verifying the diode quality

NOTE:

In order to carry out such maintenance, refer to the wiring diagram that is placed near the electrical control panel.

ATTENTION:

It is obligatory that only specialized and authorized personnel or BETA MAX technical support carry out all inspection and repair operations on the installed rectifiers.

11.5.2 Location of limit switches

1. Roof hatch switch
2. Door limit switch
3. Door lock limit switch
4. Anti-tear limit switch
5. Erection platform limit switch
6. Safety device limit switch
7. Auxiliary limit switch
8. Up stop limit switch
9. Upward slowdown limit switch
10. Down stop limit switch
11. Downward slowdown limit switch
12. Up over-travel limit switch
13. Down over-travel limit switch

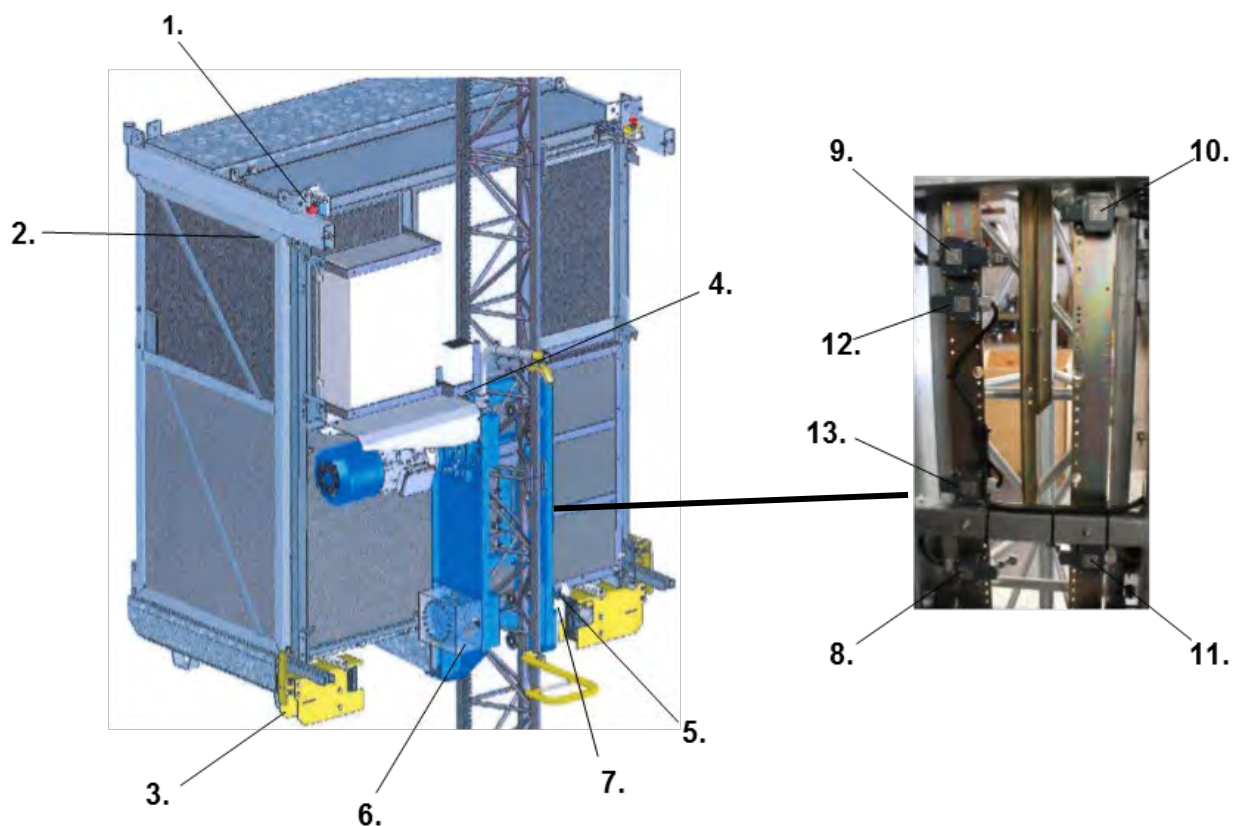

Figure 11.16

11.5.3 Inspection of braking resistors

For motors controlled by a variable frequency drive (VFD), it is necessary to inspect the braking resistors mounted on the bottom of the loading unit.

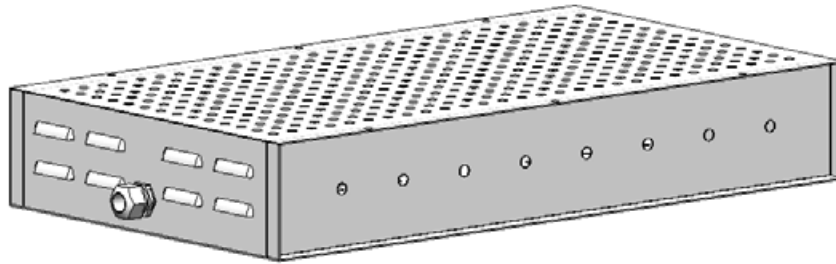

Figure 11.17

- Visually check each resistor to verify it is in good physical condition and free of dirt
- Measure the total resistance value (ohms) corresponding to the value shown in the electrical schematic (at temperature of 20°C or 68°F). If the value differs more than 5% from the value given, one or more resistors may be damaged. In this case, proceed with checking the resistors one by one.

11.6 TECHNICAL SUPPORT

Technical support for the machine is provided directly by the BETA MAX Company by calling or sending a fax to the numbers below:

Ph. 321-727-3737

TF. 800-233-5112

Fax 321-768-9517

This page has been left blank for formatting purposes

CHAPTER 12: WARRANTY

Record of modifications

Revision	Executor	Date	Description of modification

12 WARRANTY

12.1 WARRANTY

Beta Max, Incorporated warrants all MAX CLIMBER RACK & PINION HOISTS to be free from defects in material and workmanship under normal use and service provided it has been maintained as specified in the owner’s manual.

Beta Max, Incorporated will provide to the original purchaser** a 12-month limited warranty on all parts excluding those parts whose warranty schedule is listed below. Our obligation under this warranty, as outlined below, is limited to repairing or replacing, at our discretion, any part of the unit, which proves upon examination to be defective in material or workmanship. The item is to be returned to Beta Max, Incorporated through an authorized distributor. The warranty period below is from the date that the equipment is sold to the original purchaser**. All return shipments must be prepaid by the customer.

<u>Limited High Wear Items:</u>	<u>Warranty</u>
<ul style="list-style-type: none"> - Lights and Service Outlets - Limit Switches - Landing and Car Door Rollers & Cable - All Electrical Components 	90 Days
<u>Extended Warranty Items:</u>	<u>Warranty</u>
<ul style="list-style-type: none"> - Motor and Motor Brake Assembly - Transmission/Gearbox 	2 Years
<ul style="list-style-type: none"> - Base Frame - Mast 	5 Years
<ul style="list-style-type: none"> - Emergency Brake (Safety Device) <p>(good for the extent of the brake certification period)</p>	3-5 Years

** “Original Purchaser” definition: for rental machines: Dealer,
 for resale machines: First User.

Any parts proven to be defective upon our inspection will be repaired or replaced at no cost. The obligation under this warranty includes freight costs if determined the product failed under normal usage within the above-described time.

The manufacturer reserves the right to have the warranty serviced by the distributor from whom the unit was purchased. The distributor will make arrangements with the factory for repairs or replacement of parts within the terms of this warranty. Distributors must get a return authorization number from Beta Max before any item is returned for repairs or replacement.

Beta Max, Incorporated's obligation is limited to replacing parts and does not include replacing the complete unit. This warranty is void on any unit that has been modified or tampered with, repaired by persons other than a factory representative or an authorized Beta Max distributor, repaired with other than Beta Max standard parts, or damaged by reasons of accident, alteration, misuse or abuse.

This warranty is in lieu of all other warranties, expressed or implied. We do not authorize any person or representative to make any guarantee or to assume for us any liability in connection with the sale of our products other than those contained herein. Any agreement outside of or contradictory to the foregoing shall be void and of no effect.

This page has been left blank for formatting purposes

Appendix A

Installation Data Sheet Form (Section 6.2)

This page has been left blank for formatting purposes



1895 Robert J. Conlan Blvd NE
Palm Bay, FL 32905
Ph. (800) 233-5112
Fax (321) 768-9517
www.betamaxhoist.com

Installation Data Sheet Form

MC2000PMB V

PROJECT NAME: _____

PROJECT ADDRESS: _____

SITE MANAGER: _____

Machine Installation Type: PERSONNEL HOIST

Serial Number: _____

Unit Weight: _____

Max Height: _____

Max Load: _____

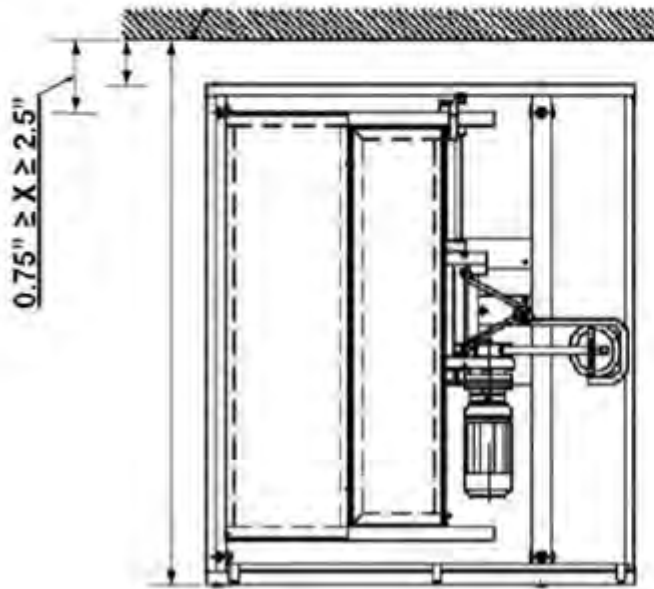

Machine Placement

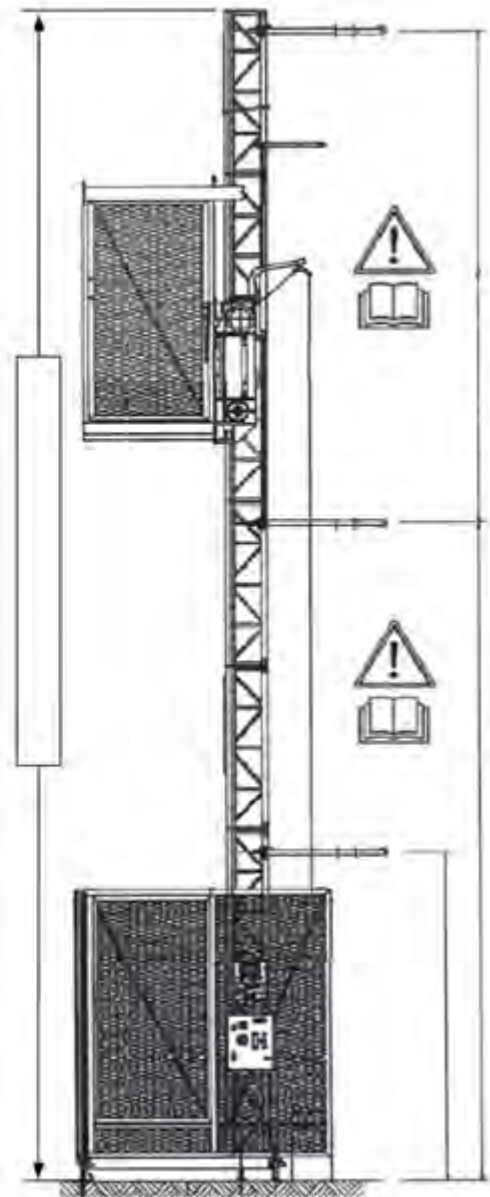

Anchorage Placement

Appendix B

Verification and Test Data Sheet Form (Section 6.4)

This page has been left blank for formatting purposes



1895 Robert J. Conlan Blvd NE
 Palm Bay, FL 32905
 Ph. (800) 233-5112
 Fax (321) 768-9517
www.betamaxhoist.com

Verification and Test Data Sheet

MC2000PMB V

SECTION I – VERIFICATION OF DAMAGE DUE TO TRANSPORTATION

Note: If any item is marked DAMAGED, write comments in the notes section.

	OK	DAMAGED	N/A
1. BASE UNIT.....	<input type="checkbox"/>	<input type="checkbox"/>	<input type="checkbox"/>
2. LIFTING UNIT.....	<input type="checkbox"/>	<input type="checkbox"/>	<input type="checkbox"/>
3. LOADING UNIT.....	<input type="checkbox"/>	<input type="checkbox"/>	<input type="checkbox"/>
4. ELECTRICAL CONTROL PANELS (BASE AND ONBOARD THE MACHINE).....	<input type="checkbox"/>	<input type="checkbox"/>	<input type="checkbox"/>
5. BASE ENCLOSURE AND ACCESS DOOR.....	<input type="checkbox"/>	<input type="checkbox"/>	<input type="checkbox"/>
6. CONTROL AND POWER ELECTRICAL CABLES.....	<input type="checkbox"/>	<input type="checkbox"/>	<input type="checkbox"/>
7. MAST.....	<input type="checkbox"/>	<input type="checkbox"/>	<input type="checkbox"/>
8. WALL ANCHORS.....	<input type="checkbox"/>	<input type="checkbox"/>	<input type="checkbox"/>
9. CABLE GUIDES AND DRUM.....	<input type="checkbox"/>	<input type="checkbox"/>	<input type="checkbox"/>
10. FLOOR-LEVEL SAFETY DEVICES (DOOR/GATES).....	<input type="checkbox"/>	<input type="checkbox"/>	<input type="checkbox"/>
11. FLOOR-LEVEL CALLING DEVICES (IF PRESENT).....	<input type="checkbox"/>	<input type="checkbox"/>	<input type="checkbox"/>

SECTION II – VERIFICATION OF MACHINE MISSING COMPONENTS

Note: If any item is marked MISSING, write comments in the notes section.

	OK	MISSING	N/A
1. MAST.....	<input type="checkbox"/>	<input type="checkbox"/>	<input type="checkbox"/>
2. WALL ANCHORS.....	<input type="checkbox"/>	<input type="checkbox"/>	<input type="checkbox"/>
3. CONTROL AND POWER ELECTRICAL CABLES.....	<input type="checkbox"/>	<input type="checkbox"/>	<input type="checkbox"/>
4. BRAKING DEVICES AND PADS.....	<input type="checkbox"/>	<input type="checkbox"/>	<input type="checkbox"/>
5. CABLE GUIDES AND DRUM.....	<input type="checkbox"/>	<input type="checkbox"/>	<input type="checkbox"/>
6. FLOOR-LEVEL SAFETY DEVICES (DOOR/GATES).....	<input type="checkbox"/>	<input type="checkbox"/>	<input type="checkbox"/>
7. FLOOR-LEVEL CALLING DEVICES (IF PRESENT).....	<input type="checkbox"/>	<input type="checkbox"/>	<input type="checkbox"/>

SECTION III – VERIFICATION OF SAFETY EQUIPMENT

Note: If any item is marked FAIL, write comments in the notes section.

	PASS	FAIL	N/A
1. WEAR AND TEAR/USAGE OF THE MOTOR PINION.....	<input type="checkbox"/>	<input type="checkbox"/>	<input type="checkbox"/>
2. WEAR AND TEAR/USAGE OF THE GUIDE ROLLERS.....	<input type="checkbox"/>	<input type="checkbox"/>	<input type="checkbox"/>
3. WEAR AND TEAR/USAGE OF THE RACK TEETH ON THE MAST.....	<input type="checkbox"/>	<input type="checkbox"/>	<input type="checkbox"/>
4. WEAR AND TEAR/USAGE OF THE SAFETY DEVICE PINION.....	<input type="checkbox"/>	<input type="checkbox"/>	<input type="checkbox"/>
5. WEAR AND TEAR/USAGE OF THE ELECTRIC MOTOR BRAKE.....	<input type="checkbox"/>	<input type="checkbox"/>	<input type="checkbox"/>
6. SAFETY DEVICE EXPIRATION DATE.....	<input type="checkbox"/>	<input type="checkbox"/>	<input type="checkbox"/>
7. MECHANICAL INTERLOCKS OF THE ACCESS DOORS FOR THE LOADING UNIT AND THE BASE ENCLOSURE DOOR.....	<input type="checkbox"/>	<input type="checkbox"/>	<input type="checkbox"/>
8. MECHANICAL INTERLOCKS OF THE ACCESS DOORS/GATES AND BASE ENCLOSURE FOR THE FLOOR-LEVELS.....	<input type="checkbox"/>	<input type="checkbox"/>	<input type="checkbox"/>
9. EMERGENCY PUSHBUTTONS.....	<input type="checkbox"/>	<input type="checkbox"/>	<input type="checkbox"/>
10. UPWARD AND DOWNWARD OVERTRAVEL LIMIT SWITCH.....	<input type="checkbox"/>	<input type="checkbox"/>	<input type="checkbox"/>
11. UPWARD AND DOWNWARD OVERTRAVEL PAD.....	<input type="checkbox"/>	<input type="checkbox"/>	<input type="checkbox"/>
12. UP AND DOWN END-OF-TRAVEL LIMIT SWITCH.....	<input type="checkbox"/>	<input type="checkbox"/>	<input type="checkbox"/>
13. UPWARD AND DOWNWARD SLOWDOWN LIMIT SWITCH.....	<input type="checkbox"/>	<input type="checkbox"/>	<input type="checkbox"/>
14. UP AND DOWN END-OF-TRAVEL PAD.....	<input type="checkbox"/>	<input type="checkbox"/>	<input type="checkbox"/>
15. SAFETY DEVICE LIMIT SWITCH.....	<input type="checkbox"/>	<input type="checkbox"/>	<input type="checkbox"/>
16. ERECTION PLATFORM LIMIT SWITCH.....	<input type="checkbox"/>	<input type="checkbox"/>	<input type="checkbox"/>
17. LIMIT SWITCH FAR ACCESS DOORS FOR THE LOADING UNIT AND THE BASE ENCLOSURE DOOR.....	<input type="checkbox"/>	<input type="checkbox"/>	<input type="checkbox"/>

SECTION IV – VERIFICATION OF MACHINE CONTROLS

Note: If any item is marked FAIL, write comments in the notes section.

	PASS	FAIL	N/A
1. INCREASE FLOOR PUSHBUTTON.....	<input type="checkbox"/>	<input type="checkbox"/>	<input type="checkbox"/>
2. DECREASE FLOOR PUSHBUTTON.....	<input type="checkbox"/>	<input type="checkbox"/>	<input type="checkbox"/>
3. RUN OPERATOR PUSHBUTTON.....	<input type="checkbox"/>	<input type="checkbox"/>	<input type="checkbox"/>
4. FLOOR LEVEL LANDING SYSTEM.....	<input type="checkbox"/>	<input type="checkbox"/>	<input type="checkbox"/>
5. STOP NEXT FLOOR PUSHBUTTON.....	<input type="checkbox"/>	<input type="checkbox"/>	<input type="checkbox"/>
6. SEND TO GROUND PUSHBUTTON.....	<input type="checkbox"/>	<input type="checkbox"/>	<input type="checkbox"/>
7. OPERATION OF MANUAL LOWERING.....	<input type="checkbox"/>	<input type="checkbox"/>	<input type="checkbox"/>
8. LIMIT SWITCH FOR FLOOR-LEVEL SAFETY DEVICES (DOORS).....	<input type="checkbox"/>	<input type="checkbox"/>	<input type="checkbox"/>



Appendix C

General Maintenance (Daily) Checklist Form (Section 11.2.1)

This page has been left blank for formatting purposes



1895 Robert J. Conlan Blvd NE
 Palm Bay, FL 32905
 Ph. (800) 233-5112
 Fax (321) 768-9517
www.betamaxhoist.com

Operators Daily Checklist
MC2000PMB V

OPERATOR: _____ **DATE:** _____

SERIAL NUMBER: _____ **TIME:** _____

Note: If any item is marked FAIL, write comments in the notes section.

	PASS	FAIL	N/A
1. CHECK FOR FALLEN HARDWARE IN PIT AREA (e.g., MAST BOLTS, CABLE GUIDES).....	<input type="checkbox"/>	<input type="checkbox"/>	<input type="checkbox"/>
2. CHECK HOISTWAY FOR OBSTRUCTIONS.....	<input type="checkbox"/>	<input type="checkbox"/>	<input type="checkbox"/>
3. CHECK GREASE LEVEL IN AUTOMATIC GREASER.....	<input type="checkbox"/>	<input type="checkbox"/>	<input type="checkbox"/>
4. CHECK FOR ANY SIGNS OF OIL LEAKS AROUND GEARBOX AND MOTOR.....	<input type="checkbox"/>	<input type="checkbox"/>	<input type="checkbox"/>
5. CHECK EMERGENCY STOP PUSHBUTTONS AND MAIN SWITCHES.....	<input type="checkbox"/>	<input type="checkbox"/>	<input type="checkbox"/>
6. PERFORM TRIAL RUNS WITH THE EMERGENCY STOP PUSHBUTTONS ENGAGED TO VERIFY FUNCTIONALITY.....	<input type="checkbox"/>	<input type="checkbox"/>	<input type="checkbox"/>
7. PERFORM TRIAL RUNS WITH CAR DOOR/RAMP OPEN TO VERIFY UNIT DOES NOT RUN.....	<input type="checkbox"/>	<input type="checkbox"/>	<input type="checkbox"/>
8. CHECK THE FUNCTIONALITY OF THE CABIN LIGHT.....	<input type="checkbox"/>	<input type="checkbox"/>	<input type="checkbox"/>
9. CHECK THE CONTROLS ARE FUNCTIONING AND ARE UNDAMAGED.....	<input type="checkbox"/>	<input type="checkbox"/>	<input type="checkbox"/>
10. PERFORM A TRIAL RUN TO VERIFY MOTOR AND MOTOR BRAKE ARE FUNCTIONING.....	<input type="checkbox"/>	<input type="checkbox"/>	<input type="checkbox"/>
11. CHECK THE TRAILING CABLE, ENSURING ALL OF THE CABLE IS SPOOLED INTO THE CABLE DRUM.....	<input type="checkbox"/>	<input type="checkbox"/>	<input type="checkbox"/>
12. CHECK CABLE GUIDES FOR MISSING OR LOOSE HARDWARE.....	<input type="checkbox"/>	<input type="checkbox"/>	<input type="checkbox"/>
13. CHECK CABLE GUIDES FOR MISSING RUBBER KEEPERS.....	<input type="checkbox"/>	<input type="checkbox"/>	<input type="checkbox"/>
14. CHECK WALL ANCHORS FOR MISSING OR LOOSE HARDWARE.....	<input type="checkbox"/>	<input type="checkbox"/>	<input type="checkbox"/>
15. CHECK MAST SECTIONS FOR MISSING OR LOOSE HARDWARE.....	<input type="checkbox"/>	<input type="checkbox"/>	<input type="checkbox"/>
16. CHECK FUNCTIONALITY OF THE FINAL TRAVEL STOPS.....	<input type="checkbox"/>	<input type="checkbox"/>	<input type="checkbox"/>

COMMENTS: _____

SIGNATURE: _____



Appendix D

General Maintenance (40 hours) Checklist Form (Section 11.2.2)



This page has been left blank for formatting purposes



1895 Robert J. Conlan Blvd NE
 Palm Bay, FL 32905
 Ph. (800) 233-5112
 Fax (321) 768-9517
www.betamaxhoist.com

General Maintenance

40 Hours

MC2000PMB V

Note: If any item is marked FAIL, write comments in the notes section.

	PASS	FAIL	N/A
1. CLEAN THE CABIN FLOORING AND THE AREA AROUND THE MACHINE.....	<input type="checkbox"/>	<input type="checkbox"/>	<input type="checkbox"/>
2. ENSURE THAT ALL WARNING SIGNS ARE LEGIBLE AND IN THE RIGHT PLACE.....	<input type="checkbox"/>	<input type="checkbox"/>	<input type="checkbox"/>
3. ENSURE THAT ALL DOCUMENTS ARE READILY AVAILABLE AND LEGIBLE...	<input type="checkbox"/>	<input type="checkbox"/>	<input type="checkbox"/>
4. CHECK THE OIL LEVEL OF THE GEARBOX.....	<input type="checkbox"/>	<input type="checkbox"/>	<input type="checkbox"/>
5. LUBRICATE THE PINION SHAFT OF THE SAFETY DEVICE THROUGH THE PROPER GREASE NIPPLE.....	<input type="checkbox"/>	<input type="checkbox"/>	<input type="checkbox"/>
6. LUBRICATE THE INDICATED PARTS, PAYING PARTICULAR ATTENTION TO THE RACK.....	<input type="checkbox"/>	<input type="checkbox"/>	<input type="checkbox"/>
7. CHECK THE GREASE LEVEL OF THE AUTOMATIC GREASER.....	<input type="checkbox"/>	<input type="checkbox"/>	<input type="checkbox"/>
8. ENSURE ALL CONNECTIONS OF THE GUIDE ROLLERS TO THE MACHINE'S FRAME ARE CORRECT AND TIGHT.....	<input type="checkbox"/>	<input type="checkbox"/>	<input type="checkbox"/>
9. CHECK THE RACK OF THE MAST AND THE MOTOR PINION; ENSURE THERE IS NO DAMAGE, ALIGNMENT ERRORS, OR DEFECTIVE CONNECTIONS.....	<input type="checkbox"/>	<input type="checkbox"/>	<input type="checkbox"/>
10. ENSURE THAT THE ELECTRIC MOTOR BRAKE FUNCTIONS PROPERLY; THE LOADING UNIT MUST STOP WITHIN THE SET LIMITS WHEN THE BRAKE IS APPLIED.....	<input type="checkbox"/>	<input type="checkbox"/>	<input type="checkbox"/>
11. VISUALLY INSPECT THAT ALL BOLTED JOINTS BETWEEN THE COMPONENTS OF THE MAST ARE PRESENT.....	<input type="checkbox"/>	<input type="checkbox"/>	<input type="checkbox"/>
12. CHECK MAST TIES FOR MISSING OR LOOSE HARDWARE.....	<input type="checkbox"/>	<input type="checkbox"/>	<input type="checkbox"/>
13. CHECK CABLE GUIDES FOR LOOSE OR MISSING HARDWARE AND RUBBER KEEPERS.....	<input type="checkbox"/>	<input type="checkbox"/>	<input type="checkbox"/>
14. CHECK EMERGENCY STOP PUSHBUTTONS AND MAIN SWITCHES.....	<input type="checkbox"/>	<input type="checkbox"/>	<input type="checkbox"/>
15. CHECK THAT THE HOIST CONTROLS ARE FUNCTIONING AND ARE UNDAMAGED.....	<input type="checkbox"/>	<input type="checkbox"/>	<input type="checkbox"/>
16. PERFORM A TRIAL RUN WITH THE EMERGENCY STOP PUSHBUTTONS ENGAGED TO VERIFY FUNCTIONALITY.....	<input type="checkbox"/>	<input type="checkbox"/>	<input type="checkbox"/>
17. VERIFY THE OPERATION OF THE FINAL TRAVEL STOPS.....	<input type="checkbox"/>	<input type="checkbox"/>	<input type="checkbox"/>
18. ENSURE THAT ALL THE MECHANICAL AND ELECTRICAL SYNCHRONIZED SYSTEMS FUNCTION PROPERLY – BOTH ON THE MACHINE AND ON THE FLOOR LEVELS	<input type="checkbox"/>	<input type="checkbox"/>	<input type="checkbox"/>



Appendix E

General Maintenance (125 hours) Checklist Form (Section 11.2.3)

This page has been left blank for formatting purposes



1895 Robert J. Conlan Blvd NE
 Palm Bay, FL 32905
 Ph. (800) 233-5112
 Fax (321) 768-9517
www.betamaxhoist.com

General Maintenance

125 Hours

MC2000PMB V

Note: If any item is marked FAIL, write comments in the notes section.

	PASS	FAIL	N/A
1. CLEAN THE CABIN FLOORING AND THE AREA AROUND THE MACHINE.....	<input type="checkbox"/>	<input type="checkbox"/>	<input type="checkbox"/>
2. ENSURE THAT ALL WARNING SIGNS ARE LEGIBLE AND IN THE RIGHT PLACE.....	<input type="checkbox"/>	<input type="checkbox"/>	<input type="checkbox"/>
3. ENSURE THAT ALL DOCUMENTS ARE READILY AVAILABLE AND LEGIBLE...	<input type="checkbox"/>	<input type="checkbox"/>	<input type="checkbox"/>
4. CHECK THE OIL LEVEL OF THE GEARBOX.....	<input type="checkbox"/>	<input type="checkbox"/>	<input type="checkbox"/>
5. LUBRICATE THE PINION SHAFT OF THE SAFETY DEVICE THROUGH THE PROPER GREASE NIPPLE.....	<input type="checkbox"/>	<input type="checkbox"/>	<input type="checkbox"/>
6. LUBRICATE THE INDICATED PARTS, PAYING PARTICULAR ATTENTION TO THE RACK.....	<input type="checkbox"/>	<input type="checkbox"/>	<input type="checkbox"/>
7. CHECK THE GREASE LEVEL OF THE AUTOMATIC GREASER.....	<input type="checkbox"/>	<input type="checkbox"/>	<input type="checkbox"/>
8. ENSURE ALL CONNECTIONS OF THE GUIDE ROLLERS TO THE MACHINE'S FRAME ARE CORRECT AND TIGHT.....	<input type="checkbox"/>	<input type="checkbox"/>	<input type="checkbox"/>
9. CHECK THE RACK OF THE MAST AND THE MOTOR PINION; ENSURE THERE IS NO DAMAGE, ALIGNMENT ERRORS, OR DEFECTIVE CONNECTIONS.....	<input type="checkbox"/>	<input type="checkbox"/>	<input type="checkbox"/>
10. ENSURE THAT THE ELECTRIC MOTOR BRAKE FUNCTIONS PROPERLY; THE LOADING UNIT MUST STOP WITHIN THE SET LIMITS WHEN THE BRAKE IS APPLIED.....	<input type="checkbox"/>	<input type="checkbox"/>	<input type="checkbox"/>
11. TIGHTEN ALL BOLTED JOINTS BETWEEN THE COMPONENTS OF THE MAST.	<input type="checkbox"/>	<input type="checkbox"/>	<input type="checkbox"/>
12. TIGHTEN ALL BOLTED JOINTS OF THE WALL ANCHORS.....	<input type="checkbox"/>	<input type="checkbox"/>	<input type="checkbox"/>
13. TIGHTEN CABLE GUIDES AND CHECK FOR MISSING CABLE KEEPERS.....	<input type="checkbox"/>	<input type="checkbox"/>	<input type="checkbox"/>
14. CHECK EMERGENCY STOP PUSHBUTTONS AND MAIN SWITCHES.....	<input type="checkbox"/>	<input type="checkbox"/>	<input type="checkbox"/>
15. CHECK THAT THE CONTROLS ARE FUNCTIONING AND ARE UNDAMAGED.....	<input type="checkbox"/>	<input type="checkbox"/>	<input type="checkbox"/>
16. PERFORM A TRIAL RUN WITH THE EMERGENCY STOP PUSHBUTTONS ENGAGED TO VERIFY FUNCTIONALITY.....	<input type="checkbox"/>	<input type="checkbox"/>	<input type="checkbox"/>
17. CHECK THE FUNCTIONALITY OF THE MANUAL RELEASE MECHANISM OF THE BRAKES, CHECKING FOR DAMAGE.....	<input type="checkbox"/>	<input type="checkbox"/>	<input type="checkbox"/>
18. VERIFY THE OPERATION OF THE FINAL TRAVEL STOPS.....	<input type="checkbox"/>	<input type="checkbox"/>	<input type="checkbox"/>
19. ENSURE THAT ALL THE MECHANICAL AND ELECTRICAL SYNCHRONIZED SYSTEMS FUNCTION PROPERLY – BOTH ON THE MACHINE AND ON THE FLOOR LEVELS	<input type="checkbox"/>	<input type="checkbox"/>	<input type="checkbox"/>



Appendix F

General Maintenance (500 hours) Checklist Form (Section 11.2.4)

This page has been left blank for formatting purposes



1895 Robert J. Conlan Blvd NE
 Palm Bay, FL 32905
 Ph. (800) 233-5112
 Fax (321) 768-9517
www.betamaxhoist.com

General Maintenance

500 Hours

MC2000PMB V

Note: If any item is marked FAIL, write comments in the notes section.

	PASS	FAIL	N/A
1. CLEAN THE CABIN FLOORING AND THE AREA AROUND THE MACHINE.....	<input type="checkbox"/>	<input type="checkbox"/>	<input type="checkbox"/>
2. ENSURE THAT ALL WARNING SIGNS ARE LEGIBLE AND IN THE RIGHT PLACE.....	<input type="checkbox"/>	<input type="checkbox"/>	<input type="checkbox"/>
3. ENSURE THAT ALL DOCUMENTS ARE READILY AVAILABLE AND LEGIBLE...	<input type="checkbox"/>	<input type="checkbox"/>	<input type="checkbox"/>
4. CHECK THE OIL LEVEL OF THE GEARBOX.....	<input type="checkbox"/>	<input type="checkbox"/>	<input type="checkbox"/>
5. LUBRICATE THE PINION SHAFT OF THE SAFETY DEVICE THROUGH THE PROPER GREASE NIPPLE.....	<input type="checkbox"/>	<input type="checkbox"/>	<input type="checkbox"/>
6. LUBRICATE THE INDICATED PARTS, PAYING PARTICULAR ATTENTION TO THE RACK.....	<input type="checkbox"/>	<input type="checkbox"/>	<input type="checkbox"/>
7. CHECK THE GREASE LEVEL OF THE AUTOMATIC GREASER.....	<input type="checkbox"/>	<input type="checkbox"/>	<input type="checkbox"/>
8. ENSURE ALL CONNECTIONS OF THE GUIDE ROLLERS TO THE MACHINE'S FRAME ARE CORRECT AND TIGHT.....	<input type="checkbox"/>	<input type="checkbox"/>	<input type="checkbox"/>
9. CHECK THE RACK OF THE MAST AND THE MOTOR PINION; ENSURE THERE IS NO DAMAGE, ALIGNMENT ERRORS, OR DEFECTIVE CONNECTIONS.....	<input type="checkbox"/>	<input type="checkbox"/>	<input type="checkbox"/>
10. ENSURE THAT THE ELECTRIC MOTOR BRAKE FUNCTIONS PROPERLY, THE LOADING UNIT MUST STOP WITHIN THE SET LIMITS WHEN THE BRAKE IS APPLIED.....	<input type="checkbox"/>	<input type="checkbox"/>	<input type="checkbox"/>
11. TIGHTEN ALL BOLTED JOINTS BETWEEN THE COMPONENTS OF THE MAST.	<input type="checkbox"/>	<input type="checkbox"/>	<input type="checkbox"/>
12. TIGHTEN ALL BOLTED JOINTS OF THE WALL ANCHORS.....	<input type="checkbox"/>	<input type="checkbox"/>	<input type="checkbox"/>
13. TIGHTEN CABLE GUIDES AND CHECK FOR MISSING RUBBER KEEPERS.....	<input type="checkbox"/>	<input type="checkbox"/>	<input type="checkbox"/>
14. CHECK EMERGENCY STOP PUSHBUTTONS AND MAIN SWITCHES.....	<input type="checkbox"/>	<input type="checkbox"/>	<input type="checkbox"/>
15. CHECK THAT THE CONTROLS ARE FUNCTIONING AND ARE UNDAMAGED.....	<input type="checkbox"/>	<input type="checkbox"/>	<input type="checkbox"/>
16. PERFORM A TRIAL RUN WITH THE EMERGENCY STOP PUSHBUTTONS ENGAGED TO VERIFY FUNCTIONALITY.....	<input type="checkbox"/>	<input type="checkbox"/>	<input type="checkbox"/>
17. CHECK THE FUNCTIONALITY OF THE MANUAL RELEASE MECHANISM OF THE BRAKES, CHECKING FOR DAMAGE.....	<input type="checkbox"/>	<input type="checkbox"/>	<input type="checkbox"/>
18. VERIFY THE OPERATION OF THE FINAL TRAVEL STOPS.....	<input type="checkbox"/>	<input type="checkbox"/>	<input type="checkbox"/>
19. ENSURE THAT ALL THE MECHANICAL AND ELECTRICAL SYNCHRONIZED SYSTEMS FUNCTION PROPERLY – BOTH ON THE MACHINE AND ON THE FLOOR LEVELS	<input type="checkbox"/>	<input type="checkbox"/>	<input type="checkbox"/>

COMPANY: _____

JOBSITE ADDRESS:

SERIAL NUMBER: _____

YEAR OF MANUFACTURE: _____

TECHNICIAN NAME: _____ **DATE:** _____

TECHNICIAN SIGNATURE: _____

Appendix G

Overweight Sensor System Calibration Procedure (Section 11.3.7)

This page has been left blank for formatting purposes



1895 Robert J. Conlan Blvd, Palm Bay, FL 32905

Phone: 1-800-233-5112

Fax: 1-321-768-9517

www.betamaxhoist.com

support@betamax.zendesk.co

OVERLOAD CONTROL

Type

77

INSTALLATION, USE AND MAINTENANCE HANDBOOK

THIS MANUAL IS AN INTEGRAL PART OF THE DEVICE

- TRANSLATION OF THE ORIGINAL INSTRUCTIONS -

IMPORTANT WARNING!

Carefully read this manual before any installation or calibration.



Descriptions and photos are only to be considered as pure illustrations that could also not correspond to the updated and revised changes made on the product. According to non-stop technological innovations, BetaMax, Inc. reserves the right to make any modifications aimed at improving the product without any notice.

INTRODUCTION

The instruction and maintenance manual is an integral part of the overload control system, and has been issued to advise and inform the operating staff.

This manual is addressed to:

- the staff assembling and dismantling the machine;
- the staff executing the maintenance of the machine;
- the staff repairing the machine;
- the staff making any changes on the machine.

Before any operation, carefully read this manual and any notice, particularly those concerning safety.

BetaMax Hoist declines all responsibility for possible damages caused to the machine, to people, animals and to things, due to:

- *modifications or repairs on the overload control or on the machine without MABER® authorization;*
- *misuse of the device;*
- *non-compliance with the instructions as per this manual;*
- *use of non original MABER® spare-parts;*
- *mistakes in the electrical connections;*
- *anomalies in the power supply.*

The use of the device must comply with the instructions included in this installation, use and maintenance manual, and it is subject to the observance of the existing laws, standards or administrative rules of the country where the machine is installed or used.

IMPORTANT WARNING!



All operations must be performed by trained staff, authorized by MABER®

- Always work wearing any individual protective devices, suitable to the kind of work.
- Avoid to wear necklaces, bracelets or rings that could tangle and cause damages.
- In case of injuries or accidents, immediately contact a doctor.
- The non-compliance with safety warnings may be dangerous for people, the environment, the machine itself, and it may lead to the loss of any right of compensation.

IMPORTANT WARNING !



Pay attention to electrical connections.

Any mistakes in the electrical connections can damage the device.

Check all the electrical connections before powering the device.

Unplug the machine from the main power supply before any modification.

The non-compliance with the above-mentioned precautions can cause serious or mortal injuries.



1895 Robert J. Conlan Blvd, Palm Bay, FL 32905

Phone: 1-800-233-5112

Fax: 1-321-768-9517

www.betamaxhoist.com

support@betamax.zendesk.co

INDEX

1	INSTALLATION	4
1.1	DESCRIPTION OF THE DEVICE	4
1.1.1	TECHNICAL DATA	4
1.1.2	MAIN COMPONENTS	5
1.1.3	COMPONENTS-SPARE PARTS	5
2	INSTALLATION OF THE COMPONENTS	6
2.1.1	OVERLOAD CONTROL PANEL	6
2.1.2	STRAIN GAUGE TRANSDUCERS	6
2.2	ELECTRICAL CONNECTIONS	7
2.2.1	POINT OF CONNECTION ON THE CARD	7
2.2.2	SCHEME TO CONNECT THE BOARD	7
2.2.3	BOARD FEEDING CABLE (CABLE 3G1,5)	8
2.2.4	BOARD CONTACT CABLE (CABLE 5G1,5)	8
2.2.5	CONNECTOR 14P, CONNECTION, FEEDING AND CONTACT	8
2.2.6	CONNECTOR 5P2, TRANSDUCERS CONNECTION	8
3	PROGRAMMING	9
3.1	BUTTONS FUNCTION AND NAVIGATION INTO THE MENU	10
3.1.1	ACCESS TO THE MENU FOR NAVIGATION	10
3.1.2	NAVIGATION IN THE MENUS	10
3.1.3	SETTING OF THE NUMERAL VALUE	10
3.1.4	SELECTION OF PRE-SET VALUE (FIX SELECTION)	10
3.2	MENUS PARAMETERS	11
3.2.1	MENU OF WEIGHING SYSTEM CONSTANT DATA	11
3.2.2	MENU OF EFFECTIVE WEIGHT CALIBRATION (CALIBRATION)	11
3.2.3	MENU FOR ZERO SETTING (AUTO-CALIBRATION)	11
3.2.4	MENU TO SET WEIGHING PARAMETERS	11
3.2.5	MENU FOR ALARMS MANAGEMENT	11
3.3	EFFECTIVE WEIGHT CALIBRATION (CALIBRATION)	12
3.3.1	BOARD FIRST FEEDING	12
3.3.2	PRELIMINARY OPERATIONS	12
3.3.3	SETTING FOR THE WEIGHING PARAMETER	12
3.3.4	WEIGHING SYSTEM CALIBRATION	13
3.4	ZERO SETTING (AUTO CALIBRATION)	14
3.4.1	PRELIMINARY OPERATIONS	14
3.4.2	AUTO-CALIBRATION OF THE WEIGHING SYSTEM	14
4	ALARMS AND STOP OF THE MACHINE	15
4.1	LOAD VISUALIZATION AND ERRORS MESSAGES	15
4.2	STOP RELAY	15
4.3	BUZZER CONTROL RELAY	15
4.4	TABLE OF ALARMS	16
5	INSPECTIONS AND MAINTENANCES	17

1 INSTALLATION

1.1 Description of the device

The overload control device is composed of a MABER 77 card and 2 or plus non amplified strain gauge transducers set under the deck of the machine.

Whenever the alarm threshold exceeds the maximum loading capacity pre-set during the calibration, the overload device emits a continuous sound alarm and stops the machine.

The device is set also with a pre-alarm threshold emitting an intermittent sound when reaching the maximum loading capacity of the machine. In this case the device does not stop the movement of the machine.

The system can be easily adjusted by some buttons and the 4 figures display on the card. The system allows a very simple diagnostic and it is very intuitive. Furthermore, there are only a few components and only one electronic card.



WARNING!

Use only original MABER® spare parts.

The non compliance with these prescriptions can cause the death or serious injury .

1.1.1 Technical Data

Feeding voltage	24 Vac
Maximum contacts capacity	10A in AC1
Working temperature	-20 / +70 °C
Safety grade IP	IP55
Specs of micro-controllers	32 bit ARM Cortex M0
Memory for code software	32 Kbytes FLASH programmable on board by RS232
Memory for data	8 Kbytes
Conformity to Directives	EN61000-6-2, EN61000-6-3 per EMC
	EN 13849-1:2008, EN 13849-2:2008
	EN61010-1 for Electrical Safety
Category according to EN954-1	Cat. 2
Safety Integrity Level according to EN62061	SIL 2



1.1.2 Main components

The system is mainly composed of:

	<p><i>cod. E0300025</i> <u>overload control panel</u></p>
	<p><i>cod. E0300028</i> <u>strain gauge transducers</u></p>
	<p><i>cod. E0300027</i> <u>button loading cells</u> <u>(in some applications they replace the strain gauge transducers)</u></p>

1.1.3 Components-spare parts

Main spare parts:

	<p><i>cod. E0300029</i> <u>electronic card for the overload control device</u></p>
	<p><i>cod. E0300030</i> <u>buzzer of the overload control box</u></p>
	<p><i>cod. E0300031</i> <u>fuse-holder of the overload control box</u></p>

2 Installation of the components

The instructions for the right installation of the overload control components are listed here below:

**WARNING!**

Carefully follow the instructions and take extreme care especially in fixing the strain gauge transducers.
The non respect of these instructions can cause serious injury or the death.

2.1.1 Overload control panel

It is in die-cast aluminium, grey coloured, and it has to be fixed on the loading deck or to an alternative suitable structure (for instance on several models it is installed directly on the electrical panel or on a dedicated plate). A stable installation is necessary, checking the right fixing of the screws.



Example for the box installation.

2.1.2 Strain gauge transducers

Each transducer is made of a metal bar and of a cable out-coming from its central position, sending data to the panel. The two transducers must be fixed to the metal frame under the loading platform, taking into consideration that:

- the transducers assembly has to be made when the machine is unloaded;
- the bearing surface of the transducers must be flat, clean and degreased, and well finished;
- the transducers cables must be installed avoiding any possible damages.

Fix the transducers under the loading platform (in the pre-set \varnothing 10mm drills under the loading platform or, if absent, in the drills to be made according to Maber instructions). The transducers are to be installed on the central part of the frame by M10x40 bolts and self-locking nuts with 2 flat washers at the ends. Add a 2mm flat washer between each transducer and the frame. Bolts must be screwed by a dynamometric wrench set to 6.5 daNm.

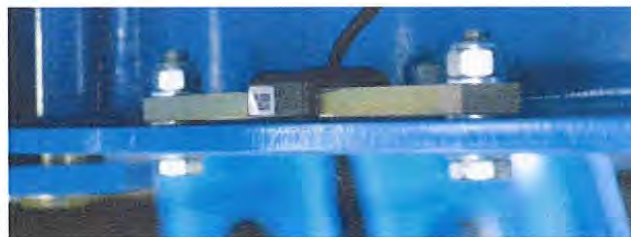

Example for strain gauge installation.

2.2 Electrical connections

The instructions for the electrical connection are listed below:

	<p>WARNING! Carefully follow the instructions, especially when connecting the panel power supply. All connections must be made with the machine switched off unpowered ! The non-compliance with these instructions may cause serious or mortal injuries.</p>
--	--

2.2.1 Point of connection on the card



2.2.2 Scheme to connect the board

Follow the scheme here below and in case refer to the electrical scheme of the machine.

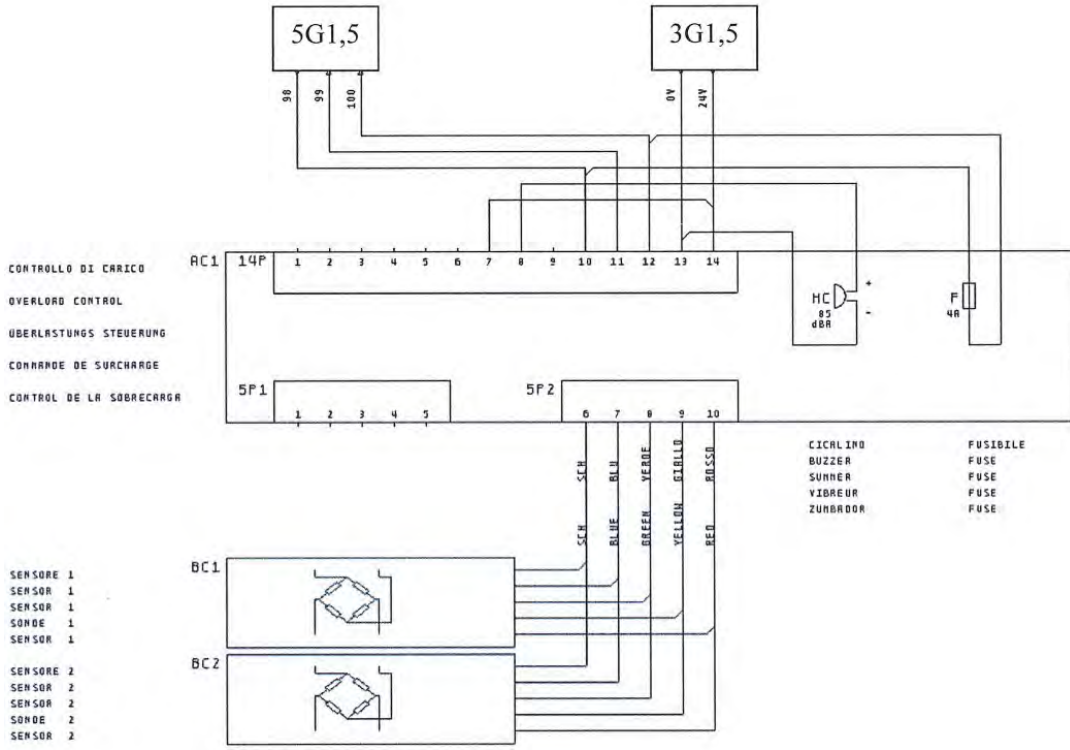

2.2.3 Board Feeding cable (cable 3G1,5)

The panel must be powered by an external source, which has to be electrically bonded. It is necessary to use a 3G 1.5 FROR cable (oil-proof and cut-resistant).

For inside electrical panel connection:

- Connect the wire no. 1 of the cable to a “0” of the auxiliaries feeding (for instance to the “0V” terminal);
- Connect the wire no. 2 of the cable to the “24 Vac” of the auxiliaries feeding (for instance to an “24V” terminal);
- Connect the yellow-green wire to an earth.

For inside electrical board connection:

- Make the connections as illustrated in the above-mentioned scheme

2.2.4 Board contact cable (cable 5G1,5)

The panel has a contact stopping the machine when overloaded. It is necessary to use a 5G 1.5 FROR cable (oil-proof and cut-resistant).

Connect the wires inside the electrical panel in series to the safety circuit:

- the wire no. 1 of the cable in series to the safety circuit (for instance to a “98” terminal);
- the wire no. 2 of the cable in series to the safety circuit (for instance to a “100” terminal);
- the wire no. 3 of the cable to feed the warning light (for instance to a “99” terminal)**
- the wire no. 4 of the cable not used and isolated
- the yellow-green wire to a screw of earth on the electrical panel and on the board.

Connect the inside board wires:

- as illustrated in the above-mentioned scheme

2.2.5 Connector 14P, connection, feeding and contact

Connect 3G1,5 and 5G1,5 :

- Pole 7 = **HC** *buzzer feeding connection (in parallel with pole 14 , 24 Vac);
- Pole 8 = contact to allow **HC** *buzzer functioning ;
- Pole 10 = common pole of the alarm contact (in parallel with a wire of **FC**** fuse-holder
- Pole 11 = pole usually closed of the alarm contact;
- Pole 12 = pole usually open of the alarm contact (in parallel with the other wire of **FC**** fuse-holder
- Pole 13 = earth feeding the card (0V , in parallel with **HC*** buzzer earth)
- Pole 14 = positive feeding card (in parallel with pole 7, 24 Vac)

(* **HC** buzzer is on the cover of the board box.

(**) **FC** fuse-holder is in the lower part of the board. **Warning : once the fuse inserted, the overload control is excluded.**
During the normal working phase, this fuse must be absent.

(***) option: necessary if the electrical panel has a warning light for the “overload”.

2.2.6 Connector 5P2 , transducers connection

The cables of the transducers are connected in parallel on the connector 5P2 of the board card. Make the connections to the connector according to the following instructions:

- Pole 6 = connect the cable **shield** of the 2 transducers;
- Pole 7 = connect the **bleu** wires of the 2 transducers;
- Pole 8 = connect the **green** wires of the 2 transducers;
- Pole 9 = connect the **yellow** wires of the 2 transducers;
- Pole 10 =connect the **red** wires of the 2 transducers;

WARNING

If the weight goes negative while loading the machine, invert the connection of the yellow with the green wires.

The system is also suitable in case of “button loading cells” (up to 4 cells can be connected in parallel) , with the same wires scheme of connection.

3 PROGRAMMING

Before any operation, check the correct installation of the components and power the machine only after this control.



WARNING!

Functioning tests are necessary after each calibration or self-calibration.
The non-compliance with these instructions may cause serious or mortal injuries.

Display and programming buttons

The small checking panel is composed of a 4 digit display with 4 buttons to set the device:

- The buttons are in sequence (1 to 4) starting from the bottom
- The display shows the effective weight loaded on the machine (in kg)
- The correct value for the weight is shown after the calibration

D1 = Display

T1 = Control button



T2 = Control button



T3 = Control button



T4 = Control button



D1

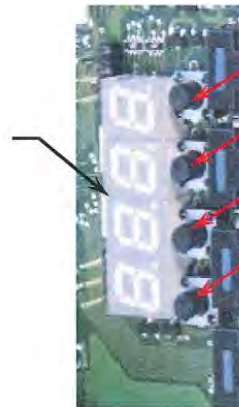

T4

T3

T2

T1



WARNING!

Pay attention during the setting to temperatures higher than 50°C close to the buttons.





WARNING!

Pay attention during the setting to card voltage, in any case not dangerous being under 24 Vac.



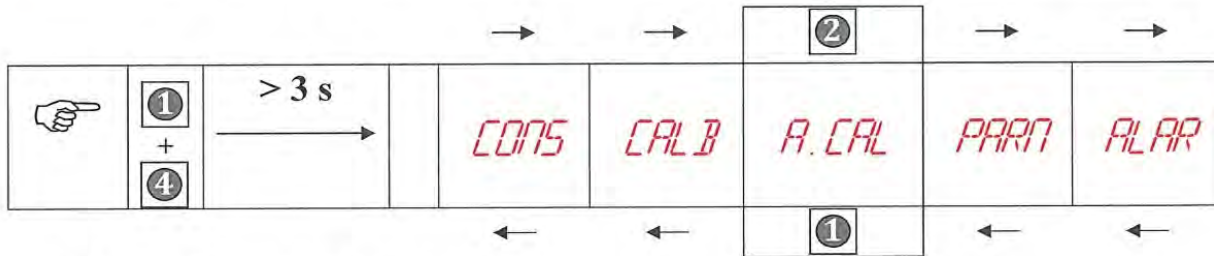

3.1 Buttons function and navigation into the menu

3.1.1 Access to the menu for navigation





DISPLAY	BUTTON	Function
	 T1	Access to the main menu: keep simultaneously pressed for approx. 3 seconds T1 and T4 . Release the buttons only when the display visualizes: CONS .
	 T4	







3.1.2 Navigation in the menus

DISPLAY	button	Function
	 T1	Former entry
	 T2	Next entry
	 T3	Exit from the menu/exit
	 T4	Enter the menu/ enter to modify the selected parameter

3.1.3 Setting of the numeral value

DISPLAY	BUTTON	Function
	 T1	Increase selected number
	 T2	Decrease selected number
	 T3	Go to select the right figure of the number (the selected value blinks)
	 T4	Confirm and save the value

3.1.4 Selection of pre-set value (fix selection)

DISPLAY	BUTTON	Function
	 T1	Former value
	 T2	Next value
	 T3	--
	 T4	Confirm and save the value

3.2 *Menus parameters*

3.2.1 *Menu of weighing system constant data*

menu	Parameters	Description	Default
CONS	CAP	CAPACITY of the system (kg)	5000
	SENS	LOAD CELLS SENSITIVITY (mV/V)	2.000
	JDW	SPLIT VALUE (kg) automatically modified according to CAP.	2

!warning! after the change of the parameters as per this menu, is compulsory to calibrate again the weight.

3.2.2 *Menu of effective weight calibration (calibration)*

menu	Parameters	Description	Default
CALB	CAL.2	CALIBRATION OF THE ZERO (TARE WEIGHT)	*
	CAL.5	CALIBRATION OF THE MAX. VALUE (CAPACITY)	*

* for the correct calibration procedure, please refer to the dedicated chapter

3.2.3 *Menu for zero setting (auto-calibration)*

menu	Parameters	Description	Default
A.CAL	CAL.2	CALIBRATION OF THE ZERO (TARE WEIGHT)	*

* for the correct auto-calibration procedure, please refer to the dedicated chapter

3.2.4 *Menu to set weighing parameters*

menu	Parameters	Description	Default
PARN	FILT	DIGITAL FILTER ON THE WEIGHT	5
	IN.0	AUTO-ZERO AT STARTING	0000
	TR.0	PURSUIT ZERO	0
	SIG	VISUALIZATION OF THE TRANSDUCERS SIGNAL (mV/V)	*

* effective value in case of diagnostics changing according to the load

3.2.5 *Menu for alarms management*

menu	Parameters	Description	Default
ALAR	PREA	PRE THRESHOLD ALERT (% on CAP parameter)	010.0
	PRE.5	SIGNAL FOR THE PRE THRESHOLD ALERT	NEG
	BLOC	BLOCK THRESHOLD (% on CAP parameter)	000.0
	BLO.5	SIGNAL FOR THE BLOCK THRESHOLD	POS
	S.PES	UNDERWEIGHT THRESHOLD (in % on CAP parameter)	100.0



WARNING! Do not change the default parameters if not indicated in the procedure. In case of any changes, set the parameters back to the values as in the above-mentioned tables.

3.3 Effective weight calibration (calibration)

Proceed with the calibration only after checking the correct installation of all the components. The calibration must be performed with open front cover of the board, avoiding the contact between any part in voltage with any metal mass.



WARNING!

Never cut off the feeding of the board during the calibration to avoid any data loss (except when expressly requested).

3.3.1 Board First Feeding

For the first feeding:

1. Turn the machine ON.
2. Check the board is emitting an intermittent sound.
3. Wait for approx 5 seconds after the sound .
4. Check if the display is visualizing a numerical value (weight)
5. Set the weighing system capacity (CAP) as hereunder illustrated

If the buzzer continues to ring, check the display with detail on the alarm. If necessary, enter the setting menu (all the alarms are deactivated) and check the parameters.

3.3.2 Preliminary operations

It is necessary to:

1. check if the machine is not laying on the lower shock absorbers;
2. totally unload the machine and close all the ramps/doors;
3. dispose of a load equal to the lifting capacity of the machine (ready for loading)

3.3.3 Setting for the Capacity of system parameter

This parameter is set during the first installation of the device on the machine (or in case of replacement of the device). Each parameters modification requires a complete calibration of the weighing system. Refer to the following instructions and tables:

	DISPLAY		
1	1234	① + ④	Access to the main menu: Push simultaneously for approx 3 seconds T1 and T4 buttons. Release the buttons only when the display visualizes CONS .
2	CONS	④	The display visualizes CONS . To enter CONS menu – press T4 button.
3	CAP	④	The display shows CAP parameter. Enter into the parameter pressing T4 button.
4	5000	① ② ③	The display shows the value for CAP parameter: set the capacity of the machine in kg (for instance 2000 kg). To set the parameter, use the buttons as illustrated at chapter 3.1.3 .
5	2000	④	When the display visualizes the machine capacity (for instance 2000 kg) confirm the value pushing T4 button.
6	CAP	③	The display visualizes CAP parameter Exit by pushing T3 button.
7	CONS		The display visualizes CONS Calibrate the weighing system (refer to next chapter)

3.3.4 Weighing system calibration

Follow the below-listed instruction and tables and if inside the main menu, jump point 1.



	DISPLAY		
1	1234	① + ④	Access to the main menu: Push simultaneously for approx 3 seconds T1 and T4 buttons. Release the buttons only when the display visualizes CONS .
2	CONS	②	The display visualizes CONS Go to the next menu by T2 button.
3	CAL.B	④	The display visualizes CALB Enter the menu pushing T4 button.
4	CAL.2	①	The display visualizes CAL.Z alternating a 4 figures number. Memorize the tare of the machine pushing T1 button: the displayed value is re-set.
5	CAL.5	//	The display visualizes CAL.S alternating a value nearly equal to 0000 Load the machine with the <u>maximum lifting capacity</u> (for instance 2000 kg) uniformly spread on the deck (refer to the "Maximum capacity" indicated in the ID plate of the machine); Close all the ramps/doors; Check the loading deck keep still;
6	CAL.5	②	The display visualizes CAL.S alternating a 4 figures number much greater than zero. Press T2 to memorize the weight loaded into the machine.
7	2000	④	The display visualizes the machine maximum capacity as set in CAP parameter. If CAP is wrong, modify it and repeat the procedure. Confirm the loaded weight pushing T4 button.
8	2000	④	The display visualizes the machine maximum capacity as set in CAP parameters. Confirm all the procedure by pressing T4 button.
9	CAL.B	③	The display visualizes CALB Exit the main menu pushing T3 button.
10	2000	//	The display visualizes the effective weight loaded inside the machine.

At this point the control board is calibrated. Ensure that:

1. once the machine loaded with its maximum loading capacity, the device emits a continuous sound and stops the machine;
2. decreasing the load, the machine emits an intermittent sound (not continuous) and it can run.
3. the visualized load value decreases while removing the load from the deck and that it reaches approx 0000 when the machine is empty.

If not, check all the parameters of the device and repeat the procedure from point 1.

In case of positive result after the tests, close the board cover and strongly tighten the cover closing screws .

	In case of power supply cut, repeat the calibration procedure from point 1
	In case of errors or incorrect functioning of the board, repeat the procedure from point 1 and if necessary, refer to chapters No. 4 and 5.
	Pay extreme attention to uniformly spread the load on the deck and to the maximum loading capacity of the machine where the overload control device has to be installed.

3.4 ZERO setting (auto calibration)

The re-calibration of the system is possible automatically without repeating the calibration.

The auto-calibration updates only the zero.

	WARNING ! The auto-calibration procedure can be performed only after the setting of the system!
---	---

The auto-calibration allows a quick calibration of the board and it is necessary when the deck of the machine has received some hits (for instance during the transport or the dismantling).









The auto-calibration must be performed having the board front cover open and avoiding any contact between the parts in voltage and any metal mass.

3.4.1 Preliminary operations

1. Check that the machine is not laying on the base shock absorbers;
2. Totally unload the machine and close all the ramps/doors;

3.4.2 Auto-calibration of the weighing system

Follow the following instruction and tables and if already inside the main menu, jump point 1.

	DISPLAY		
1	1234	 + 	Access to the main menu: Push simultaneously for approx 3 seconds T1 and T4 buttons. Release the buttons only when the display visualizes CONS
2	CONS		The display visualizes CONS Go to the next menu by T2 button.
3	CAL B		The display visualizes CALB Enter the menu pushing T2 button.
3	A.CAL		The display visualizes A.CAL Enter the menu pushing T4 button.
4	CAL.Z		The display visualizes CAL.Z alternating it to a 4 figures value. Memorize the tare of the machine pushing T1 button, the displayed value is re-set.
5	CAL.Z		The display visualizes CAL.Z alternating it to a numerical value close to 0000 Confirm the whole procedure with T4 button.
9	A.CAL		The display visualizes A.CAL Exit the main menu pushing T3 button.
10	0000	//	The display is now visualizing 0000 (machine completely empty)

At this point the control board is calibrated. Ensure that:

1. once the machine loaded with the maximum loading capacity, the device emits a continuous sound and stops the machine;
2. decreasing the load, the machine emits an intermittent sound (not continuous) and it can run.
3. the visualized value on the display decreases while removing the weight from the deck and that it reaches approx 0000 when the machine is empty.

If not, check all the parameters of the device and repeat the procedure from point 1.

In case of positive result after the tests, close the cover of the board and strongly tighten the cover closing screws .

	In case of errors or incorrect functioning of the board, repeat the procedure from point 1 and, if necessary, refer to chapters No. 4 and 5 and make a fully calibration .
---	--

	Pay extreme attention to uniformly spread the load on the loading deck and to the maximum loading capacity of the machine where the overload control device has to be installed.
---	--

4 ALARMS AND STOP OF THE MACHINE

4.1 LOAD VISUALIZATION AND ERRORS MESSAGES

The display normally visualizes the weight as detected by the transducers or the messages of errors. During the setup and the programming it visualizes the information, values and messages regarding the related procedures.

4.2 STOP RELAY

During the normal functioning of the device, the stop relay contacts are closed; and when it is in alarm, they are open.

Here under there are the situations of alarm leading to the opening of the contacts on the stop relay:

- Negative underflow of the underweight threshold .
- Overcoming of the stop threshold.
- Alarm (refer to the alarm table).

4.3 BUZZER CONTROL RELAY

The contacts are open in case of normal functioning without any alarm (thus with no sound of alarm); in condition of alarm the contacts are closed for a period of time that changes according to the kind of alarm.

The situation of alarm leading to the closure of the contacts relay are the following ones:

- **Negative underflow of the underweight threshold.** The contacts relay close for 1 second each 4 seconds (sound of alarm with slow intermittence).
- **Overcoming of the pre-alarm threshold .** The contacts relay close for 1 second each 2 seconds (sound of alarm with quick intermittence).
- **Overcoming of the stop threshold.** The contacts relay close for all the duration of this situation (continuous sound of alarm).
- **General situation of alarm .** The contacts relay close for 1 second each 4 seconds (sound of alarm with slow intermittence).

4.4 TABLE OF ALARMS

In case of a sound having slow intermittence (sound each 4 seconds) open the cover of the board and check the displayed message . For details, refer to the following table:

DESCRIPTION OF THE ALARM	VISUALIZED CODE/MESSAGE	
NO CONNECTION OF THE LOAD CELL. REMEDY : Check the correct insertion of the transducers 5 poles connector	<i>N.CON</i>	
WRONG CONNECTION OF THE LOAD CELL. REMEDY: wrong transducers wires connection on the 5 poles connector. Check the connection.	<i>E.CON.</i>	
LOAD CELLS OUTSIDE NEGATIVE RANGE . The load cells signal is lower than $-3.9mV/V$, probably because of a wrong connection. REMEDY: Check the connections or replace the transducers, if necessary	<i>LO.SI</i>	
LOAD CELLS OUT OF POSITIVE RANGE. The load cells signal is higher than $+3.9mV/V$, probably because of a wrong connection. REMEDY: Check the connections or replace the transducers, if necessary	<i>HI.SI</i>	
INSIDE FAILURE : HARDWARE. Inner voltage levels out of normal working limits or "watchdog" intervention. REMEDY: Replace the card .	No message	
INSIDE FAILURE: NO SIGNAL FROM LOAD CELLS. In this case there is a fault on the data acquisition system. REMEDY: Replace the card.	<i>E.ADC</i>	
INSIDE FAILURE: MEMORY SETUP PARAMETERS The checking system of the memory data integrity has detected an error. REMEDY: Replace the card.	<i>E.MEM</i>	
LOAD CALIBRATION NOT CARRIED OUT. The load calibration has not been completed REMEDY: Turn "off " and "on" again the controller and follow the calibration procedure .	<i>N.CAL.</i>	
UNDERWEIGHT. The detected load value is lower than the set underweight threshold. REMEDY: Check the correct installation of the transducers and that their yellow and green wires are not connected in reverse way on the 5 poles connector. Check the VALUE of the parameter S.PES. in the menu ALAR, and make any necessary rectification.	<i>U.PES</i>	

WARNING: The alarms with  symbol : stay active also after solving the situation that has generated them. To re-arm the correct functioning first remove the feeding from the board and later power and switch it on again.



1895 Robert J. Conlan Blvd, Palm Bay, FL 32905

Phone: 1-800-233-5112

Fax: 1-321-768-9517

www.betamaxhoist.com

support@betamax.zendesk.co

5 INSPECTIONS AND MAINTENANCES

A correctly installed system does not need of any particular maintenances during its operating life. The list of the necessary operations/tests to check the functioning of the system are listed here under . Being a safety device, the lack of these tests may cause a risk for the operator.

Controls after the installation:

The first assembly of the system requires the control of:

- correct voltage for the feeding.
- correct closure of the box and of the tightening of the press-cables.
- the switch off of the device by the main switch.
- the correct electrical connection.

Control of the transducers:

In case of alarm regarding the transducers functioning, make the diagnostic of each transducer joining it to the load cell. Connect a sensor at a time and identify the one with the anomaly thanks to the visualized message on the card display.

Routine Maintenance

Perform the following checks periodically:

- Visual control of the transducers, board, and connecting cables integrity.
- Control of the buzzer functioning when the machine is powered.
- Control of the system correct functioning, while simulating the overload situation, stopping the machine.

Special Maintenance

Special maintenance operations must be carried out by skilled staff. In any case, we suggest contacting BetaMax or their distributor. All that is not listed within the routine maintenance and within the installation instructions has to be considered as special maintenance.