

1

10-995A STANDARD I-BEAM TROLLEY QUICK START GUIDE

WARNING - This guide is not a substitute for fully reading and understanding the portable hoist manual.

Items required;

- 1) Standard portable hoist.
Gemini, New Yorker, or Leo series.
- 2) 1T Standard I-Beam trolley top
Part number 60-25.
 - I-beam trolley top (1)
 - Guide plate (1)
 - 1/2 - 13 bolt x 4" (1)
 - 1/2 - 13 bolt x 4-1/2" (2)
 - 1/2 nylock nut (3)

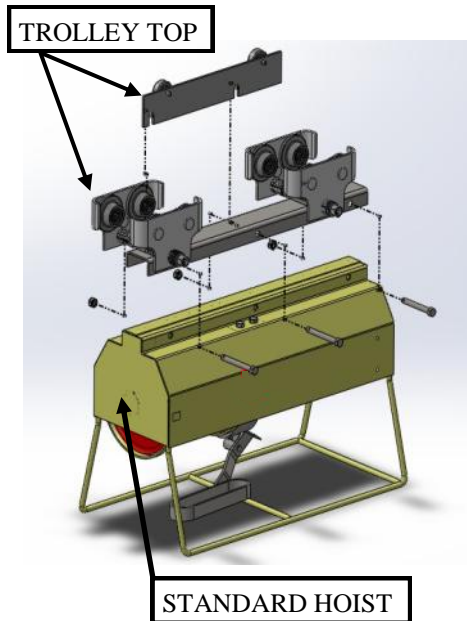

2

INSTALL TROLLEY TOP.

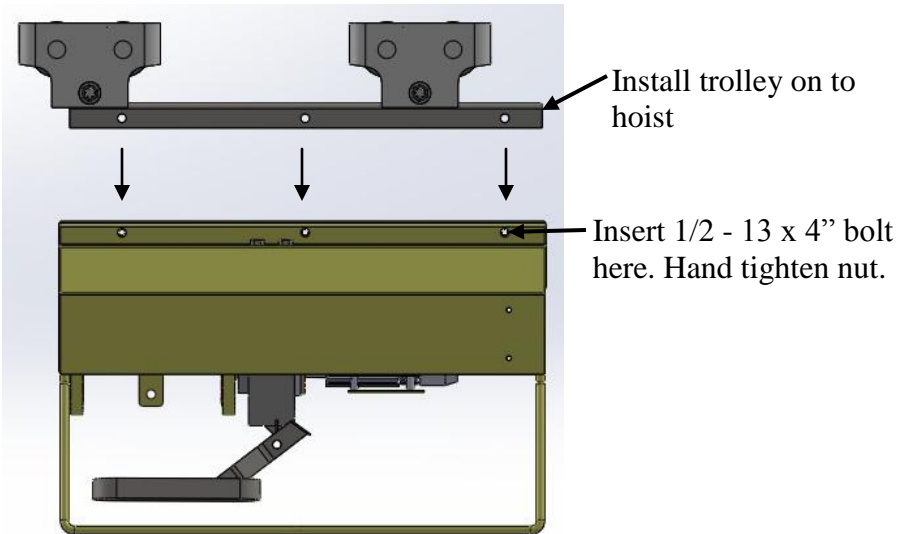

3

INSTALL GUIDE PLATE

Maneuver guide plate down onto trolley so that the slots line up with the holes on the far side of the top.

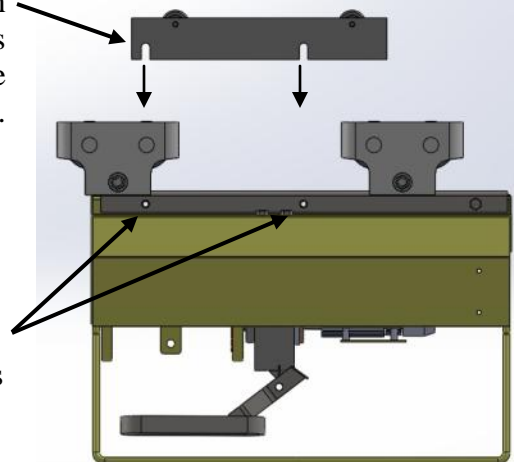

Install the remaining bolts 1/2 - 13 x 4-1/2 and nuts. Snug bolts to keep plate in place.

4

FINAL ASSEMBLY

- VIEW FROM THE TOP

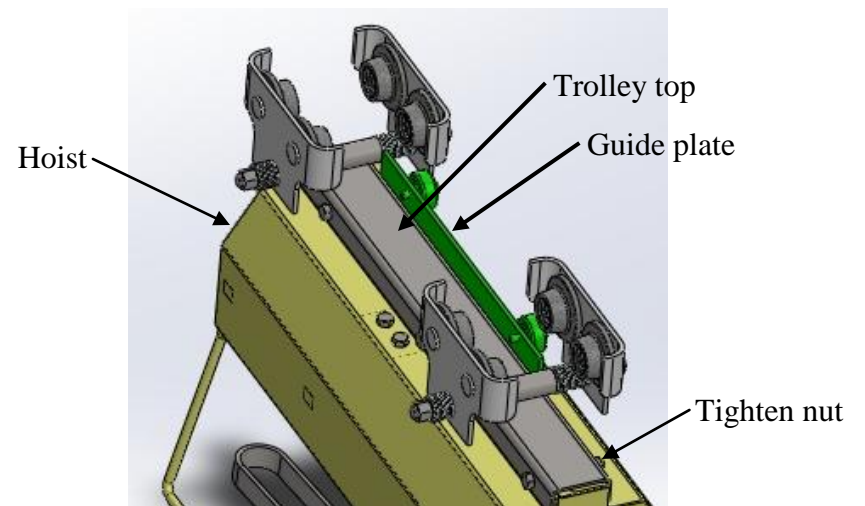

5 INSTALLATION OF HOIST ON TO BEAM

***** NOTE: I-Beams that support the hoist are the sole responsibility of the user. Their design, supply, installation, and use are all by others. BetaMax does not recommend or consult on any beams. This is performed by an engineer of record on the jobsite or an independent engineer. This is to assure that the installation for the project is stable and structurally sound. Be sure your installation is safe by confirming it is designed and installed correctly.**

BetaMax is responsible for the function of the hoist only. BetaMax is not responsible for any installation.

7 I-BEAM INSTALLATION

NOTE: Beam stops are critical to the safe use of the hoist and shall always be used. Stops are part of the beam assembly and are supplied with the beam

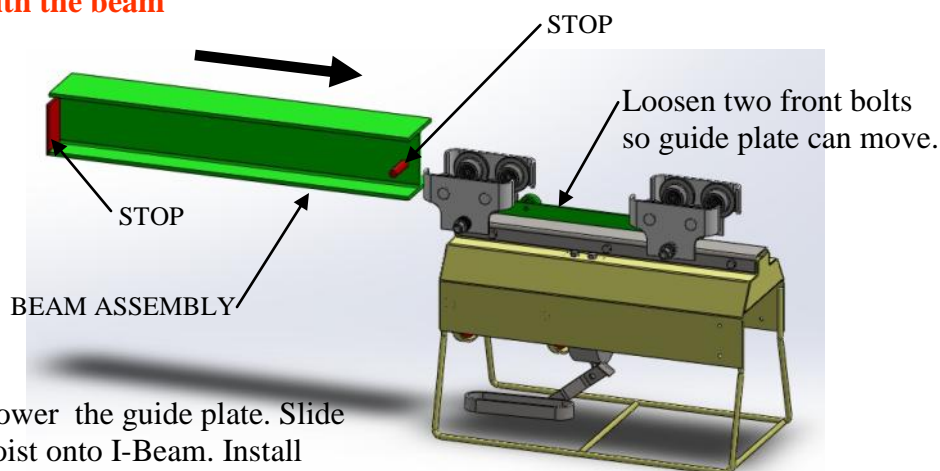

Lower the guide plate. Slide hoist onto I-Beam. Install removable stop to secure hoist on I-Beam.

6 TROLLEY ADJUSTMENT

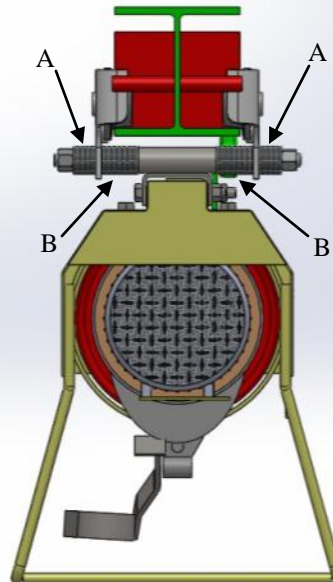

Adjust trolleys so the outside to outside dimension of the trolley is 2" larger than the flange of the beam. Do this by moving the number of washers you have on the inside and outside of the trolley. Be sure that the number of washers are equal on either side of the hoist (inside = inside and outside = outside). Be sure that all washers are put back on to the threaded rod and put back on the side they came from.

"A" number of washers are equal. Outside of trolley

"B" number of washers are equal. Inside of trolley

8 ADJUST GUIDE WHEEL

Push guide plate up so that rollers just touch beam. Tighten the two front bolts to secure guide plate.

Recheck that all bolts are tight.

