



Control your work flow, schedule, and budget with the fastest, most consistent material delivery on the market with Beta Max™ high speed hoists

faster. safer. smarter.

NEW YORKER

H 350ft | Capacity: 600lbs

KEY FEATURES

- Perfect for high reach, medium duty projects
- Confined and hard to reach spaces made easy with a portable hoist
- Increased jobsite safety and efficient alternative to rope & pulley systems, cranes, and forklifts
- Optional Scaff-Trac Mounting System provides a standardized and complete lifting solution engineered for easy installation every time
- Easy cable replacement (Beta Max™ provides clamps and crimp)
- Flexible I-Beam Mounting Option works with and configures to each unique job-site
- Long lasting performance with minimal maintenance required



SAFETY FEATURES

- Water tight connectors
- Failsafe brake holds the load securely when not lifting or lowering--loads are powered up and down, no free-falling or slipping
- Non-rotating cable helps keep loads from spinning
- Upper-limit Switch Assembly stops the hoist instantly when activated
- Sturdy electrical controller equipped with thermal overload sensing device

INDUSTRIES SERVED

- Scaffolding
- Demolition
- Masonry
- Restoration
- Stucco
- Construction



Contact Beta Max today for local dealer information, to discuss your project, or get a quote.
www.BetamaxHoist.com **(800) 644-6478**

* All Beta Max Hoist Systems meet or exceed ANSI & OSHA specifications. This information is intended to be informative only, and does not constitute a representation or warranty with regard to Beta Max Hoists or any products or services provided. Prices and information are subject to change. Some or all of the renderings in these materials may vary from the actual hoists.

Rev. 05-2016

SPECIFICATIONS

Set Up	Single Line
Lift Capacity	600 lbs
Lift Speed	80 fpm
Lift Height	350'
A/C Power	220v, 1Φ, 1.5HP
Horsepower	1.5HP
Mounting Options	Fixed I-Beam, I-Beam Trolley, Mac-Trac, Scaff-Trac, Trestle Monorail

MOUNTING OPTIONS

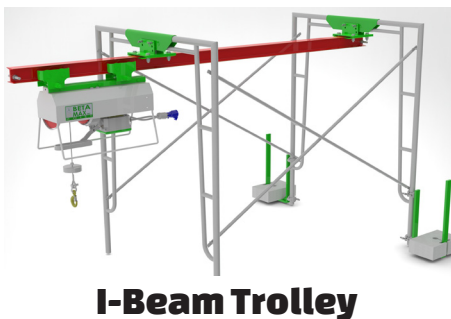
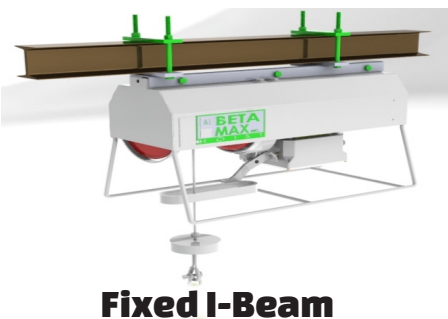
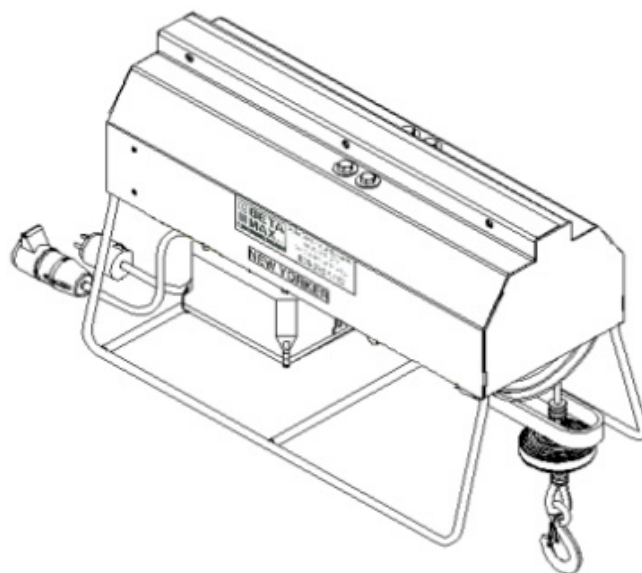

ACCESSORIES

- Brick Fork
- Block Fork
- Scaffold Frame Fork
- Equipment Basket
- Dumpster Bucket
- Spreader Bar
- Mud Tub
- Counterweight Clamp Assembly
- Remote Control Extension
- Power Cord Extension
- Wireless Dual Control Package
- Booster Transformer

**Contact Beta Max today for local dealer information,
to discuss your project, or get a quote.**